

WeatherBond™ Pro ROOFING SYSTEM

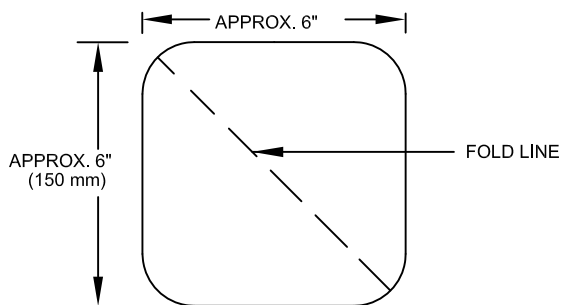

CUT A SECTION OF WEATHERBOND PRO NON-REINFORCED MEMBRANE WITH ROUNDED CORNERS OR USE INSIDE/OUTSIDE CORNER; FOLD ALONG LINE AS INDICATED.

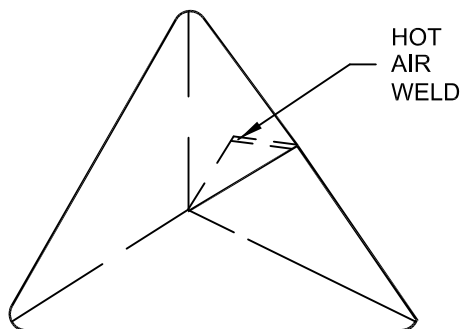
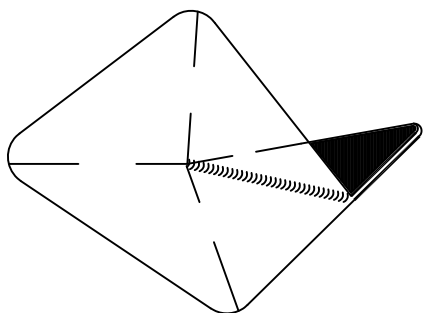
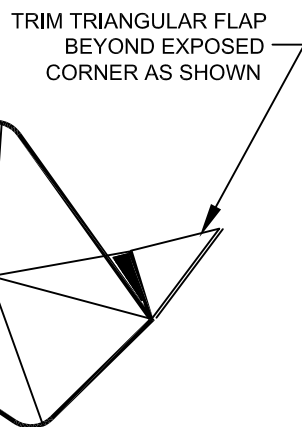
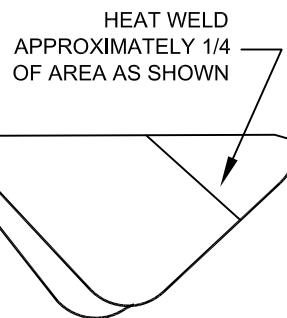
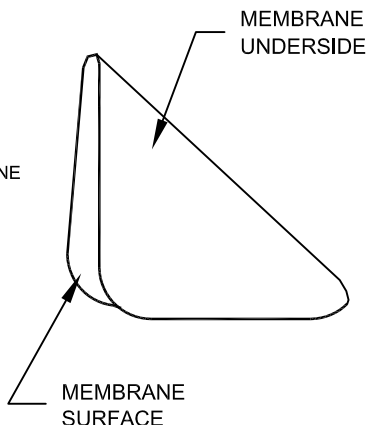

POSITION AND HEAT WELD CORNER IN PLACE AS SHOWN

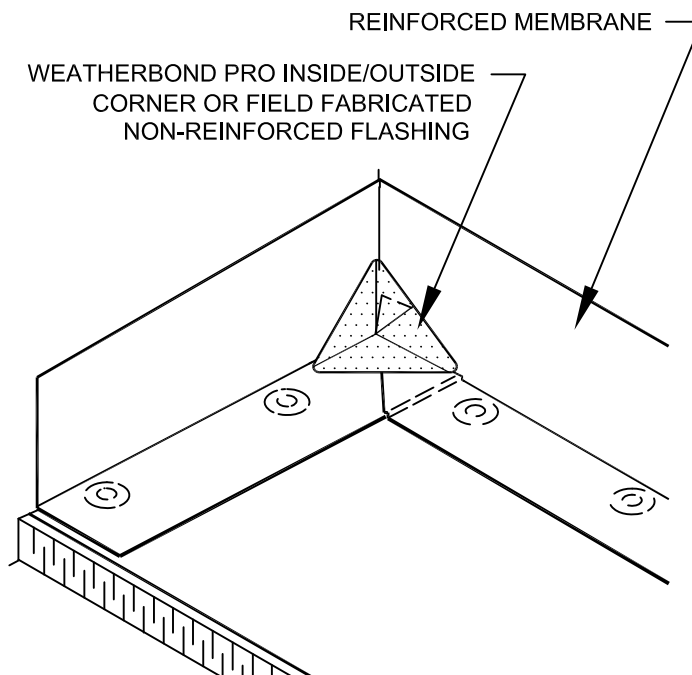

WBPC-15.2
INSIDE CORNER FABRICATION

WEATHERBOND™
© 2007 WEATHERBOND