



**WeatherBond EPDM Roofing Systems
Fully Adhered and Mechanically Attached**

TABLE OF CONTENTS

January 2024

Part I-General	Page
1.01 Description	3
1.02 General Design Considerations	3
1.03 Quality Assurance	5
1.04 System Recommendations	5
Tables	
TABLE I – Mechanically Attached Roofing Systems – Membrane Fastening Criteria – Steel/Concrete Decks	5
TABLE II – Mechanically Attached Roofing Systems – Membrane Fastening Criteria – Wood Decks.....	6
TABLE III- Re-roofing Substrate Criteria	6
TABLE IV –Fully Adhered Roofing Systems–Underlayment/Fastening Density.....	7
1.05 Product Delivery, Storage and Handling	7
Part II – Products	
2.01 Membrane.....	8
2.02 Insulation/Underlayments.....	11
2.03 Related Materials.....	16
2.04 Fastening Components	17
2.05 Insulation Securement Adhesive.....	19
2.06 Vapor/Air Barrier.....	20
2.07 Edgings/Terminations	20
2.08 Roof Walkways	21
2.09 Other WeatherBond Accessories.....	21
Part III – Execution – Fully Adhered and Mechanically Attached	
3.01 General.....	21
3.02 Roof Deck/Substrate Criteria.....	21
3.03 Insulation/Underlayments.....	24
3.04 Insulation Attachment	24
3.05 Membrane Placement and Securement	26
3.06 Flashing	32
3.07 Roof Walkways.....	33
3.08 Daily Seal.....	33
3.09 Clean Up.....	33
Note: In addition to information listed in this section please reference Spec Supplement and Design Reference Sections for other pertinent information.	
Installation Details.....	35

This page intentionally blank



WeatherBond EPDM Roofing Systems Fully Adhered and Mechanically Attached

January 2024

This section is to serve as a guide regarding the design and installation of WeatherBond's Fully Adhered and Mechanically Attached EPDM Roofing Systems. Additional information essential for the design and installation of the roof system mentioned herein are also included in the Design Reference Section and also listed in the form of a Specification Supplement.

PART I – GENERAL

1.01 Description

- A. **The Fully Adhered Roofing System** incorporates **WeatherBond (black) 60- or 90- mil thick non-reinforced or WeatherBond (gray) 60 mil thick non-reinforced or WeatherBond (white) 60-or 90mil thick non-reinforced or WeatherBond(white) 60-mil thick reinforced or 45-, 60- or 75-mil WeatherBond** reinforced EPDM membrane.

An acceptable insulation is mechanically attached to the roof deck or Fully Adhered with WeatherBond supplied urethane-based insulation adhesive or hot asphalt and the EPDM membrane is Fully Adhered to the insulation with WeatherBond's EPDM Bonding Adhesive (WeatherBond's LC-60 Bonding Adhesive, x-23 Low-VOC Bonding Adhesive, CAV-GRIP III or Aqua Base 120 Water Based Bonding Adhesive). Adjoining sheets of EPDM membrane are spliced together using 3" or 6" wide P&S Seam Tape and Primer or factory-applied P&S Seam Tape (WeatherBond EPDM w/ Pre-applied Seam Tape) and Primer. There are no maximum slope restrictions for the application of this roofing system.

Note: When non-reinforced EPDM membrane is used, WeatherBond recommends a minimum of 60-mil thick material. WeatherBond 45-mil non-reinforced EPDM may be utilized when specified or required by the owner or owner's representative.

- B. **The Mechanically Attached Roofing System** incorporates **reinforced** (black or white) EPDM membrane. An acceptable insulation is Mechanically Attached to the roof deck and, depending on project criteria; the reinforced membrane is Mechanically Attached with the appropriate WeatherBond Fastener and 2" or 2-3/8" diameter Fastening Plates (Polymer Plates required over steel deck) or Fastening Bars at 6" minimum to 12" maximum along the center of the membrane splice.

Adjoining sheets of EPDM membrane are spliced together using factory-applied P&S Seam Tape and Primer or P&S Seam Tape and Primer. Field membrane sheets are either 8' or 10' wide depending upon wind load requirements, building height and type of roof deck. At the roof perimeter, a heavier fastening density is required utilizing 5' wide sheets or 6.5' wide sheets or 9" wide Peel & Stick RPS (Reinforced Perimeter Strip). The maximum roof slope for this roofing system is 18' in one horizontal foot.

1.02 General Design Considerations

- A. Petroleum based products; certain chemicals and waste products (i.e., grease, oil, animal fats, etc.) are not compatible with these roofing systems.
- B. It is the responsibility of the building owner to review local, state and regional codes to determine their impact on the specified WeatherBond Roofing System.
- C. It is the responsibility of the building owner or his/her designated representative to verify structural load limitation.
- D. Coordination between various trades is essential to avoid unnecessary rooftop traffic over completed sections of the roof and to prevent subsequent damage to the membrane roofing system.

E. Concentrated loads from rooftop equipment may cause deformation of insulation/underlayment and possible damage to the membrane if proper protection is not provided. A protection course or sleepers must be specified.

F. Drainage

1. Drainage must be evaluated by the Specifier in accordance with all applicable codes. Slope may be provided by tapering the structure or through the use of tapered insulation; a sufficient number of roof drains should also be specified and properly located to allow for positive drainage. Significant ponding that could remain after 48 hours should be eliminated with the addition of auxiliary drains in low areas where ponding is anticipated.

WeatherBond specifically disclaims responsibility for the design and selection of an adequate drainage system and drain accessories. Selection must be made by the building owner or the owner's design professional.

2. Small incidental areas of ponded water will not impact the performance of this roofing system; however in accordance with industry standards, the roofing assembly **should be designed to prevent ponding** of water on the roof for prolonged periods (longer than 48 hours). Good roofing practice dictates proper drainage to prevent possible excessive live loads and, in the event of a roof leak, to minimize potential interior damage to the roofing assembly and to the interior of the building.
3. **Tapered edge strips, crickets or saddles** are recommended where periodic ponding of water may occur. When the slope of the taper exceeds 2" to one horizontal foot additional membrane securement at the base of the tapered edge strip, cricket or saddle will be required.
4. On **WeatherBond White EPDM Fully Adhered Roofing Systems**, a slope greater than 1/8" per horizontal foot is recommended to serve the long-term aesthetics.

G. On new construction projects, especially in cold climate regions, moisture generated due to the construction process could adversely impact various components within the roofing assembly if not addressed.

H. Vapor Retarders

1. WeatherBond does not require a vapor retarder for the protection of the membrane; however, it should be considered by the specifier for the protection of the roofing assembly (i.e. primarily insulation, underlayment and adhesives). The following criteria should be considered by the specifier:
2. Use of a vapor retarder to protect insulation and reduce moisture accumulation within an insulated roofing assembly, should be investigated by the specifier.
3. In the generally temperate climate of the United States, during the winter months, water vapor flows upward from a heated, more humid interior toward a colder, drier exterior. Vapor retarders are more commonly required in northern climates than in southern regions, where downward vapor pressure may be expected and the roofing membrane itself becomes the vapor retarder.

I. On structural concrete decks, when a vapor retarder is not used, gaps in the deck along the perimeter and around penetrations must be sealed along with vertical joints between tilt-up panels, if present, to prevent infiltration of hot humid air and possible moisture contamination resulting from condensation. This is specifically important when adhesive is used to attach the roof insulation.

NOTE: If left unaddressed, collected moisture could weaken insulation boards and facers resulting in a blow-off or increase the probability of mold growth.

J. **Retrofit- Recover Projects** (when the existing roofing material is left in place)

1. The removal of existing wet insulation and membrane must be specified. The Specifier shall select an appropriate and compatible material as filler for voids created by removal of old insulation or membrane.
2. A core cut should be taken to verify weight of existing components when the roofing system is to be specified over an existing roofing assembly.
3. Entrapment of water between the old and new membrane can damage and deteriorate new insulation/underlayment between the two membranes. If a vapor retarder or air barrier is not specified, WeatherBond recommends the existing membrane be perforated to avoid potential moisture accumulation and to allow the detection of moisture to enable the building owner to take corrective action. This can be accomplished by drilling approximately 3/4" diameter holes every 100 square feet in the existing built-up roof or single-ply membrane (excluding PVC membrane).

4. Existing PVC membrane may be totally removed or the existing membrane must be cut into maximum 10' by 10' sections. All PVC flashings at the perimeter, roof drains and roof penetrations must be removed.

1.03 Quality Assurance

Building codes are above and beyond the intended purpose of this specification. The respective **owner** or **specifier** should consult local codes for applicable requirements and limitations. It is the responsibility of the specifier to review local, state and regional codes to determine their impact on the specified WeatherBond Roofing System.

- A. WeatherBond recommends the use of WeatherBond supplied products for use with WeatherBond Roofing Systems. The performance or integrity of products by others is not the responsibility of WeatherBond.

1.04 System Recommendations

- A. See Tables Below for recommendations regarding
- B. Design Criteria:

1. **TABLE I – Mechanically Attached Roofing Systems – Membrane Fastening Criteria – Steel/Concrete Decks** Identifies fastening density, field membrane width and number perimeter sheets recommended for various wind zones.
2. **TABLE II – Mechanically Attached Roofing Systems – Membrane Fastening Criteria – Wood Decks** Identifies fastening density, field membrane width and number perimeter sheets recommended for various wind zones.
3. **TABLE III – Re-roofing Substrate Criteria** Identifies recommended substrates for re-roofing applications for Fully Adhered and Mechanically Attached roofing systems.
4. **TABLE IV – Fully Adhered Roofing Systems – Underlayment and Fastening Density for Assemblies** Identifies recommended underlayment for Fully Adhered roofing systems based on various wind speed coverage available. The Table also identifies fastening density of adhesive bead spacing and required edge terminations.

**EPDM Reinforced Membrane Fastening
for Mechanically Attached Roofing Systems
22 GA. Steel Deck or Structural Concrete**

Table I

Peak Gust Wind Speed	Max. Building Height	Min. Number of Perimeter Sheets			Field Membrane Width	Perimeter Sheet Width***	Fastening Density* (Field & Perimeter Sheets)
		Building Distance from Coastline					
		Greater than 7 miles	3 to 7 miles	Less than 3 miles			
55 MPH	Up to 60'	1	2	3	10'	6.5'	12" O.C.
					8'	6.5'	12" O.C.
	61' to 100'	2	2	3	10'	6.5'	6" O.C.**
					8'	6.5'	12" O.C.

* Using HPW Fasteners On Steel Deck with Polymer Plates

**12" o.c. Spacing can be utilized by using HPW-XL Fasteners and 2-3/8" Polymer Seam Plates.

***As an option, 9" wide EPDM Peel & Stick RPS can be used beneath the field sheets for perimeter securement.

**EPDM Reinforced Membrane Fastening Criteria
for Mechanically Attached Roofing Systems**

Table II Wood Decks

Peak Gust Wind Speed	Deck Type	Projected Pull-Out Values	Min. Number of Perimeter Sheets		Field Membrane Width	Perimeter Sheet Width	Fastening Density (Field & Perimeter Sheets)
			Distance from Coastline				
			Greater than 7 miles	Less than or equal to 7 miles			
55 MPH	7/16" OSB	210 lbs	2	3	10'	5*	9" O.C.
			2	3	8'	5*	12" O.C.
	15/32" 3-Ply Plywood	240 lbs	2	3	8'	5*	12" O.C.
	15/32" 5-Ply Plywood	530 lbs	1	1	10'	6.5**	12" O.C.
	5/8" OSB	310 lbs	2	3	10'	5*	12" O.C.
			2	3	8'	5*	12" O.C.

*As an option to using 5' perimeter sheets, 9" wide EPDM Peel & Stick RPS can be used beneath the field sheets for perimeter securement.

Table III Re-roofing Substrate Recommendations

Acceptable Roof Deck/Substrate	EPDM Membrane (See Table I and II for minimum membrane thickness)	
RETROFIT / NO TEAR-OFF	Fully Adhered	Mechanically Attached
Existing Smooth Surface BUR or Mineral Surface Cap Sheet	Direct Application	Direct Application
Gravel Surfaced BUR	Insulation	Insulation
Coal Tar Pitch	Insulation	Insulation
Modified Bitumen	Direct Application	Direct Application
Existing Single-Ply	Insulation	Direct Application (1)
Sprayed-in-place Urethane	Complete Tear-off Required	Complete Tear-off Required

(1) Direct application over existing PVC is not recommended

NOTE: Refer to Roof Deck and Substrate Criteria Table in Part III for additional installation recommendations.

Underlayment/Insulation & Recommended Attachment Assemblies for Fully Adhered Roofing Systems

Table IV

Other Requirements are Listed in Additional Design Considerations following this Table.

Maximum Peak Gust Wind Speed	Minimum Membrane Underlayment	Insulation/Underlayment Attachment			Metal Edging
		# of Fasteners per 4' x 8' board size (1)	Adhesive Ribbon Spacing for 4' x 4' size board		
			Field	Perimeter	
55 MPH	1" (20 psi) Polyisocyanurate	16	12" (2)(3)	6" (3)	WeatherBond Drip Edge
	1-1/2" (20 psi) Polyisocyanurate	10	12" (2)(3)	6" (3)	
	2"(20 psi) Polyisocyanurate	8	12" (2)(3)	6" (3)	

(1) For Building heights between 51-100', enhance 12'-wide perimeter with 50% more fasteners and plates.

(2) Gravel Surface BUR - Field @ 6" O.C. / Perimeter @ 4" O.C.

(3) Steel Decks - Field & Perimeter @ 6" O.C.

Additional Design Considerations

- 1 – Refer to Tables I & II paragraph 1.05 for recommended membrane thickness
- 2 - Building height should not exceed 100'
- 3 - Local Wind Zone per ASCE 7 shall not exceed 130 mph*
- 4 - Acceptable decking: 22-gauge or heavier steel, structural concrete, 1-1/2" wood plank, or 3/4" plywood.
- 5 - All "T-joints" must be overlaid with appropriate flashing material. Refer to splicing and flashing details for specific requirement.

- C. The formation or presence of mold or fungi in a building is dependent upon a broad range of factors including, but not limited to, the presence of spores and nutrient sources, moisture, temperatures, climatic conditions, relative humidity, and heating/ventilating systems and their maintenance and operating capabilities. These factors are beyond the control of WeatherBond and WeatherBond shall not be responsible for any claims, repairs, restoration or damages relating to the presence of any irritants, contaminants, vapors, fumes, molds, fungi, bacteria, spores, mycotoxins, or the like in any building or in the air, land, or water serving the building.

1.05 Product Delivery, Storage and Handling

- A. Deliver materials to the job site in **original**, unopened containers.
- B. When loading materials onto the roof, the Roofing Contractor must comply with the requirements of the specifier/owner to prevent overloading and possible disturbance to the building structure.
- C. Job site storage temperatures in excess of 90° F (32° C) may affect shelf life of curable materials (i.e., uncured flashing, adhesives, sealants, primers, P&S Seam Tape and Peel & Stick Flashing/Accessories).
- D. **When the temperature is expected to fall below 40°F (4°C)**, outside storage boxes should be provided on the roof for temporary storage of liquid adhesives, sealants, primers, Peel & Stick Seam Tape and Peel & Stick Flashing/accessories. Containers must be rotated to maintain their temperature above 40° F (4°C).

NOTE: Prolonged exposure of Peel & Stick flashing and P&S Seam Tape to temperatures below 40°F (4°C) will cause the pre-applied adhesive tape to lose tack and in extreme cases, not bond to the substrate. Refer to

Spec Supplement E-02-22 "EPDM Membrane Splicing and Slice Repairs" for application procedures in colder temperatures.

- E. Do not store adhesive containers with opened lids due to the loss of solvent, which will occur from flash off.
- F. Insulation/underlayment must be stored so it is kept dry and is protected from the elements. Store insulation on a skid and completely cover with a breathable material such as a tarp or canvas. If the insulation is lightweight, it should be weighted to prevent possible wind damage.

Part II- Products

2.01 Membrane

A. WeatherBond (Black and White) Non-Reinforced EPDM Membranes

1. Cured non-reinforced EPDM (Ethylene, Propylene, Diene Terpolymer) compounded elastomer.

WeatherBond 45- (Black Membrane Only), 60-, or 90-mil thick Non-Reinforced EPDM membrane is available in **Black** or **White**. WeatherBond Gray is only available in 60-mil. WeatherBond White membranes are installed with the white surface facing up. WeatherBond (black) membrane with thickness up to 60-mil can be available in widths up to 50' and lengths up to 150' (200' for 45-mil membrane only). WeatherBond White membrane with thickness of 60-mil is available up to 30' widths and lengths up to 150' long. WeatherBond Black/WeatherBond White 90-mil membranes and WeatherBond Gray 60-mil membranes are available in widths up to 10' and lengths up to 100'. Membrane conforms to ASTM D4637, Type I (non-reinforced).

2. **WeatherBond Clean (black) EPDM Membrane** (mica dust has been removed during manufacturing) is available for sheets maximum 10' wide.
3. **WeatherBond Gray Non-Reinforced EPDM Membrane** is available with and without FAT.
4. Refer to the physical properties listed on the following pages

B. WeatherBond Reinforced EPDM Membranes

1. Cured reinforced EPDM (Ethylene, Propylene, Diene Terpolymer) compounded elastomer. **WeatherBond Reinforced EPDM Membrane** is available only in black.

45-, 60- or 75-mil thick WeatherBond Reinforced EPDM Membrane is available in sizes referenced in Table below. Reinforced membrane with polyester fabric conforms to ASTM D4637, Type II (reinforced). All sheets referenced in table are available with 3" or 6" factory applied P&S Seam Tape.

WeatherBond Reinforced Membrane Size Availability*			
Membrane Thickness	Sheet Sizes		
45-mil	5' or 6.5' X 100'	-	10' x 50' or 100'
60-mil	5' or 6.5' X 100' 5' x 200'	8' x 100'	10' x 50' or 100'
75-mil	-	-	10' x 50' or 100'

*Contact WeatherBond for other custom sizes available.

2. **60-mil thick WeatherBond WHITE Reinforced EPDM** membrane is available in a 10' x 100' sheet size.
3. Refer to the physical properties listed on the following pages

WEATHERBOND 45-, 60-, AND 90-MIL THICK NON-REINFORCED EPDM MEMBRANE

NOTE: Although 60-mil Non-Reinforced EPDM is recommended for Adhered Roofing Systems, 45-mil thick FR Non-Reinforced EPDM may be utilized, **if specified.**

WEATHERBOND BLACK/WEATHERBOND WHITE NON-REINFORCED MEMBRANES						
Physical Property	Test Method	ASTM SPEC. (Pass)	Typical			
			45-mil	60-mil	60-mil	90-mil
			FR	FR	White & Gray	WB Black FR/ WB White
Tolerance on Nominal Thickness, %	ASTM D 412	±10	±10	±10	±10	±10
Weight, lb./ft ² (kg/m ²)			0.26 (1.3)	0.35 (1.7)	0.39 (1.9)	0.59 (2.9)**
Tensile Strength, min, psi (MPa)	ASTM D 412	1305 (9)	1600 (11)	1600 (11)	1600 (11)	1600 (11)
Elongation, Ultimate, min, %	ASTM D 412	300	480	465	540	540
Tear Resistance, min, lbf/in (kN/m)	ASTM D 624 (Die C)	150 (26.3)	200 (35.0)	200 (35.0)	200 (35.0)	200 (35.0)
Factory Seam Strength, min.	Modified ASTM D 816	Membrane Rupture	Membrane Rupture	Membrane Rupture	Membrane Rupture	Membrane Rupture
Resistance to Heat Aging* Properties after 4 weeks @ 240°F (116°C)	ASTM D 573					
Tensile Strength, min, psi (MPa)	ASTM D 412	1205 (8.3)	1500 (10.3)	1450 (10)	1345 (9.3)	1450 (10)
Elongation, Ultimate, min, %	ASTM D 412	200	225	280	280	280
Tear Resistance, min, lbf/in (kN/m)	ASTM D 624	125 (21.9)	215 (37.6)	215 (37.6)	185 (32.4)	215 (37.6)
Linear Dimensional Change, max, %	ASTM D 1204	±1.0	-0.4	-0.5	-0.2	-0.5
Ozone Resistance* Condition after exposure to 100 ppm Ozone in air for 168 hours @ 104°F (40°C) Specimen is at 50% strain	ASTM D 1149	No Cracks	No Cracks	No Cracks	No Cracks	No Cracks
Brittleness Temp., max, deg. F (deg. C)*	ASTM D 746	-49 (-45)	-49 (-45)	-49 (-45)	-67 (-55)	-49 (-45)
Resistance to Water Absorption* After 7 days immersion @ 158°F (70°C) Change in mass, max, %	ASTM D 471	+8.0, -2.0	[+2]	[+2]	[+3.3]	[+2.0]
Water Vapor Permeance* max, perm	ASTM E 96 (Proc. B or BW)	0.1	0.05	0.03	0.02	0.03
Resistance to Outdoor (Ultraviolet) Weathering* Xenon-Arc, total radiant exposure at .70 W/m ² irradiance, 176°F (80° C) black panel temp.	ASTM D 4637 Conditions	No Cracks No Cracking @7560kJ/m ²	No Cracks No Cracking @ 41580 kJ/m ²	No Cracks No Cracking @ 41580 kJ/m ²	No Cracks No Cracking@ 25200 kJ/m ²	No Cracks No Cracking @ 41580 kJ/m ² (black) 25200 kJ/m ² (white)
* Not a Quality Control Test due to the time required for the test or the complexity of the test. However, all tests are run on a statistical basis to ensure overall long-term performance of the sheeting.						
** WeatherBond White 90-mil Membrane Weight in lb/ft ² (kg/m ²) is equal to 0.60 (2.9)						

**WEATHERBOND (BLACK) 45-, 60- OR 75-MIL THICK REINFORCED EPDM
STANDARD AND FIRE RETARDANT (FR)**

The membrane is used for:

1. WeatherBond Fully Adhered Roofing Systems
2. WeatherBond Mechanically Attached Roofing Systems

WEATHERBOND REINFORCED MEMBRANES						
Physical Property	Test Method	ASTM SPEC. (Pass)	Typical			
			45-mil	60-mil	60-mil	75-mil
			Standard	FR	WB White	Standard
Tolerance on Nominal Thickness, %	ASTM D 751	±10	±10	±10	±10	±10
Weight, lb/ft ² (kg/m ²)			0.27 (1.3)	0.39 (1.9)	0.37 (1.8)	0.48 (2.3)
Thickness Over Scrim, min. in.(mm)	ASTM D 4637 Annex	0.015 (.381)	0.016 (.406)	0.020 (.508)	0.020 (.508)	0.032 (0.81)
Breaking Strength, min, lbf (N)	ASTM D 751 Grab Method	90 (400)	140 (623)	140 (623)	210 (930)	177 (787)
Elongation, Ultimate, min, %	ASTM D 751 Grab Method	250 **	480**	480**	480**	500**
Tear Strength, min, lbf (N)	ASTM D 751 B Tongue Tear	10 (45)	70 (311)	70 (311)	70 (311)	70 (311)
Brittleness Temp., max. deg. F (deg. C)*	ASTM D 2137	[-49] (-45)	[-49] (-45)	[-49] (-45)	[-49] (-45)	[-49] (-45)
Resistance to Heat Aging* Properties after 4 weeks @ 240°F	ASTM D 573					
Breaking Strength, min, lbf (N)	ASTM D 751	80 (355)	182 (823)	182 (823)	250 (1,110)	182 (823)
Elongation, Ultimate, min, %	ASTM D 751	200**	250**	250**	250**	250**
Linear Dimensional Change, max, %	ASTM D 1204	±1.0	-1.0	-1.0	-1.0	-1.0
Ozone Resistance* Condition after exposure to 100 pphm Ozone in air for 168 hours @ 104°F (40°C) Specimen wrapped around 3" mandrel	ASTM D 1149	No Cracks	No Cracks	No Cracks	No Cracks	No Cracks
Resistance to Water Absorption* After 7 days immersion @ 158°F (70°C) Change in mass, max, %	ASTM D 471	+8.0, -2.0	[+5.5**]	[+5.5**]	[+5.5**]	[+5.5**]
Factory Seam Strength, min.	Modified ASTM D 816	Membrane Rupture	Membrane Rupture	Membrane Rupture	Membrane Rupture	Membrane Rupture
Resistance to Outdoor (Ultraviolet) Weathering* Xenon-Arc total radiant exposure at .70 W/m ² irradiance, 176°F (80° C) black panel temp.	ASTM D 4637 Conditions	No Cracks No Cracking @ 7560kJ/m ²	No Cracks No Cracking @ 35320kJ/m ²	No Cracks No Cracking @ 35320 kJ/m ²	No Cracks No Cracking @ 35,320 kJ/m ²	No Cracks No Cracking @ 35320 kJ/m ²
* Not a Quality Control Test due to the time required for the test or the complexity of the test. However, all tests are run on a statistical basis to ensure overall long-term performance of the sheeting.						
** Specimens to be prepared from coating rubber compound, vulcanized in a similar method to the reinforced product.						

2.02 Insulations/Underlayments

A. General

1. Roof insulation thickness must be determined by the thermal value required for each project and may be subject to code approval limitations. On projects where a vapor retarder is used, the specifier must calculate insulation thickness to ensure the temperature at the vapor retarder will not fall below the calculated dew point.
2. Multiple layers of insulation are recommended with all joints staggered between layers.
3. For minimum recommended R-Values, previously published by American Society of Heating and Air-Conditioning Engineers (ASHRAE), consult local building code official for applicable requirements.
4. For insulation fastening pattern and densities refer to WeatherBond Applicable Details and Design Reference DR-05-22 "Insulation Fastening Patterns".
5. Any of the WeatherBond insulation/underlayment may be specified subject to design restrictions included with each table

B. WeatherBond Polyisocyanurate

Table B1 Polyisocyanurate (See below for product descriptions)				
Insulations / Underlayment	Minimum Thickness	ASTM	Roofing System Acceptability	
			Adhered	Mechanically Attached
WeatherBond XP Polyiso	*1.5"	C1289, Type II, Class 1, Grade 2 or 3	√	√
WeatherBond XFP Polyisocyanurate	*1.5"	C1289, Type II Class 2, Grade 2 or 3	√	√
WeatherBond XFP HD Polyiso Composite (XFP HD)	2"	C1289, Type IV, Class 2, Grade 2 or 3	√	√
WeatherBond XP-NB Polyiso Composite (OSB)	1.5"	C1289, Type V, Class 1, Grade 2 or 3	√	√
Design Restrictions				
<ul style="list-style-type: none"> - Higher wind speed may require the use of a cover board over Polyiso Insulation, refer to Tables in Paragraph 1.04 for applicable recommendations. - Maximum Flute Spanability shall be limited to 2-5/8" when 1" Minimum Polyiso Insulation is to be used. - Minimum thickness of insulation board may be restricted by wind speed coverage, refer to Table IV in Paragraph 1.05. *1.5" minimum for adhered systems. 1" minimum for mechanically fastened systems or as a base layer for adhered. 				
Notes: N/A = Not Acceptable √ = Acceptable				

XFP HD is listed in Paragraph C4 below.

2. **WeatherBond XP Polyiso** – A foam core insulation board covered on both sides with a medium weight fiber-reinforced felt facer meeting, ASTM C 1289-06, Type II, Class 1, Grade 2 (20 psi) or Grade 3 (25 psi). The product is available in 4' x 8' standard size with a thickness from 1 to 4 inches. 4' x 4' tapered panels are also available.
3. **WeatherBond XFP Polyisocyanurate-** A foam core insulation board covered on both sides with a coated glass fiber mat facer meeting ASTM C 1289-06, Type II, Class 2 (20 psi) or Grade 3 (25 psi). The product is available in 4' x 8' standard size with a thickness from 1 to 4 inches. 4' x 4' tapered panels are also available.
4. **WeatherBond XFP HD Composite** – Composite insulation panel comprised of ½ inch high-density Polyiso cover board laminated during the manufacturing process to XFP rigid Polyiso roof insulation meeting ASTM C1289 Type II, Class 2, Grade 2 (20 psi) or Grade 3 (25 psi). Available in 4' x 8' boards with a thickness from 2" to 4.5". 4' x 4' panels are also available.
5. **WeatherBond XP-NB Polyiso** – XP Polyiso insulation bonded on the bottom side with a medium weight fiber reinforced felt facer and laminated with a top surface of 7/16" or 5/8" thick Oriented Strand Board (OSB) meeting ASTM C 1289-06, Type II, Class 1, Grade 2 (20 psi) or Grade 3 (25 psi). Available in 4' x 8' boards with a thickness from 1-1/2" to 4".

C. **EPS : Expanded Polystyrene**

Table C1 EPS: Expanded Polystyrene (See below for product descriptions)				
Insulations / Underlayment	Minimum Thickness	ASTM	Roofing System Acceptability	
			Adhered	Mechanically Fastened
InsulFoam I	1"	C578 Type I	N/A	N/A
InsulFoam VIII	.75"	C578 Type VIII	N/A	N/A
InsulFoam II	.75"	C578 Type II	N/A	N/A
InsulFoam IX	.75"	C578 Type IX	N/A	N/A
InsulFoam HD Composite (XFP HD)	1.5"	C578 Type (I, VIII, II, or IX)	√	√
InsulLam (Various Cover Boards)	1.5"	C578 Type (I, VIII, II, or IX)	√	N/A
InsulFoam SP	1"	C578 Type VIII	N/A	√
Design Restrictions				
<ul style="list-style-type: none"> - Local Codes must be consulted regarding the acceptance of expanded insulation directly over steel decks. When specified, minimum thickness shall be designated by the manufacturer. - Expanded polystyrene roof insulations cannot be installed directly over coal-tar pitch roof surfaces or existing PVC membranes. A separation layer of minimum 1/2" XFP HD, Recovery Board or Polyiso Insulation shall be used. <p>Notes: N/A = Not Acceptable √ = Acceptable</p>				

R-Tech Fanfold Recover Board is listed in Paragraph C4 below.

2. **InsulFoam I (EPS: Expanded Polystyrene)**- A closed-cell lightweight expanded polystyrene (EPS) that meets ASTM C578, Type I. Nominal density of 1.0 lbs/cubic ft. (pcf) available in 4' x 4' or 4' x 8' sizes with thickness from 1/4" to 40". Custom lengths, widths and tapered boards are available. May be specified beneath WeatherBond Recovery Board, Dens-Deck Prime or Securock.
3. **InsulFoam VIII (EPS: Expanded Polystyrene)** – A closed-cell lightweight expanded polystyrene (EPS) that meets ASTM C578, Type VIII. Nominal density of 1.25 lbs/cubic ft. (pcf) available in 4' x 4' or 4' x 8' sizes with thickness from 1/4" to 40". Custom lengths, widths and tapered boards are available. May be specified beneath Recovery Board, Dens-Deck Prime or Securock.
4. **InsulFoam II (EPS: Expanded Polystyrene)** – A closed-cell lightweight expanded polystyrene (EPS) that meets ASTM C578, Type II. Nominal density of 1.5 lbs/cubic ft. (pcf) available. May be specified beneath Recovery Board, Dens-Deck Prime or Securock.
5. **InsulFoam IX (EPS: Expanded Polystyrene)** – A closed-cell lightweight expanded polystyrene (EPS) that meets ASTM C578, Type IX, Nominal density of 2.0 lbs/cubic ft. (pcf) available in 4' x 4' or 4' x 8' sizes with thickness from 1/4" to 40". Custom lengths, widths and tapered boards are available. May be specified beneath Recovery Board, Dens-Deck Prime or Securock.
6. **InsulFoam HD Composite**- InsulFoam expanded polystyrene (EPS) insulation laminated with a top surface of 1/2" thick XFP HD. Available in 4' x 8' boards with thickness from 1-1/2" to 7".
7. **InsulLam** – InsulFoam expanded polystyrene (EPS) insulation laminated with a top surface of 7/16" or 5/8" thick Oriented Strand Board (OSB), 1/2" Securock, or 1/2" Recovery Board. Available in 4' x 8' boards with thickness from 1-1/2" to 7".
8. **InsulFoam SP** – A closed-cell lightweight expanded polystyrene (EPS) with a factory-laminated fiber glass facer. Nominal density of 1.25 lbs/cubic ft. (pcf), and meets ASTM C578, Type VIII. Designed for low-sloped roof applications that employ mechanically attached membranes.

- D. **XPS: Extruded Polystyrene** – Dimensionally stable with high thermal and low water absorption performance capability. XPS is available in varying compressive strengths thicknesses and sizes. Refer to specific Technical Data Bulletins for physical properties and additional technical information.

Table D1		XPS: Extruded Polystyrene (See below for product descriptions)		
Insulations / Underlayment	Minimum Thicknesses	ASTM	Roofing System Acceptability	
			Fully Adhered	Mechanically Attached
Thermapink 18	.75"	Refer to Technical Data Bulletin	N/A	N/A
Thermapink 25	1"	Refer to Technical Data Bulletin	N/A	N/A
Foamular 400	1"	Refer to Technical Data Bulletin	N/A	N/A
Dow Styrofoam Deckmate Plus	1"	Refer to Technical Data Bulletin	N/A	N/A
Design Restrictions				
<ul style="list-style-type: none"> - Local Codes must be consulted regarding the acceptance of expanded insulation directly over steel decks. When specified, minimum thickness shall be designated by the manufacturer. - Expanded polystyrene roof insulations cannot be installed directly over coal-tar pitch roof surfaces or existing PVC membranes. A separation layer of minimum 1/2" XFP HD, Recovery Board or Polyiso Insulation shall be used. - Refer to related products listed in Spec Supplement P-01-11 "Related Products" for other products which may be suitable for use. 				
Notes: N/A = Not Acceptable ✓ = Acceptable				

2. **Thermapink 18 or 25 Extruded Polystyrene**
3. **Foamular 400 Extruded Polystyrene**
4. **Dow Styrofoam Deckmate Plus Extruded Polystyrene**

E. Cover Boards/Slip Sheets

Table E1 Cover Boards (See below for product descriptions)				
Insulations / Underlayment	Minimum Thickness	ASTM	Roofing System Acceptability	
			Adhered	Mechanically Attached
XFP HD	.5"	C1289-06, Type II, Class 4 (109 psi)	√	√
XFP HD Plus	.5"	C1289-06, Type II, Class 4 (109 psi)	√	√
XP HD	.5"	C1289-06, Type II, Class 1, Grade 3	N/A	√
Securock Cover Board	.25"	Refer to Technical Data Bulletin	√	√
Recovery Board	.5"	C208 Grade 2	√	√
DensDeck StormX Prime	.625"	C1177	√	√ (1)
DensDeck Prime	.25"	C1177	√	√ (1)
DensDeck	.25"	C1177	N/A	√ (1)
R-Tech Fanfold Recovery Board	.5"	C578 Type (I, VIII, II. or IX)	N/A	√

Design Restrictions

- Recovery Board and R-Tech Fanfold not recommended for direct use over Type B and F steel decks.
- XFP HD not recommended for direct use over steel decks in lieu of thermal barrier. Fire testing standards yet to be established.
- Securock Cover Board, Recovery Board, DensDeck StormX Prime, DensDeck Prime or DensDeck may not be used directly over New or Existing Lightweight Insulating Concrete Decks existing or Structural Concrete.
- DensDeck, DensDeck Prime and DensDeck StormX Prime are not recommended for use directly over existing roofing membrane
- R-Tech Fanfold primarily for use in existing roof re-covers applications or directly over structural or lightweight insulating concrete.
- To be used for Mechanically Attached on new construction projects with Lightweight Insulating Concrete, Fiber Cement or Gypsum Deck

(1) Permitted with roofs with slopes greater than 2" per foot for compliance with external fire codes, refer to UL listings or contact WeatherBond.

Notes: N/A = Not Acceptable √ = Acceptable

2. **XFP HD** – A rigid insulation panel composed of a high-density (109 psi), closed-cell polyisocyanurate foam core laminated to coated-glass fiber-mat facer for use as a cover board or recover board. Available 1/2" thick 4' x 8' panel weight 11 lbs with an R-value of 2.5.
3. **XFP HD Plus** – A rigid insulation panel composed of a high-density (109 psi max), closed-cell polyisocyanurate foam core laminated to premium-performance coated-glass fiber-mat facer for use as a cover board or recover board. Available 1/2" thick 4' x 8' panel weight 11 lbs with an R-value of 2.5. Meets an FM 1-90 using only 8 fasteners per 4' x 8' board.
4. **XP HD** – a closed-cell polyisocyanurate foam core insulation board covered on both sides with glass-reinforced felt (GRF) facer meeting ASTM C 1289, Type II, Class 1, Grade 3. The product is available in 4' x 4' and 4' x 8' standard sizes with a thickness of one half inch.
5. **Securock Cover Board** – A uniform composition of fiber-reinforced with no facer for use as a cover board or a thermal barrier. Available in 1/4" to 5/8" thick and 4' x 4' or 4' x 8' size boards. Long uninterrupted runs (>200') may require slight gapping due to thermal expansion.
6. **Recovery Board** – A 1/2" or 1" thick high-density wood fiberboard with an asphalt coated facer for use as a cover board or recover board. Available 1/2" or 1" thick and 4' x 4' or 4' x 8' size boards.
7. **DensDeck StormX Prime** – a reinforced gypsum cover board with an enhanced, moisture-resistant core and coated glass mat facers on the top and bottom side. The top surface is pre-primed and

provides excellent bond strength for adhered membrane for use as a cover board. DensDeck StormX Prime is extremely durable and is approved for use in assemblies meeting FM's Very Severe Hail (VSH) Classification. Available in 5/8" thickness and 4' x 4' or 4' x 8' size boards.

8. **DensDeck Prime** – Gypsum core that incorporates glass-mat facings on the top and bottom side. The top surface is pre-primed and provides excellent bond strength for fully adhered membrane for use as a cover board. Available in 1/4" to 5/8" and 4' x 4' or 4' x 8' size boards.
9. **DensDeck Cover Board** – Gypsum core that incorporates glass-mat facings on the top and bottom side for use as a cover board. Available in 1/4" to 5/8" and 4' x 4' or 4' x 8' size boards.
10. **R-Tech FanFold Recover Board** – Closed-cell lightweight expanded polystyrene (EPS) with polymeric laminated faces which meets ASTM C578 for use as a recover board. Polymeric facer compatible with PVC membrane, while metallic side used with EPDM. Available in thicknesses of 3/8" to 3/4" with coverage 4' x 50' (2 squared). 4' x 8' units are also available.

2.03 Related Materials

A. Flashing

1. **WeatherBond Black/WeatherBond White Peel & Stick Cured Cover Strip:** A 6" and 9" widths and 100' long and 12" wide by 50' long WeatherBond Black or WeatherBond White 60-mil cured EPDM membrane laminated to a nominal 28-mil cured Peel & Stick Tape. The Cured Cover Strip is ideal for flashing gravel stops, metal edging and WeatherBond Seam Fastening Plates.
2. **WeatherBond (black and white) Peel & Stick Uncured Flashing:** A 6" x 100' and 9" or 12" wide by 50' long, 60-mil thick WeatherBond Black or WeatherBond White **uncured** EPDM Flashing laminated to a 28-mil Peel & Stick Tape used in conjunction with EPDM Primer as an option to WeatherBond Black/WeatherBond White Uncured Flashing.

WeatherBond's black uncured flashings are to be used in conjunction with WeatherBond Black Roofing Systems and the WeatherBond White uncured flashing is to be used in conjunction with WeatherBond White Roofing Systems. WeatherBond Black/WeatherBond White Uncured Flashing is used mainly to flash inside and outside corners, pipes, scuppers and field fabricated pourable sealer pockets when the use of WeatherBond pre-fabricated flashing accessories is not feasible.

3. **WeatherBond Black/WeatherBond White Peel & Stick Curb Flashing** – A 20" wide by 50' long WeatherBond Black or WeatherBond White cured 60-mil thick EPDM membrane with 5" wide Peel & Stick Tape along one edge to be used to flash curbs/skylights, etc.
4. **WeatherBond Peel & Stick Curb Flashing** – A 20" wide by 50' long WeatherBond (black) cured 60-mil thick EPDM membrane with 2 sections of Peel & Stick Tape (6" and 12") used to flash curbs/skylights, etc.
5. **WeatherBond Peel & Stick "T" Joint Covers** – A factory cut 6" x 6" uncured 60-mil thick EPDM flashing (with rounded corners) laminated to a nominal 28-mil Peel & Stick Tape, used to overlay field splice intersections and to cover field splices at angle changes. WeatherBond (black) is available in 6" x 6" and 12" x 12" sizes. WeatherBond White and WeatherBond (gray) available in 6" x 6" size.
6. **WeatherBond White Peel & Stick Corner/T-Joint Cover** – A 7" by 9" precut 60-mil thick (white) Uncured Flashing with a 28-mil Peel & Stick Tape; used for inside and outside corners, to overlay field splice intersections, and to cover field splices at angle changes.
7. **WeatherBond Black Inside/Outside Corners** – A 7" by 9" precut 60-mil thick Uncured Flashing with a 28-mil Peel & Stick Tape. Available in black, gray, or white.
8. **WeatherBond Black/WeatherBond White Peel & Stick Pipe Seals** with Peel & Stick Tape on the deck flange are available for use with WeatherBond Black/WeatherBond White Roofing Systems:
 - a. WeatherBond Black Peel & Stick Pipe Seals are available in sizes: 1/2" to 3" and 1" to 6".
 - b. WeatherBond White and WeatherBond (gray) Peel & Stick Pipe Seals are available in one size: 1" to 6"

9. **WeatherBond Black/ WeatherBond White Pourable Sealer Pocket:** A pre-fabricated Pourable Sealer Pocket which consists of a 2" wide plastic support strip with factory-applied, adhesive backed uncured Flashing; black available in 4" 6" and 8" diameters for WeatherBond Black EPDM; 6" diameter for WeatherBond (gray). White available in 6" and 8" diameter only for WeatherBond White EPDM.

B. SEAM TAPES, PRIMERS, ADHESIVES AND SEALANTS/CLEANERS

Refer to Technical Data Bulletins for material coverage rates and proper usage. Prior to the use of any of the products listed below, consult the Material Safety Data Sheets for applicable cautions and warnings.

1. **WeatherBond P&S Seam Tape** – A 3" or 6" wide (used for mechanically attached roofing systems) by 100' long Splice Tape used for splicing adjoining sections of EPDM membrane. Complies with the South Coast Air Quality Management District Rule 1168.
2. **WeatherBond Multipurpose Primer** – A solvent-based primer used to prepare the surface of EPDM membrane for application of P&S Seam Tape or Peel & Stick products. Available in 1 gallon pails and pressurized cylinders.
3. **Low VOC EPDM Primer** – A low VOC (volatile organic compound) primer (less than 250 grams/liter) for use with P&S Seam Tape or Peel & Stick products. Available in 1 gallon pails and in pressurized cylinders.
4. **WeatherBond's Lap Sealant** – A heavy-bodied material used at splice intersections beneath "T"-joint covers and at cut edges of reinforced EPDM membrane.
5. **WeatherBond Weathered Membrane Cleaner** – A clear, solvent-based cleaner used to loosen and remove dirt and other contaminants from the surface of exposed EPDM membrane (for repairs, etc.) prior to applying WeatherBond EPDM Primer. Available in 1 and 5-gallon pails.
6. **LC-60 Bonding Adhesive** – A high-strength, yellow colored, synthetic rubber adhesive used for bonding WeatherBond EPDM membranes to various surfaces.
7. **Low VOC Bonding Adhesive** – A low VOC (volatile organic compound) bonding adhesive (less than 250 grams/liter) used for binding WeatherBond Black/WeatherBond White EPDM membranes to various surfaces. Adhesive is available in 5 gallon pails.
8. **Aqua Base 120 Bonding Adhesive** (for use in areas where volatile organic compound, VOC, regulations are in effect): A semi-pressure-sensitive water based adhesive; used as a 2-sided contact adhesive for bonding WeatherBond EPDM membrane to various surfaces. Complies with the South Coast Air Quality Management District Rule 1168.
9. **CAV-GRIP III Low-VOC Adhesive/Primer:** a low-VOC, spray-applied aerosol contact adhesive and primer used for a variety of applications: adhering standard WeatherBond EPDM and TPO membranes to horizontal and vertical surfaces, adhering WeatherBond Fleece membranes to vertical surfaces, as a primer for VapAir Seal 725TR, and as an unexposed asphalt primer for Flexible DASH for insulation attachment.
10. **Water Cut-Off Mastic** – A one-component, low viscosity, self-wetting, Butyl blend mastic used as a sealing agent between the EPDM membrane or Uncured Flashing and applicable substrates.
11. **G-400 Pourable Sealer** – A black, two-component, solvent-free, polyurethane based product used for tie-ins and as a sealant around hard-to-flash membrane penetrating objects such as clusters of pipes and for daily seal when the completion of flashings and terminations cannot be completed by the end of each work day.
12. **One-Part Pourable Sealer** – A black, one-component, moisture curing, elastomeric polyether sealant used for attaching lightning rod bases and ground cable clips to the membrane surface and as a sealant around hard-to-flash penetrations such as clusters of pipes.
13. **Universal Single-Ply Sealant** – A one-part polyether, non-sagging sealant designed for sealing expansion joints, control joints and counter flashings. Available in white only.

2.04 Fastening Components

A. Reinforced Perimeter Strip (RPS)

1. **WeatherBond Peel & Stick RPS (Reinforced Perimeter Strip):** A 6" or 9" wide, nominal 45-mil thick clean, cured reinforced EPDM black membrane with 3" wide Peel & Stick Tape laminated along one edge for the 6" wide RPS and along both edges for the 9" wide RPS.

- a. **6" wide Peel & Stick RPS** is used horizontally or vertically at the base of walls, curbs, etc., in conjunction with Fastening Plates or Bars below the EPDM deck membrane for additional membrane securement.
 - b. **9" wide Peel & Stick RPS** is utilized for perimeter membrane securement on WeatherBond RBR mechanically attached roofing systems and primary securement on Metal Retrofit Roofing Systems. Packaged in rolls 100' long.
2. **WeatherBond White Peel & Stick RPS** (Reinforced Perimeter Strip) – A 6" wide, nominal 45-mil thick clean, cured, white reinforced EPDM membrane with 3" wide Peel & Stick Tape laminated along one edge. Used on WeatherBond white fully adhered roofing systems.

B. Fasteners

The following Table illustrates criteria for fastening of WeatherBond Insulation with the referenced roof deck and include minimum penetration recommendations and pilot hole criteria.

Deck Type	WeatherBond Fasteners (1)	Min. Penetration	Pilot Hole Depth	Pilot Hole Diameter
Steel or Lightweight Insulating Concrete over Steel	ASAP or InsulTite™	3/4"	N/A	N/A
Structural Concrete, rated 3,000 psi or greater	CD-10	1"	Note (2)	7/32"
	MP 14-10	1"	Note (2)	3/16"
Wood Plank, min. 15/32" thick Plywood or min. 7/16" OSB	HPW, ASAP or InsulTite	Min. 1" (3)	N/A	N/A
Cementitious Wood Fiber	Polymer Gyptec	1-1/2"	Note (4)	N/A
Cementitious Wood Fiber	Lite-Deck Fastener	2"	Note (4)	N/A
Gypsum	Polymer Gyptec	1-1/2"	Note (2)	7/16", 1/2" or 9/16" (5)
Gypsum	Lite-Deck Fastener	2"	Note (5)	Note (6)

Notes: N/A = Not Applicable

- (1) Only 3" diameter insulation fastening plates can be used for insulation attachment.
- (2) The pilot hole must be predrilled to a sufficient depth to prevent contact between the fastener point and any accumulated dust in the predrilled hole. This will help prevent bottoming out of the fastener during installation.
- (3) For wood planks only, fastener penetration shall not exceed 1-1/2".
- (4) Most cementitious wood fiber decks do not require pre-drilling; however, WeatherBond should be contacted prior to installation for verification of specific types that may require a pilot hole to be predrilled.
- (5) Pilot hole size may be varied to maximize pullout resistance.
- (6) Gypsum hardness varies, and the desired pullout may determine pilot hole size. This could range from 1/4" to 5/16".

All WeatherBond Fasteners listed below can be used with WeatherBond (black and white) Roofing Systems. Refer to the applicable specification for specific requirements.

1. **HPW Fastener** – A threaded E-coat square head fastener for insulation and reinforced membrane attached (mechanically attached systems) in conjunction with 2" diameter polymer plates. Used into steel, wood plank, minimum 15/32" thick plywood or minimum 7/16" thick oriented strand board (OSB).
2. **HPW-XL Fastener** – An oversized diameter (.315") steel, threaded fastener used in conjunction with HPW-XL Polymer Plates for membrane securement into minimum 22 gauge steel or wood decks on mechanically attached roofing systems.
3. **InsulTite ASAP** – WeatherBond's InsulTite Fastener pre-assembled with a 3" diameter plate used for insulation attachment only on fully adhered and mechanically attached roofing systems. Installed using Olympic Fasteners' Fastening Tool.
4. **InsulTite Fasteners** – A threaded Philips drive fastener used with WeatherBond Insulation Plates for insulation attachment to steel or wood decks.
5. **MP 14-10 Concrete Fastener** – A #14 threaded fastener with a #3 Philips driver used for minimum 3,000 psi concrete decks.
6. **CD-10 Nail-In Fastener** – A hammer-driven, non-threaded E-Coat Fastener for use with structural concrete decks rated 3,000 psi or greater.

7. **Polymer Gyptec Fastener** – A non-penetrating, plastic fastener and corresponding plate used with lightweight deck substrates such as fibrous cement and gypsum.
8. **Term Bar Nail-In** – A 1-1/4" long expansion anchor with threaded drive pin used for fastening WeatherBond Termination Bar or Seam Fastening Plates to concrete, brick or block walls. The fastener is set by hammering the drive pin into place.
9. **Sure-Tite (K-Fast) Fasteners** – A nominal 33-mil diameter fastener incorporating an oversized #3 Philips head used for membrane securement or mechanically attached roofing systems in conjunction with Sure-Tite (K-Fast) Fastening Bars into steel decks.
10. **Lite-Deck Fastener: A deep, coarse threaded fastener used to secure insulation to gypsum and cementitious wood fiber decks in conjunction with Lite-Deck Plates.**

C. **Fastening Plates And Bars**

1. **Polymer Seam Plate** – A 2" diameter plastic barbed fastening plate used with WeatherBond HPW Fasteners for membrane and Peel & Stick RPS securement for mechanically attached roofing systems over steel roof decks.
2. **HPW-XL Plate** – A 2-3/8" diameter plastic barded listening plate used with HPW-XL Fasteners for membrane and Peel & Stick RPS securement for mechanically attached roofing systems over steel roof decks.
3. **Seam Fastening Plates** – A 2" diameter metal plate used for insulation attachment on mechanically attached roofing systems or membrane securement on fully adhered roofing systems in conjunction with the appropriate WeatherBond Fastener.
4. **Insulation Fastening Plates** – A nominal 3" diameter metal plate used for insulation attachment in conjunction with the appropriate WeatherBond Fastener.
5. **Gyptec Plates** – A 3" (26-gauge) steel plate for insulation and a 2" (22 gauge) steel plate for membrane attachment. The plates are stamped Galvalume-coated steel.
6. **Polymer Batten Strip** – A 1" wide by 1/20" thick polymer bar which is pre-punched 6" o.c. packaged in 250' long coils used for membrane securement on mechanically attached roofing system in conjunction with HPW or HPWX Fasteners. Refer to applicable Technical Data Bulletin.
7. **K-Fast (Sure-Tite) Fastening Bar** – A 1" x .040" x 10' long galvalume-coated steel fastening bar used primarily for membrane securement in conjunction with K-Fast/Sure-Tite Fasteners on mechanically attached roofing systems.
8. **Metal Fastening Bar** – A 1" wide metal bar which is pre-punched 6" o.c. and packaged in 10' long strips to be used for membrane securement on mechanically attached roofing systems.

2.05 Insulation Securement Adhesive

1. **Flexible DASH Dual Tank:** A two component (Part A and B), extrusion applied, low rise adhesive for bonding insulation to various surfaces. Flexible DASH Dual Tanks utilize an HFO blowing agent. HFO (hydrofluoroolefin) blowing agents are widely recognized as the next-generation environmentally friendly blowing agent, replacing their HFC (hydrofluorocarbon) predecessor. When extruded at 12" on center the coverage rate is 3,500 to 3,700 sq.ft. per set of Dual Tanks.
2. **Flexible DASH Dual Cartridge and 5-gallon Jug Adhesive:** A two component (Part A and B), extrusion applied, low rise adhesive for bonding insulation to various surfaces. When extruded at 12" on center the coverage rate is 400-600 sq.ft. per carton of Dual Cartridges or 2,000-2,500 sq.ft. per set of 5-gallon Jug Adhesive.
3. **OlyBond 500™ BA** – A two-component, polyurethane, low-rise expanding adhesive used to bond insulation to various substrates. Packaged in 5-gallon pails of Part A and Part B formulations that are applied using a mechanical dispense system. Applied in 1/2" to 3/4" beads or ribbons at the rate of 1 gallon per 150-250 square feet for 12" o.c. bead spacing. Perimeter bead spacing patterns and acceptable insulation and deck types are listed in the applicable Technical Data Bulletin.
4. **OlyBond Spot Shot** – A two-component, polyurethane construction grade, low-rising expanding adhesive designed for bonding insulation to various substrates. Applied in 1/2" to 3/4" beads or ribbons using a portable

1:1 applicator (oversized, dual-cartridge caulking gun). Refer to the Technical Data Bulletin for bead spacing with reference to building height.

2.06 Vapor/Air Barrier

A. General

The use of a vapor retarder to protect insulation and reduce moisture accumulation within an insulated roofing assembly should be investigated by the specifier, especially on projects with high interior humidity, such as, swimming pools, breweries, pulp mills, etc.

If insulation is to be fully adhered to the vapor retarder with DASH Adhesive, the vapor retarder must be compatible and shall be fully adhered to the substrate. Available products include WeatherBond supplied "peel and stick" rubberized asphalt membrane with compatible film coating (WeatherBond's 725 Air and Vapor), and spray or roller applied Butyl coatings. Installation requirements for WeatherBond's 725 Air and Vapor Barrier are identified in Spec Supplement G-07-11 "Application Procedures for 725 TR Air and Vapor Barrier" in the WeatherBond Technical Manual.

1. **VapAir Seal 725 TR Temporary Roof Air and Vapor Barrier** – A 40-mil thick composite consisting of 35-mil self-adhering rubberized asphalt membrane laminated to a 5-mil UV resistant poly film with an anti-skid surface which is fully compatible with DASH Adhesive. 725TR can also function as a temporary roof for up to 120 days. Available in rolls 39" wide by 75' long (244 square feet).
2. **VapAir Seal MD Air and Vapor Barrier** – a reinforced composite aluminum foil with self-adhesive SBS backing and removable poly release film. Used for direct application over metal decks. Available in rolls 42.5" wide by 131.23" long (460 square feet).
3. **CAV-GRIP III Low-VOC Adhesive/Primer** – Is a low VOC contact adhesive used to prime surfaces for the application of 725TR. It features a quick dry time and ease of application from the self-contained pressurized cylinder. CAV-GRIP III is an alternate, high-strength, adhesive using a blend of VOC exempt and non-exempt solvent which complies with the State of California Clean Air Act of 1988 (updated in 1997). Coverage rate is 2,500-3,000 sq. ft. per cylinder.
4. **CCW 702/702 LV Primer** – A single component, solvent based, high tack primer used to provide maximum adhesion between WeatherBond 725 TR Temporary Roof Air and Vapor Barrier and an approved substrate. Applied by spray or long nap roller with a coverage rating ranging from approximately 250 square feet per gallon on smooth finishes (i.e., concrete) to 75 square feet per gallon on porous surfaces (i.e., Dens-Deck Prime gypsum board). Available in 5-gallon containers.

2.07 Edges And Terminations

A. General

Products listed below can be used with any of the available WeatherBond Roofing Systems. Refer to the applicable WeatherBond details and installation instruction manuals for specific installation criteria.

B. Products

1. **WeatherBond Drip Edge:** Designed for use on Fully Adhered and Mechanically Attached Roofing Systems. Includes a 22 gauge continuous 12' pre-punched 90-degree angle cleat and 12' long fascia sections. Incorporates concealed joint covers and strong 1-1/4" ring shank nails to provide long-term holding power. A selection of colors in 24 gauge steel, Kynar® 500 and 32-mil aluminum finish or Kynar 500 is available.
2. **Termination Bar** – A 1" wide and 98-mil thick extruded aluminum bar pre-punched 6" on center which incorporates a sealant ledge to support Lap Sealant and provide increased stability for membrane terminations.
3. Other WeatherBond Metal Edging/Copings suitable for use with roofing system included in the section can be found in the miscellaneous section at the end of the WeatherBond Technical Manual.

2.08 Roof Walkways

Walkways are to be specified at all traffic concentration points (i.e., roof hatches, access doors, rooftop ladders, etc.), and if regular maintenance (once a month or less) is necessary to service rooftop equipment.

1. Walkway Types:

- a. **(Black, Gray, or White) Pressure-Sensitive Molded Walkway Pads** – Molded walkway pads with factory applied Peel & Stick Tape are used to provide protection for areas of EPDM membrane that are exposed to regular rooftop maintenance.
- b. **Interlocking Rubber Pavers**, 24" x 24" x 2" thick rubber paver weighing approximately 24 pounds per unit, 6 pounds per square foot manufactured from recycled rubber, which provides a resilient, shock absorbing, weather resistant surface. Designed primarily for use as a walkway or on terrace areas offering a unique, environmentally sound advantage over concrete pavers. Features include freeze/thaw stability, bi-directional drainage and no breakage concerns. Available in black and terra cotta.

2.09 Other WeatherBond Accessories

Refer to Spec Supplement P-01-11 "Related Products" for additional accessories.

Part III- Execution

Information listed in this specification is provided as a recommendation. Additional requirements dictated by Regulatory Agencies, Building Insurance or Specifiers must be complied with and are considered to be beyond the scope of this specification.

3.01 General

- A. Safety Data Sheets (SDS) must be on location at all times during transportation, storage and application of materials. The contractor shall follow all safety regulations as recommended by OSHA and other agencies having jurisdiction.
- B. Subject to project conditions, it is recommended to begin the application of this roofing system at the highest point of the project area and work to the lowest point to prevent water infiltration. This will include completion of all flashings, terminations and daily seals.
- C. A proper substrate shall be provided by the building owner. This structure shall be sufficient to withstand normal construction loads and live loads.

3.02 Roof Deck/Substrate Criteria

- A. Proper decking shall be provided by the building owner. The building owner or their designated representative must ensure that the building structure is investigated by a registered engineer to assure its ability to withstand the total weight of the roofing system, as well as construction loads and live loads, in accordance with all applicable codes.
- B. Withdrawal resistance tests are strongly suggested to determine the suitability of a roof deck. Refer to Design Reference DR-06-22 "Withdrawal Resistance Criteria"
- C. Defects in the substrate surface should be reported and documented to the specifier, general contractor and building owner for assessment.
- D. On structural concrete decks, when a vapor retarder is not used, gaps in the deck along the perimeter and around penetrations must be sealed along with vertical joints between tilt-up panels, if present, to prevent infiltration of hot humid air and possible moisture contamination resulting from condensation. This is specifically important when adhesive is used to attach the roof insulation.
- E. **For all projects** (new or retrofit), the substrate must be relatively even without noticeable high spots or depressions. Accumulated water, ice or snow must be removed to prevent the absorption of moisture in the new roofing components and roofing system.
- F. Prior to the placement of membrane underlayment, clear the substrate of debris and foreign material that may be harmful to the roofing system. Gaps greater than 1/4" must be filled with an appropriate material.

- G. For direct application over an acceptable roof deck/substrate or when Protective Mat is specified as the membrane underlayment in accordance with the Roof Deck and Substrate Criteria Table, the substrate must be smooth, steel trowel finished (structural concrete), free of debris, protrusions, sharp edges and loose and foreign material. Cracks or voids in the substrate, greater than 1/4", must be filled with an appropriate material.
- H. **On retrofit - recover projects**, cut and remove wet insulation, as identified by the specifier, and fill all voids with new insulation of type specified so it is relatively flush (+/- 1/4") with the existing surface.
 - 1. Entrapment of water between the old and new membrane can damage and deteriorate new insulation/underlayment between the two membranes. **If a vapor retarder or air barrier is not specified**, WeatherBond recommends the existing membrane be perforated to avoid potential moisture accumulation and to allow the detection of moisture to enable the building owner to take corrective action. This can be accomplished by drilling approximately 3/4" diameter holes every 100 square feet in the existing built-up roof or single-ply membrane (excluding PVC membrane).
 - 2. **For existing PVC membranes**, if the membrane is not removed, it must be cut into maximum 10' by 10' sections. All PVC flashings at the perimeter, roof drains and roof penetrations must be removed.
 - 3. When installing this roofing system over an existing **gravel surfaced built-up roof**, **loose gravel must be removed**. Power brooming is recommended by WeatherBond to remove the loose gravel, which may trap moisture. Any uneven areas of the substrate must be leveled to prevent insulation from bridging.
 - 4. On retrofit projects, all existing phenolic insulation must be removed.
 - 5. Refer to table below for other Recover/Retro-fit considerations
- I. The following table identifies the **acceptable roof decks/substrates** and the **minimum underlayment** recommendations for WeatherBond's EPDM Roofing Systems.

Roof Deck & Substrate Criteria

Acceptable Roof Deck/Substrate	EPDM Membrane	
	Fully Adhered	Mechanically Attached
NEW CONSTRUCTION	Fully Adhered	Mechanically Attached
Steel (min. 22 gauge)(1)(2)	Insulation	Insulation
Structural Concrete (min. 3000 psi) or Gypsum	Direct Application	Protective Mat
Plywood (min. 15/32" thick) or Oriented Strand Board (min. 7/16" thick)	Direct Application	Direct Application
Wood Planks (minimum 3/4" thick)	Direct Application	Direct Application
Gypsum and Fibrous Cement	Insulation	Protective Mat
Lightweight Insulating Concrete	Note 3	Direct Application
RETROFIT / NO TEAR-OFF	Fully Adhered	Mechanically Attached
Existing Smooth Surface BUR or Mineral Surface Cap Sheet	Direct Application (4)	Direct Application (4)
Gravel Surfaced BUR (5)	Insulation	Insulation
Coal Tar Pitch (5)(6)	Insulation (9)	Insulation
Modified Bitumen	Direct Application (8)	Direct Application (8)
Existing Single-Ply	Insulation	Direct Application (7)
Sprayed-in-place Urethane	Complete Tear-off Required	Complete Tear-off Required
RETROFIT / TEAR-OFF	Fully Adhered	Mechanically Attached
Existing roof material removed (regardless of deck type)	Insulation	Insulation

Notes:

- (1) Local codes must be consulted regarding thermal barrier requirements.
- (2) Mechanically Attached Systems cannot be specified on steel decks less than 22 gauge or for corrugated steel decks, regardless of gauge.
- (3) The Fully Adhered Roofing System may be specified directly over a new approved cellular or perlite lightweight insulating concrete substrate with a minimum compressive strength of 225 psi. Except when the lightweight insulating concrete is poured over slotted steel decks, pressure relief vents must be specified at a minimum rate of 1 every 2000 square feet. Direct Application is not permitted where the lightweight concrete is poured over an existing roofing material. Refer to **Spec Supplement G-03-22 "Fully Adhered Application Over Lightweight Insulating Concrete"**.
- (4) WeatherBond Black Fully Adhered and Mechanically Attached Systems may be applied directly to the substrate provided asphalt on existing smooth surfaced built-up roof has a softening point above 185°F (85°C). WeatherBond White Fully Adhered Roofing Systems are not recommended for direct application to the substrate due to possible staining of the membrane surface. For direct application over smooth BUR or granule surface BUR or in conjunction with HP Mat make sure substrate is clean and free of roofing cement and fresh asphalt to avoid sheet contamination and staining of white color membrane.
- (5) Loose gravel must be removed to avoid entrapment moisture.
- (6) Existing coal tar could drip back into the building, especially when new insulation does not provide sufficient thermal value to prevent the surface of the coal tar from softening.
- (7) An approved Insulation/underlayment is required over PVC roofing systems of any type.
- (8) Direct application permitted over smooth surfaced modified bitumen. Membrane shall be positioned with length of sheets parallel to modified bitumen field seams. At end laps or other locations where EPDM splices intersect modified bitumen field seams, 6" wide Uncured or Peel & Stick Flashing must be applied over intersections.
- (9) If insulation is specified to be secured to an existing coal tar pitch roof with Flexible DASH Adhesive or hot asphalt, minimum 1.4" thick Polyisocyanurate insulation is the required minimum thickness when WeatherBond Black EPDM is specified. Minimum 1" thick Polyisocyanurate is the required minimum thickness when WeatherBond White EPDM is specified.

J. Vapor Retarder Installation

For Vapor Retarder refer to Spec Supplement G-07-22 "Application Procedures for VapAir Seal 725 TR Temporary Roof Air and Vapor Barrier". Follow the respective vapor retarder manufacturer's recommended installation procedures and the specifier's instructions for the installation of the product specified. When insulation is to be set in adhesive, verify compatibility with WeatherBond when Vapor Retarder by others is specified.

K. Wood Nailers

1. Install wood nailers in locations that have been designated by the specifier and as approved by WeatherBond. Refer to Design Reference DR-08-22 "Wood Nailers and Securement Criteria" for Wood Nailer Criteria.

3.03 Insulation/Underlayment

A. General

1. Roof insulation thickness must be determined by the thermal value required for each project and may be subject to code approval limitations. On projects where a vapor retarder is used, the specifier must calculate insulation thickness to ensure the temperature at the vapor retarder will not fall below the dew point.
2. New construction projects in cold climate regions, the use of vapor retarders or air barriers is strongly recommended to protect insulation from moisture generated during construction.
3. Multiple layers of insulation are recommended with all joints staggered between layers.
4. Do not install more insulation/underlayment than can be covered by membrane in the same day.
5. All insulation boards must be butted together with no gaps greater than 1/4". Gaps greater than 1/4" are not acceptable.
6. Restrictions:
 - a. WeatherBond Roofing Systems cannot be specified in conjunction with Phenolic Insulation.
 - b. Fiberglass insulation cannot be specified with WeatherBond's Fully Adhered and Mechanically Attached Roofing Systems, even if overlaid with additional insulation or membrane underlayment.
 - c. Do not specify perlite boards directly under the EPDM membrane on Fully Adhered or Mechanically Attached Roofing Systems.
 - d. Wood fiberboard manufactured by others is not an acceptable underlayment for use with Fully Adhered Roofing Systems

3.04 Insulation Attachment

A. General

1. Prior to proceeding with insulation securement refer to Tables, Paragraph 1.05, for recommended attachment method and appropriate fastening density.

B. Fully Adhered Roofing Systems

1. **Mechanical Attachment**, insulation fastening density will vary based on insulation type and thickness. Tables in Paragraph 1.05 should be referenced for fastening density and the appropriate WeatherBond detail may be consulted to identify acceptable fastening pattern.
 - a. For code compliance, increased fastening density may be required depending upon project wind speed and wind uplift requirement. Refer to Design Reference DR-05-22 "Insulation Fastening Patterns" for fastening pattern reference.
 - b. When insulation securement is to comply with Factory Mutual (FM) approvals, follow the requirements of the specifier concerning additional securement at the roof perimeter and corners. Also refer to Design Reference DR-05-22 "Insulation Fastening Patterns" for various fastening patterns.
 - c. On Reroof/No Tear off projects with a maximum roof height of 40', any WeatherBond Insulation (i.e., 1/2" XFP HD, Recovery Board, Polyisocyanurate less than 1-1/2" thick) may be secured at the minimum rate of 11 Fasteners per 4' x 8' board (5 Fasteners per 4' x 4' board).

- d. Oriented strand board (OSB) when specified as the membrane underlayment, must be Mechanically Attached to the deck at the rate of 17 fasteners per 4 x 8 board in accordance with WeatherBond Details. If OSB is to be used in conjunction with WeatherBond urethane based adhesive, an OSB/Polyisocyanurate composite board is recommended. When positioning OSB it shall not be butted allow 1/8" gaps between boards to prevent cupping.
2. **Adhesive attachment**, WeatherBond Urethane Adhesive Bead applied (Flexible DASH or Olybond) may be used. CAUTION: Apply adhesive bead so that the distance from the edge of the board does not exceed half the bead spacing (i.e. within 6" of bead spacing of 12" O.C.).

CAUTION: Do not apply urethane adhesives directly to un-weathered asphalt, (new or residual)

CAUTION: Especially in cold regions on tear-off projects or new construction gaps between horizontal and vertical surfaces of the roof area as well as gaps around penetrations must be sealed to prevent interior warm air from infiltrating and condensing within the roofing assembly. Condensing moisture could weaken bottom insulation facer and eventually result in dislodgement or loose boards when adhesive is used.

- a. On FM Global insured projects, consult FM Global's local representative concerning the use of adhesive to attach insulation to steel decks.
- b. Check to ensure the substrate is dry. Adhesive cannot be applied to a wet or damp surface.
- c. Apply Adhesive over the dry substrate area at the coverage rates indicated in Spec Supplement G-02-22 "Adhesive Application/Coverage Rate".
- d. Allow the adhesive to rise up approximately 1/8" and develop strings prior to setting insulation boards into adhesive.

NOTE: String-time is measured by touching the adhesive with a splice wipe and looking for development of "strings" of adhesive as you pull the splice wipe out of the adhesive. With Flexible DASH Adhesive, string time is generally around 1-1/2 – 2 minutes after application at room temperature.

- e. **Walk the boards into the adhesive and roll using the 30" wide, 100 – 150 pound weighted steel roller** to ensure full embedment. Optimal set up time should be approximately 5 to 10 minutes.

CAUTION: Walking on the boards immediately after placement in adhesive can cause slippage/movement until the adhesive has started to set up.

On roofs with a slope greater than 1/2" in 12", begin adhering insulation at the low point and work upward to avoid slippage.

A person should be designated to walk/roll in all boards and trim/slit or apply weight as needed to ensure adequate securement.

- f. Refer to Spec Supplement G-02-22 "Adhesive Application/Coverage Rate" for coverage rates.

3. **Alternate attachment method**, the specifier may select an alternate insulation attachment that incorporates a solid mopping of the insulation with hot asphalt (ASTM D312, Type III or IV).

- a. Extruded or Expanded Polystyrene insulation are not acceptable when this alternate attachment method is specified.
- b. The existing gravel surfaced built-up roof must be scraped to remove all loose gravel. Large blisters that may prevent continuous embedment of insulation must be repaired. The surface of the substrate must also be dry and clear of foreign material.
- c. On coal tar pitch, when deemed compatible by the specifier, minimum 1.5" Polyisocyanurate is the required membrane underlayment when using WeatherBond Black membrane. If WeatherBond White membrane is used, minimum 1" thick Polyisocyanurate is required.
- d. For successful attachment, proper asphalt temperatures must be maintained and the specifier's requirements concerning the installation of a base sheet (where required) and quantity of hot asphalt must be followed.
- e. The maximum insulation board size shall not exceed 4' X 4'. Trim insulation boards around crickets and saddles to ensure continuous embedment.

- f. Care must be exercised to prevent contamination of the top surface of the insulation. Asphalt oozing through insulation joints must be wiped from the surface. Contact with fresh asphalt can result in discoloration of the WeatherBond White membrane.
- g. Use of a grid nailer subdividing the roof in individual sections of 2400 square feet is highly recommended but not required.
- h. The wood nailers are installed relatively flush with the insulation surface and the membrane is to be fastened with seam fastening plates and WeatherBond HPW fasteners on 12" o.c. For wood nailer installation, refer to Design Reference DR-08-22 "Wood Nailers and Securement Criteria".

C. Mechanically Attached Roofing System

1. **WeatherBond Fasteners and Fastening Plates are recommended for insulation securement.** Refer to Insulation Fastening Criteria Table in Paragraph 2.05, for appropriate fastener and deck penetration. The fastener can be used either 2" diameter WeatherBond Seam Fastening Plates or 3" diameter WeatherBond Insulation Fastening plate.
2. **Any WeatherBond approved insulation or cover board shall be Mechanically Attached to the roof deck at the minimum rate of 1.25 fasteners and plate per every 8 square feet** (5 fasteners in a 4 x 8 board) for warranties up to 15 years.

CAUTION: WeatherBond Polyisocyanurate Insulation with a thickness less than 1.5" installed over an existing roofing membrane without a tear-off must be Mechanically Attached to the roof deck with a minimum of 1 fastener and plate for every 4 square feet or less of insulation.

3. Use of DensDeck, DensDeck Prime and DensDeck StormX Prime should be limited to assemblies with slopes greater than 2" per foot to ensure compliance with external fire codes, care shall be exercised to ensure polymer plates are fully seated.

3.05 Membrane Placement and Securement

A. General

1. **Ensure** that water does not flow beneath any completed sections of the membrane system by completing all flashings, terminations and daily seals by the end of each workday.
2. **Sweep** all loose debris from the substrate.
3. If aesthetics are of concern when WeatherBond White EPDM is to be used, protection should be specified to avoid discoloration of the white membrane surface resulting from adhesive residue.
4. Adjoining sheets of EPDM membrane are spliced together using P&S Seam Tape and Primer.
5. In addition to the primary membrane securement (Bonding for Fully Adhered and Fastening for Mechanically Attached Assemblies), Additional membrane securement is required at the perimeter of each roof level, roof section, curb, skylight, interior wall, penthouse, etc., at any inside angle change where slope or combined slopes exceed 2" in one horizontal foot, and at other penetrations in accordance with the applicable WeatherBond details. Refer to Paragraph G for additional membrane securement.

B. Membrane Placement

EPDM membrane with factory-applied tape is available in various widths. Only 8' and 10' wide sheets are available in a double pack (2 sheets per roll). Prior to unrolling sheets ensure the tape side is properly located so that seams are properly shingled down slope. (Pre-applied P&S Seam Tape should always be facing downwards once the sheet is unrolled).

1. **Position** EPDM membrane over the acceptable substrate without stretching. For Mechanically Attached assemblies, ensure the proper number of perimeter sheets are properly positioned along the perimeter of the roof. And field sheets are positioned perpendicular to the steel deck flutes.
2. **Allow** the membrane to relax approximately 1/2 hour prior to splicing, bonding (Fully Adhered Systems) or

fastening (Mechanically Attached systems).

3. **Place** joining membrane sheets in the same manner, overlapping edges appropriately to provide for the minimum splice width. It is recommended all splices be shingled to avoid bucking of water.

C. **Membrane Securement/Bonding – Fully Adhered Roofing System (LC-60, x-23 Low-VOC Bonding Adhesive or Aqua Base 120)**

1. **Adhere** EPDM membrane to an acceptable substrate with WeatherBond EPDM bonding adhesive. Comply with Labels, Safety Data Sheet (SDS) and Technical Data Bulletins for installation procedures and use. Adhesive must be applied to both the membrane and the surface to which it is being bonded.
2. On projects at high altitudes (6,000' and above), rapid flash off (drying) of EPDM Adhesive and Primers will occur due to low atmospheric pressure.
3. **Fold** membrane sheet back so half of the underside of the sheet is exposed. Sheet fold should be smooth without wrinkles or buckles
4. **Stir** EPDM Adhesive thoroughly scraping the sides and the bottom of the can (minimum 5 minutes stirring is recommended). Bonding surfaces must be dry and clean.

CAUTION: If aesthetics are of concern when WeatherBond White EPDM membrane is used, protect the white surface next to the edges of the folded membrane sheet so Adhesive will not discolor the white surface. Do not place Adhesive containers or their lids directly on the white surface of the WeatherBond White EPDM membrane.

5. **Apply Bonding** Adhesive evenly, without globs or puddles with a plastic core medium nap paint roller. A 9" roller will easily fit into the 5-gallon containers.

Apply Adhesive to both the membrane sheet and the substrate to achieve continuous coating of both surfaces at a coverage rate of approximately 120 square feet per gallon per one surface (membrane or substrate) or approximately 60 square feet per gallon per finished surface (includes coverage on both membrane and substrate). **Depending on adhesive used and the substrate type adhesive coverage rate will vary.** Refer to Technical Data Bulletin for the appropriate adhesive for the proper coverage rate.

A mechanical roller dispenser or a mechanical sprayer can be used to apply Bonding Adhesive when the continuous coating and coverage rate noted above are maintained. When used, **the adhesive must be rolled after applying** with a plastic core medium nap paint roller to provide continuous coverage.

CAUTION: Due to solvent flash off, condensation may form on freshly applied Adhesive when the ambient temperature is near the dew point. If condensation develops, possible surface contamination may occur and the application of Adhesive must be discontinued. Allow the surface to dry and apply a thin freshener coat at the coverage rate, which is approximately half of the coverage rate stated above to the previously coated surface when conditions allow for continuing.

6. **Allow** adhesive to flash-off until it is tacky but will not string or stick to a dry finger touch.
7. **Roll** the coated membrane into the coated substrate while avoiding wrinkles.
8. **Brush** down the bonded half of the membrane sheet, immediately after rolling the membrane sheet into the adhesive, **with a soft bristle push broom** to achieve maximum contact.
9. **Fold** back the unbonded half of the membrane sheet and repeat the bonding procedure.

D. **Membrane Securement / Bonding - Adhered Roofing Systems (CAV-GRIP III)**

1. **Adhere** EPDM membrane to an acceptable substrate with CAV-GRIP III Bonding Adhesive. Comply with Labels, Safety Data Sheet (SDS) and Product Data Sheets for installation procedures and use. Contact type bonding adhesive must be applied to both the membrane and the surface to which it is being bonded.
2. On projects at high altitudes (6,000' and above), rapid flash-off (drying) of Bonding Adhesive and Primers will occur due to low atmospheric pressure.
3. **Fold** membrane sheet back so approximately half of the underside of the sheet is exposed. Sheet fold should be smooth without wrinkles or buckles.
4. **Connect CAV-GRIP III Cylinder** with hose and spray gun. Bonding surfaces must be dry and clean.

CAUTION: If aesthetics are of concern when White EPDM membrane is used, protect the white surface next to the edges of the folded membrane sheet so Bonding Adhesive will not discolor the white surface. Do not place CAV-GRIP III Cylinders directly on the white surface of the White EPDM membrane.

5. **Spray apply CAV-GRIP III** Bonding Adhesive evenly to both the membrane and substrate with a minimum 2” overlap to ensure 100% coverage. Avoid heavy areas or puddles that can skin over, trap solvent and create a blister. Refer to Product Data Sheets for the appropriate adhesive for the proper coverage rate.

CAUTION: Solvent flash-off can lower surface temperature below the dew point causing moisture to form on the adhesive. Slide your hand across the flashed-off adhesive on the insulation or cover board to ensure moisture has evaporated and the adhesive surface is dry and tacky prior to installing the membrane.

6. **Allow** adhesive to flash-off until it is tacky but will not string or transfer to a dry finger touch.
7. **Roll** the coated membrane into the coated substrate while avoiding wrinkles.
8. **Brush** down the bonded half of the membrane sheet, immediately after rolling the membrane sheet into the adhesive, **with a soft bristle push broom**.
9. **Roll the membrane with a 150 lb weighted segmented steel roller after brooming to achieve maximum contact.**
10. **Fold** back the unbonded half of the membrane sheet and repeat the bonding procedure.

E. Membrane Securement/Mechanically Attached Roofing System (Fastening)

1. EPDM membrane shall be mechanically attached to the structural deck with specified WeatherBond Fasteners and designated Plates or Bars, for fastening densities and numbers of perimeter sheets refer to Tables, Paragraph 1.05.

2. Membrane Fastening Selection Table

Membrane Fastener Selection

Deck Type	WeatherBond Fasteners*	WeatherBond Plate
Steel or Lightweight Insulating Concrete over Steel	HPW	HPW Polymer or Seam Fastening Plates
	HPW-XL	HPW-XL Polymer
Structural Concrete, rated 3,000 psi or greater	CD-10	HPW Polymer or Seam Fastening Plates
	MP 14-10	HPW Polymer or Seam Fastening Plates
Wood Plank, min. 15/32" thick Plywood or min. 7/16" OSB	HPW	HPW Polymer or Seam Fastening Plates
Cementitious Wood Fiber	Polymer Gyptec	Gyptec Plates – 2” Dia.
Gypsum	Polymer Gyptec	Gyptec Plates – 2” Dia.

Refer to Tables in Paragraph 1.05 for fastening densities and number of perimeter sheets.

*Determine proper fastener length for deck penetration, refer to Table 2.05B.

3. On steel decks, membrane shall be positioned with seams perpendicular to the steel deck flutes. This allows the external forces on the roof assembly to be distributed between multiple steel deck panels. Refer to Design Reference DR-06-22 “Withdrawal Resistance Criteria”.
4. When mechanical securement is not provided in some of the WeatherBond Common Details (i.e., pipes and pourable sealer pockets), additional Seam Fastening Plates must be used for membrane securement. The plates must be positioned a maximum of 12" away from the penetration, spaced a maximum of 12" on center and flashed in accordance with the applicable WeatherBond Detail.

5. Perimeter Sheets

The number of perimeter sheets and fastener spacing is dependent on the building height and wind zone location as outlined in Tables in Paragraph 1.05.

The roof perimeter is defined as all edges of each roof section (i.e., parapets, building expansion joints at adjoining walls, penthouse walls, etc.). When multi-level roofs meet at a common wall, the adjacent edge of the upper roof is treated as a roof perimeter if the difference in height is greater than 3'. Perimeter sheets are not required at the base of the wall at the lower level.

NOTE: Expansion joints, control joints and fire walls in the field of the roof or roof ridges with slopes less than 3" to the horizontal foot are not considered as part of the roof perimeter.

Perimeter sheets can be formed by using individual 5' or 6.5' wide sheets or by sub-dividing 8' or 10' wide field sheet using RPS strip or row of seam fastening plates as described below.

a. **Individual Perimeter Sheets (5' or 6.5')**

Position the membrane along the perimeter of the roof over the acceptable insulation/underlayment. The perimeter membrane width from line of securement to line of securement should be approximately 4'6" to 6'0" wide.

b. **RPS (Reinforced Perimeter Strip) Method**

- 1) When **field sheets are positioned parallel to a roof perimeter, 9" wide Peel & Stick RPS** (with 3" wide tape each side) shall be placed approximately down the center of the 8' or 10' wide field membrane sheets. When a RPS divides a field sheet in half, two perimeter sheets are created.
- 2) When a 8' or 10' wide reinforced **EPDM membrane sheet extends perpendicular to the edge of the roof**, install **9" wide Peel & Stick RPS** beneath the EPDM membrane sheet approximately of 3'-6" for the 8' field sheet to approximately of 4' -0" for the 10' field sheet from the edge of the roof. When multiple perimeter sheets are required, additional RPS may be positioned approximately 3'-6" to 4'-0" from the previous RPS to create additional perimeter sheets.

CAUTION: 6" wide Peel & Stick RPS is only available with 3" wide P&S Seam Tape on one side and therefore cannot be used to form perimeter sheets.

- 3) Refer to Applicable WeatherBond Details for installation

c. **Fastening Plates Method**

When field sheets extend to the edge of the roof, approved fastening plates can be installed through the reinforced membrane 3'-6" to 4'-6" from the roof edge which will be flashed with 6" wide Peel & Stick Cured Cover Strip. When field sheets are positioned parallel to the roof edge, fastening through the membrane along the centerline creates two perimeter sheets. When multiple perimeter sheets are required, additional fastening plates shall be positioned 3'-6" to 4'-6" from the previously installed fastening plates. Refer to applicable WeatherBond Details for installation.

d. **Building with Special Conditions:**

Air pressurized buildings, canopies and buildings with large openings where the total wall openings exceed 10% of the total wall area on which the openings are located (such as airport hangers, warehouses and large maintenance facilities) will typically require additional perimeter membrane securement, an increased fastening density or other enhancement.

e. **Building with large openings**

When any wall contains major openings with a combined area which exceeds 10% of the total wall area on which the openings are located, either four 4-1/2' wide to two 10' wide reinforced EPDM membrane sheets (centered over the opening) must be specified as shown.

- 1) 9" wide Peel & Stick RPS (Reinforced Perimeter Strip) shall be specified in conjunction with the 10' wide membrane sheets.
- 2) The 9" wide Peel & Stick RPS is to be positioned beneath the 10' wide membrane sheet along the centerline and shall be secured with Polymer Seam Plates (required for steel decks) or Seam Fastening Plates. All fasteners and plates shall be spaced at the rate required at the roof perimeter as shown on the membrane securement charts on the previous pages.

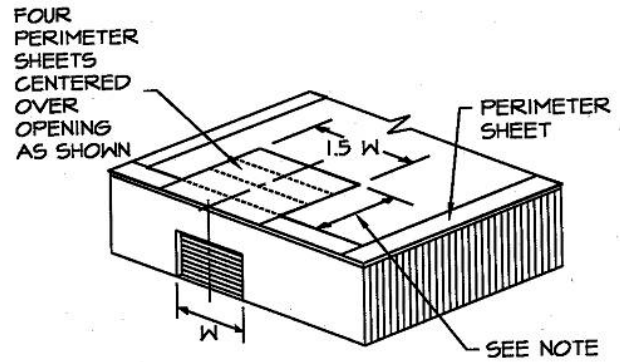

- 3) As an option to the above perimeter securement, a fully adhered membrane section may be used in lieu of the mechanically attached membrane at large openings in accordance with the WeatherBond Specification for the WeatherBond (black and white) Fully Adhered Roofing System.

NOTE: Depth of perimeter area, noted above, shall not be less than 2.5 times the width of the opening.

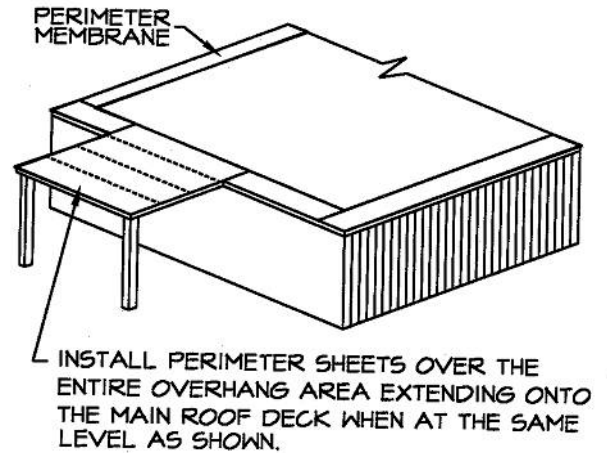

f. **Buildings with overhangs**

The membrane must be specified with securement 3-1/2' to 4-1/2' over the entire overhang area extending onto the main roof deck a minimum of 3 1/2' when at the same level.

- 1) This can be achieved utilizing individual 4-1/2' perimeter membrane sheets or 10' wide membrane sheets in conjunction with 9" wide Peel & Stick RPS as described above.
- 2) As an option, a fully adhered membrane section may be used in lieu of the mechanically attached membrane at building overhangs in accordance with the WeatherBond Specification for the WeatherBond (black and white) Fully Adhered Roofing System.

6. **Field Membranes**

- a. **Position** field membrane sheets adjacent to perimeter membrane to allow a minimum 6" overlap, 3" from the center of the plate or bar in front and back.
- b. **Secure the field and perimeter membrane sheets** along the pre-printed blue line approximately 3" from the edge of the membrane sheet at the approved fastening density with the required WeatherBond Fastener and WeatherBond Seam Plates or Bars. Refer to "Membrane Fastener Selection" Table in Paragraph 3.05 for further information.

Correct fastener placement must conform to the following:

- 1) The **minimum** distance between the bottom membrane edge and the nearest edge of the fastening plate or bar must be **2"**.
- 2) The **minimum** distance between the overlapping membrane edge and the nearest edge of the fastening plate or bar must be **2"**.

- c. On new construction projects, where direct application of the membrane is specified over Protection Mat over lightweight insulating concrete, standard 2" diameter Seam Fastening Plates must be used since the Polymer Seam Plates will not properly seat. Sure-Tite Fastening Bars may also be utilized.
- d. **Position** adjoining membrane sheets to allow a minimum overlap of 6" where Fastening Plates are located (along length of the membrane); at the same time overlap end roll sections (width of the membrane) a minimum of 3".
- e. Work shall progress across the roof with a minimum 6" overlap provided at the previously secured sheet edge. The opposite length of the sheet must be secured with approved Fastening Plates or bars and overlapped accordingly.

F. Membrane Splicing

1. General

a. Fully Adhered Roofing Systems

- 1) Tape splices must be a minimum of 2-1/2" wide using 3" wide P&S Seam

b. Projects with 90 mil membranes

- 1) WeatherBond (Black) Membrane

Splices may be a minimum of 2-1/2" wide using 3" wide Factory-applied P&S Seam Tape. In addition the entire field splice must be overlaid with a continuous 6" wide Peel & Stick Cured Cover Strip.

OR

Splices may be a minimum of 5-1/2" wide using 6" **Factory-Applied P&S Seam Tape**. In addition and in lieu of the continuous cover strip, 'T'-Joints must be flashed with a bead of lap sealant and a double layer of Peel & Stick flashing. The first layer shall be 6"x6" Peel & Stick uncured EPDM flashing, followed by second layer of 12"x12" Peel & Stick Cured Cover strip.

- 2) WeatherBond (White) Membrane

Splices must be a minimum of 5 1/2" wide using 6" P&S Seam Tape. All Splice Intersections must be flashed with a bead of lap sealant and two layers of Peel & Stick uncured EPDM flashing. The bottom layer shall be 6"x6" covered with 12"x12" top layer. Both layers shall be centered over the splice intersection and sealed with WeatherBond (white) Lap Sealant per the applicable WeatherBond Detail.

Note: WeatherBond (white) Peel & Stick Uncured Flashing is available only in rolls of 6", 9" or 12" wide. Material used for Overlayment shall be cut from the appropriate roll

c. WeatherBond Reinforced Mechanically Attached Roofing Systems

Side laps where fastening plates are placed shall be spliced using 6" wide Factory-Applied P&S Seam Tape or field applied P&S Seam Tape. The splice tape shall be centered over the plates to extend approximately 2" on each side. P&S Seam Tape must extend approximately 1/8" beyond the edge of the overlapping membrane. Center a single layer of 6"x6" Peel & Stick uncured EPDM flashing at all splice intersections.

End Laps, shall be spliced using either 3" or 6" wide P&S Seam Tape resulting in a minimum splice of 2 1/2" or 5 1/2" wide.

- 2. For splicing procedures, cautions and warnings refer to Spec Supplement E-02-22 "Membrane Splicing and Splice Repairs" for information.

G. Additional Membrane Securement

Securement must be provided at the perimeter of each roof level, roof section, expansion joint, curb flashing, skylight, interior wall, penthouse, etc., at any inside angle change where slope exceeds 2" in one horizontal foot, **and at other penetrations** in accordance with WeatherBond's details and securement options as listed below.

Securement may be achieved as follows:

1. **Peel & Stick RPS (Reinforced Perimeter Strip)**

Peel & Stick RPS is a 6" wide strip of reinforced EPDM membrane with factory-applied 3" wide P&S Seam Tape and is installed in conjunction with WeatherBond EPDM Fasteners and 2" diameter Seam Fastening Plates spaced a maximum of 12" on center below the EPDM deck membrane (Polymer Seam Plates, Polymer Batten Strips or ST Fastening Bars are required for Mechanically Attached Roofing Systems over steel decks). The securement strip can be installed horizontally or vertically at the base of walls or penetrations.

a. Loose lay the 6" wide Peel & Stick RPS along parapet walls and fasten with Seam Fastening Plates and the appropriate WeatherBond fastener to the roof deck or into the parapet wall. Spacing of the Seam Fastening Plates shall be a maximum of 12" on center.

1) For horizontal attachment, the reinforced strip must be positioned a minimum of 1/8" to a maximum of 6" away from the angle change with pressure sensitive side facing away from the parapet and towards the roof plane.

2) For vertical attachment, the reinforced strip must be attached to the vertical wall with pressure sensitive side extending onto the roof surface.

b. Adjoining sections of the reinforced strip need not be overlapped; however, gaps between adjoining sections must not exceed 1".

CAUTION: When RPS is used for membrane securement along metal edgings, refer to the appropriate detail for applicable installation criteria. For some metal edge details, adjoining sections of the reinforced strip must be overlapped and spliced.

c. **When using Peel & Stick RPS, clean the underside of the membrane with WeatherBond Primer** and allow proper drying prior to removing the release film from the RPS.

CAUTION: On fully adhered systems discontinue bonding adhesive application on the underside of the membrane in area of the sheet where contact with the Peel & Stick RPS is to occur. Contact between Peel & Stick RPS and membrane coated with adhesive can result in poor peel and shear values.

2. **Seam Fastening Plates**

When the use of Peel & Stick RPS is not feasible (at smaller curbs or skylights) 2" diameter Seam Fastening Plates may be used.

a. Seam Fastening Plates may be installed horizontally into the structural deck or into walls or curbs.

b. Securement of the EPDM membrane with the approved WeatherBond Fasteners and Seam Fastening Plates must be a maximum of 12" on center starting 6" minimum to 9" maximum from inside and outside corners.

c. If horizontal wood nailers are provided, secure the Seam Fastening Plates to the wood nailer with WeatherBond HPW Fasteners. Nails (i.e. ringshank, roofing, etc.) are not acceptable for securement.

d. After securing the Seam Fastening Plates, flash in accordance with the appropriate WeatherBond Detail.

3.06 Flashings

A. **General Considerations**

1. All vertical field splices at the base of a wall or curb must be overlaid with Peel & Stick "T" Joint Covers, a 6" by 6" section (with rounded corners) of WeatherBond (black and white) Peel & Stick Uncured EPDM Flashing centered over the field splice.

2. **Peel & Stick Uncured EPDM Flashing** must be limited to the overlayment of vertical seams (as required at angle changes), or to flash inside/outside corners, vent pipes, scuppers and other unusually shaped penetrations where the use of Pre-molded Pipe Seals, cured EPDM membrane or Peel & Stick Cured Cover Strip is not practical.

NOTE: When using Peel & Stick products in colder temperatures, use a heat gun to warm the product. Apply heat to the EPDM flashing side of the product. Do not apply heat directly to the pre-applied adhesive. The Peel & Stick Flashing must be applied immediately after primer flashes off. Refer to “Membrane Splicing with P&S Seam Tape” for application procedures in colder temperatures.

3. When using **Peel & Stick Cured Cover Strip** to overlay Seam Fastening Plates or metal edging, etc., **Multipurpose Primer or LOW VOC Primer** must be used to clean the membrane and metal flanges.
4. When using Solvent-Free EPDM Bonding Adhesive refer to the Technical Data Bulletin for additional installation information.

B. Walls, Parapets, Curbs, Skylights, etc.

1. Use continuous deck membrane with Peel & Stick RPS (Reinforced Perimeter Strip) or Seam Fastening Plates along the angle change.
 - a. When using Peel & Stick RPS, refer to Paragraph 3.05 G, Additional Membrane Securement, for attachment criteria.
 - b. When Seam Fastening Plates are used to secure continuous deck membrane, use minimum 6" wide Peel & Stick Cured Cover Strip to overlay fasteners and plates.
2. When the use of continuous deck membrane for wall flashing is not feasible, a separate piece of cured EPDM membrane may be used.
3. Adhere flashing to the wall and terminate in accordance with the applicable WeatherBond Detail.
4. Use a “T” Joint Cover or 6" by 6" Peel & Stick Uncured Flashing with rounded corners to overlay vertical splices as shown on the applicable WeatherBond Detail.
5. Refer to applicable WeatherBond Details for various corner flashing options.

C. Flashing of other Penetrations, refer to Spec Supplement G-04-22 for Flashing Considerations and the applicable WeatherBond detail for specific requirements.

3.07 Roof Walkways

Walkways are to be specified at all traffic concentration points (i.e., roof hatches, access doors, rooftop ladders, etc.), and if regular maintenance (once a month or more) is necessary to service rooftop equipment. Refer to Spec Supplement G-05-22 “Roof Walkway Installations.”

3.08 Daily Seal

On phased roofing, when the completion of flashings and terminations is not possible by the end of each workday, provisions must be taken to temporarily close the membrane to prevent water infiltration. Refer to Spec Supplement G-06-22 “Daily Seal & Clean Up”.

3.09 Clean Up

For daily tie-off or cleaning procedures refer to Spec Supplement, G-06-22 “Daily Seal / Clean Up” in the WeatherBond Technical Manual.

A. General

1. Termination bars and surface mounted reglets must be specified to be installed directly to the wall surface.
2. WeatherBond recommends WeatherBond Metal Edging/Coping, Termination Bar or Drip Edge for membrane termination.

NOTE: Refer to Tables in Section 1.05 for specific metal edge requirements for projects with Total System Warranties or those with extended peak gust wind speed coverage greater than 80 miles per hour.

3. Metal work by others, when specified, must be fastened to prevent the metal from pulling free or buckling and sealed to prevent moisture from entering the roofing system or building.

4. **On retrofit projects**, existing counter flashing, edging, expansion joint covers, copings, etc., shall not be reused unless investigated by the specifier to determine its compliance to WeatherBond's current details.

Copyright 2024 WeatherBond
WeatherBond is a Trademark of WeatherBond
Insulfoam, InsulLam, R-Tech by Insulfoam
Foamular is a Trademark of Owens Corning
Styrofoam is a Trademark of Dow Chemical Company
OlyBond is a Trademark of OMG, Inc.



WEATHERBOND ROOFING SYSTEMS

WeatherBond EPDM Roofing Systems Fully Adhered and Mechanically Attached

Installation Details

TABLE OF CONTENTS

January 2024

Mechanically Attached

Membrane Securement – Option 1	WBRMA-2.0A
Membrane Securement with Peel & Stick RPS – Option 2	WBRMA-2.0B
Mechanically Attached EPDM Securement – Option 3	WBRMA-2.0C
EPDM Membrane Splice	WBRMA-2.1
P&S Seam Tape Splice Intersection	WBRMA-2.2
End Lap Splice	WBRMA-2.3
Roof Drain with Sump	WBRMA-6.0
Peel & Stick Pipe Seal.....	WBRMA-8.1
Peel & Stick Pipe Seal with 20” Peel & Stick Cured Flashing.....	WBRMA-8.1A
Field Fabricated Pipe Seal	WBRMA-8.2
Ridge Membrane Attachment	WBRMA-22.0

Metal Edges and Gravel Stops

WeatherBond Drip Edge Fascia	WBRC-1.1A
Metal Bar Edge Termination.....	WBRC-1.3

Membrane Splices

EPDM Membrane Splices	WBRC-2.1A
EPDM Membrane Splices- Projects with 90-mil Membrane	WBRC-2.1B
P&S Seam Tape Splice Intersection	WBRC-2.2
EPDM Membrane Splice Intersection (90-mil Membrane)	WBRC-2.2A
EPDM Membrane Splices at Angle Change.....	WBRC-2.3

Expansion Joints

Deck-to-Deck Curbed Expansion Joint.....	WBRC-3A.1
Deck-to-Deck Expansion Joint	WBRC-3.1
Deck-to-Wall Expansion Joint	WBRC-3.2
Shear/Expansion Cover	WBRC-3.3

Curb Flashing

Curb Flashing.....	WBRC-5.1
Peel & Stick Curb Wrap.....	WBRC-5.2
Self-Flashing Curb.....	WBRC-5.3
New Self-Flashing Metal Curb.....	WBRC-5.4
Self-Flashing Curb, Roof Hatch, or Skylight	WBRC-5.5

Drains

Roof Drain – Reinforced Field Sheet with Sump Exceeding 3” Per Foot.....	WBRC-6.2
Add-on Drain	WBRC-6.3
Insert Drain.....	WBRC-6.4
Insert Drain Through Deck	WBRC-6.5

Pipe Flashing

Pre-Molded Peel & Stick Pipe Seal	WBRC-8.1A
---	-----------

Pre-Molded Peel & Stick Pipe Seal with 90-mil Membrane	WBRC-8.1B
Field Fabricated Pipe Seal	WBRC-8.2
Flexible Penetration.....	WBRC-8.3
Field Fabricated Hot Stack	WBRC-8.5

Terminations

Membrane Terminations, Page 1 of 3	WBRC-9.0A
Membrane Terminations, Page 2 of 3	WBRC-9.0B
Membrane Terminations, Page 3 of 3	WBRC-9.0C

Parapet / Curb Flashing

Parapet/Curb with Peel & Stick RPS	WBRC-12.1
Parapet/Curb with Separate Membrane Flashing	WBRC-12.2

Tie-Ins

Built-Up Roofing Tie-In over Steel Roof Deck	WBRC-13.1
Built-Up Roofing Tie-In over Concrete Roof Deck	WBRC-13.2
Tie-In to Existing EPDM Membrane	WBRC-13.3
EPDM Tie-In Over Concrete Deck	WBRC-13.4
Tie-In with Shingled Roof	WBRC-13.5
Tie-In Between New WeatherBond Fully Adhered & Ballasted Roof	WBRC-13.6

Inside/Outside Corners

Inside Corner with RPS (Option 1)	WBRC-15.1
Inside Corner with RPS (Option 2)	WBRC-15.2
Inside Corner with Continuous EPDM Wall Flashing.....	WBRC-15.3
Inside Corner with Separate EPDM Wall Flashing	WBRC-15.4A
Inside Corner Flashing for Projects with 90-mil Membrane	WBRC-15.4B
Outside Corner with Pre-Cut Peel & Stick Flashing	WBRC-15.5
Outside Corner with Peel & Stick Uncured Flashing (Option 1)	WBRC-15.6
Outside Corner with Peel & Stick Uncured Flashing (Option 2)	WBRC-15.7
Outside Corner Flashing for Projects with 90-mil Membrane	WBRC-15.8

Sealant Pocket

Peel & Stick Pourable Sealer Pocket	WBRC-16.1
Field Fabricated Pourable Sealer Pocket.....	WBRC-16.2
Extended Pourable Sealer Pocket	WBRC-16.3

Through-Wall Scupper

Metal Scupper at Deck	WBRC-18.1
-----------------------------	-----------

Lightning Rod

Lightning Rod at Parapet (Vertical Attachment)	WBRC-20.1
Lightning Rod at Deck Level with Pourable Sealer	WBRC-20.2

Valley

Valley	WBRC-22.0
--------------	-----------

Sleeper

Sleeper	WBRC-24.0
---------------	-----------

Penetration

I-Beam Penetration	WBRC-30.0
--------------------------	-----------

GUIDELINES FOR ROOF PERIMETER ZONES FOR MECHANICALLY ATTACHED ROOF SYSTEM

SPLIT LEVEL ROOFS

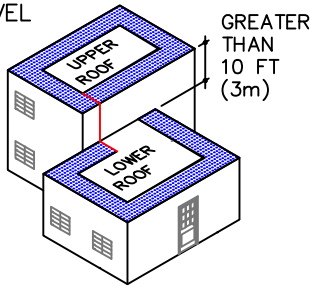

SPLIT LEVEL ROOFS

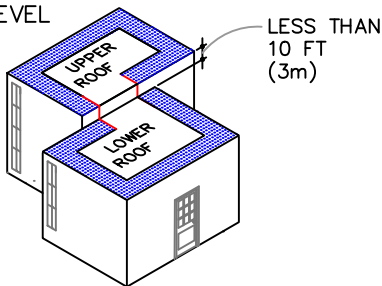

CANOPY ROOF

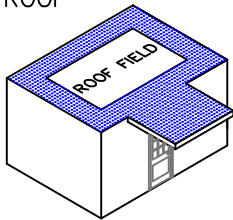

INSTALL PERIMETER SHEETS OVER THE ENTIRE OVERHANG (PROJECTION ROOF) AREA, EXTENDING ONTO THE MAIN ROOF DECK WHEN AT THE SAME LEVEL AS SHOWN.

LARGE OPENINGS OR LOADING DOCKS

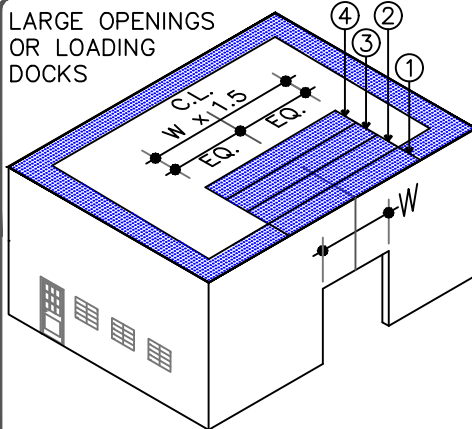

FOUR PERIMETER SHEETS CENTERED OVER LARGE OPENINGS

PERIMETER ZONES

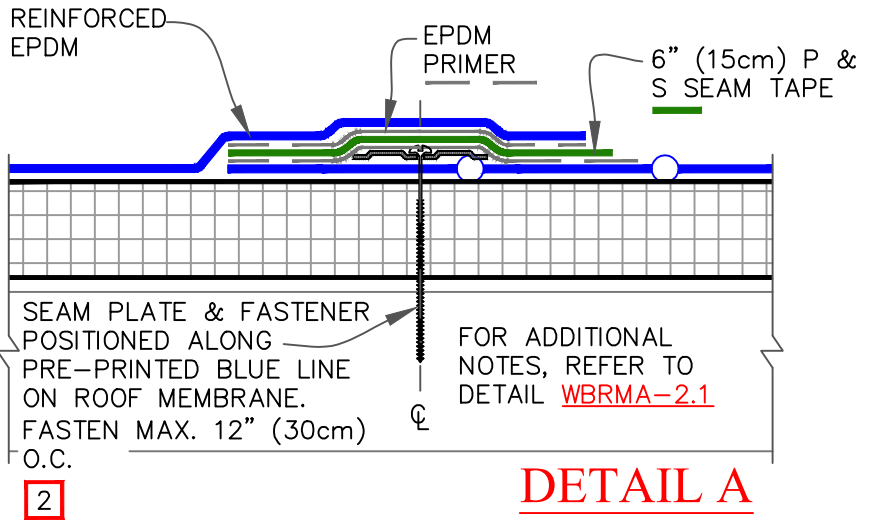
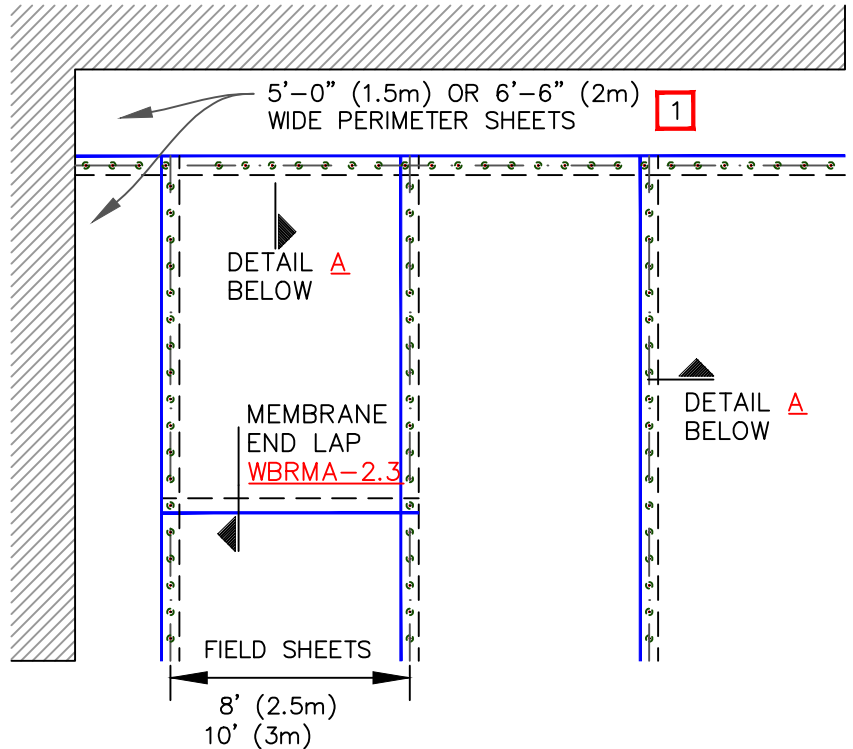

NOTES:

1. REFER TO WEATHERBOND SPECIFICATIONS FOR REQUIRED NUMBER OF PERIMETER SHEETS, SHEET WIDTH AND MEMBRANE FASTENING DENSITY.
2. HPWX FASTENERS AND POLYMER SEAM PLATES ARE REQUIRED OVER STEEL DECKS.

GUIDELINES FOR ROOF PERIMETER ZONES FOR MECHANICALLY ATTACHED ROOF SYSTEM

SPLIT LEVEL ROOFS

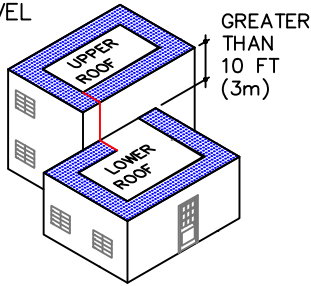

SPLIT LEVEL ROOFS

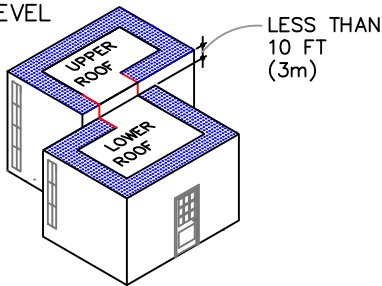

CANOPY ROOF

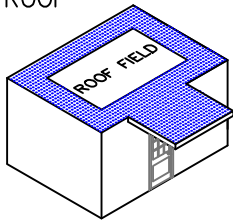

INSTALL PERIMETER SHEETS OVER THE ENTIRE OVERHANG (PROJECTION ROOF) AREA, EXTENDING ONTO THE MAIN ROOF DECK WHEN AT THE SAME LEVEL AS SHOWN.

LARGE OPENINGS OR LOADING DOCKS

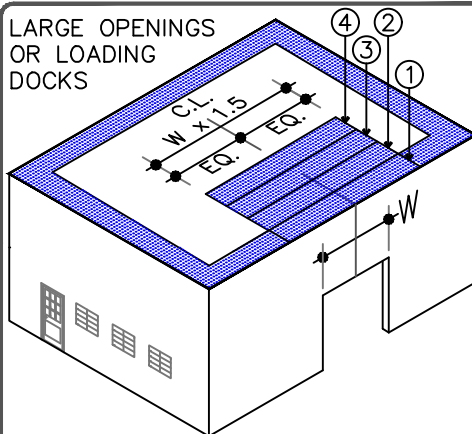

FOUR PERIMETER SHEETS CENTERED OVER LARGE OPENINGS

PERIMETER ZONES

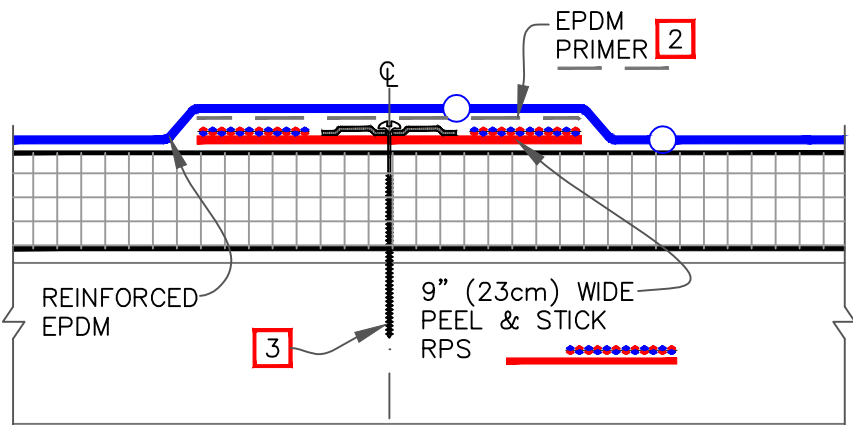
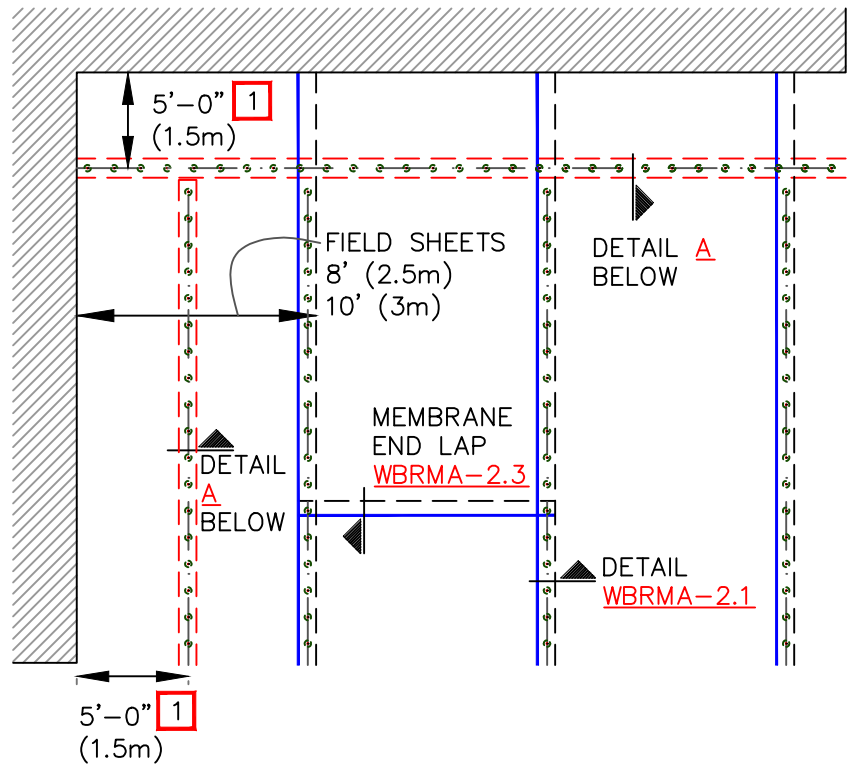

DETAIL A

NOTES:

1. REFER TO WEATHERBOND SPECIFICATIONS FOR REQUIRED NUMBER OF PERIMETER SHEETS, SHEET WIDTH AND MEMBRANE FASTENING DENSITY.
2. EPDM PRIMER MUST BE APPLIED TO THE BACK SIDE OF MEMBRANE SURFACE PRIOR TO ADHERING MEMBRANE TO PEEL & STICK RPS.
3. HPWX FASTENERS AND POLYMER SEAM PLATES ARE REQUIRED OVER STEEL DECKS.

RPS (REINFORCED TERMINATION STRIP)



MECHANICALLY ATTACHED EPDM SECUREMENT - OPTION 2 (RPS)

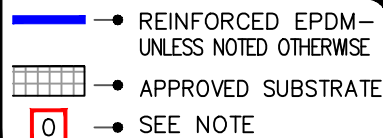

MECHANICALLY ATTACHED EPDM
WBRMA-2.0B

GUIDELINES FOR ROOF PERIMETER ZONES FOR MECHANICALLY ATTACHED ROOF SYSTEM

SPLIT LEVEL ROOFS

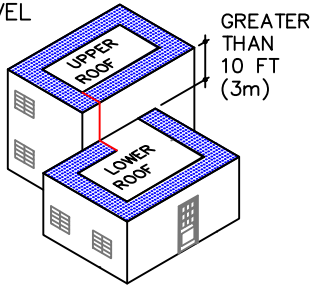

SPLIT LEVEL ROOFS

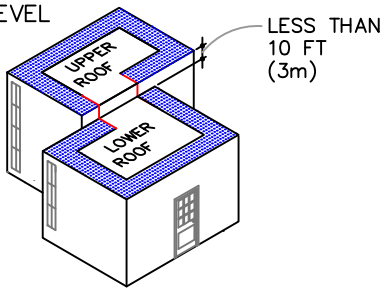

CANOPY ROOF

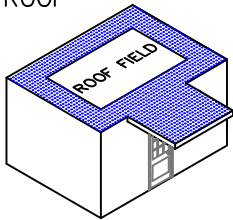

INSTALL PERIMETER SHEETS OVER THE ENTIRE OVERHANG (PROJECTION ROOF) AREA, EXTENDING ONTO THE MAIN ROOF DECK WHEN AT THE SAME LEVEL AS SHOWN.

LARGE OPENINGS OR LOADING DOCKS

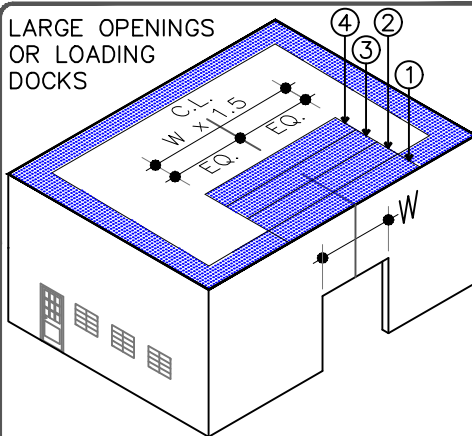

FOUR PERIMETER SHEETS CENTERED OVER LARGE OPENINGS

PERIMETER ZONES

8' (2.5m) OR 10' (3m) WIDE FIELD SHEET

9" (23cm) RPS STRIP 4

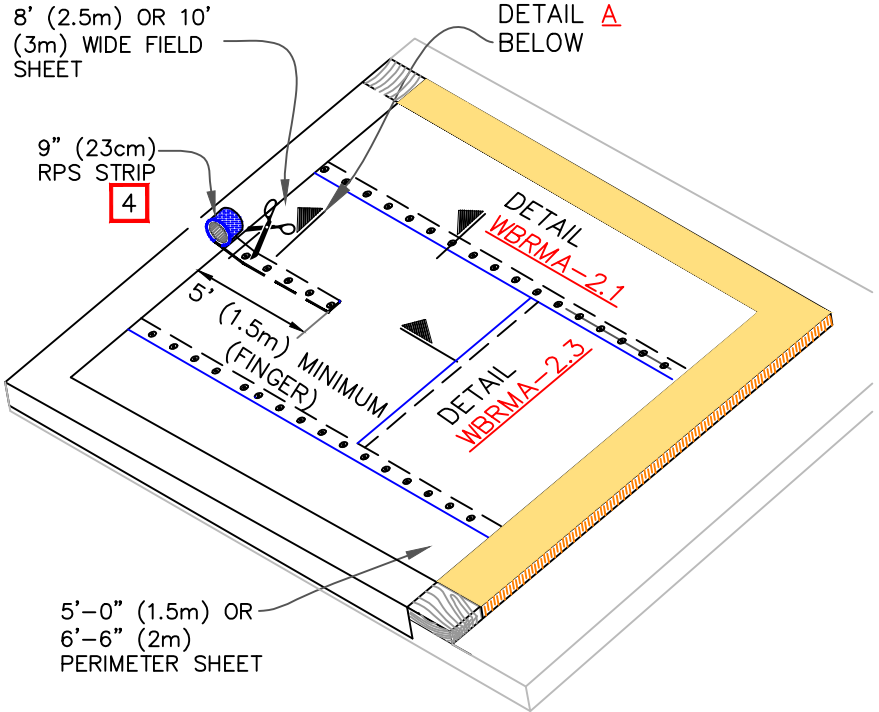

5'-0" (1.5m) OR 6'-6" (2m) PERIMETER SHEET

EPDM PRIMER 2

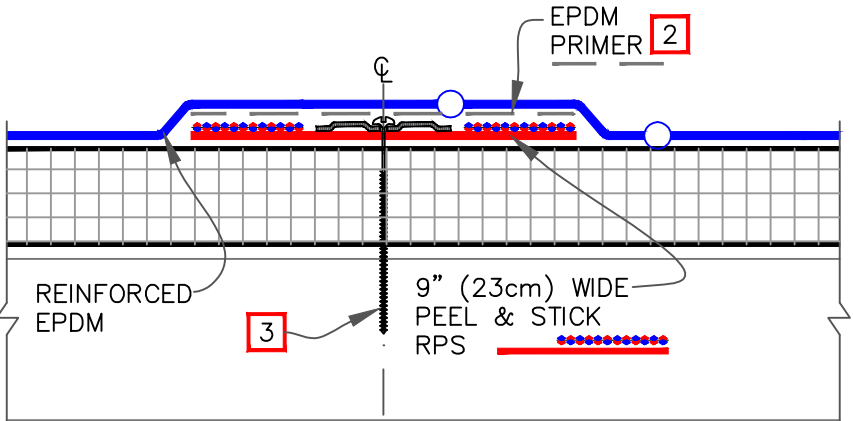

NOTES:

DETAIL A

1. REFER TO WEATHERBOND SPECIFICATIONS FOR REQUIRED NUMBER OF PERIMETER SHEETS, SHEET WIDTH AND MEMBRANE FASTENING DENSITY.
2. EPDM PRIMER MUST BE APPLIED TO THE BACK SIDE OF MEMBRANE SURFACE PRIOR TO ADHERING MEMBRANE TO PEEL & STICK RPS.
3. HPWX FASTENERS AND POLYMER SEAM PLATES ARE REQUIRED OVER STEEL DECKS.
4. RPS "FINGER" MUST EXTEND THE WIDTH OF THE REQUIRED PERIMETER.

RPS (REINFORCED PERIMETER STRIP)



MECHANICALLY ATTACHED EPDM SECUREMENT - OPTION 3 (RPS)

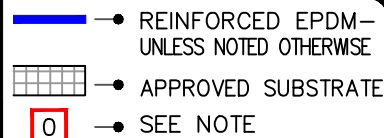

MECHANICALLY ATTACHED EPDM
WBRMA-2.0C

6" (15cm) WIDE P & S SEAM TAPE SPLICE

6" (15cm) PRE APPLIED TAPE

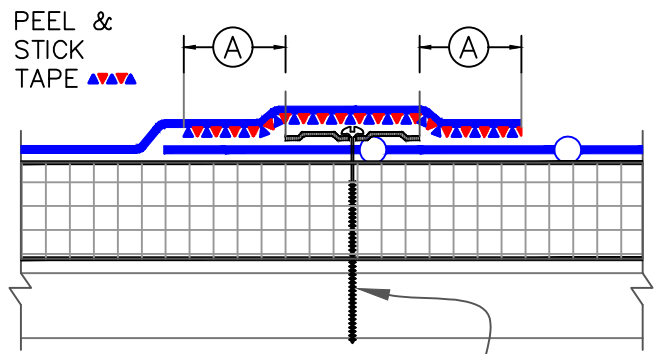
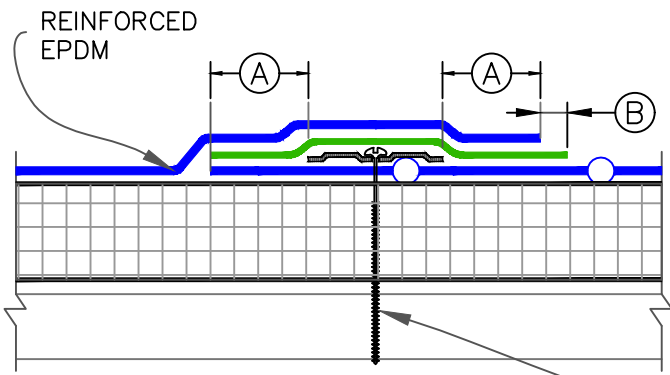

DIMENSIONS	cm	DIMENSIONS	cm	
(A)	2"	5		
(B)	1/8"	0.5	TO	
		1/2"	1.5	

SEAM PLATE & FASTENER POSITIONED OVER PRE-PRINTED BLUE MARKS. FASTEN MAX. 12" (30cm) O.C. **1**

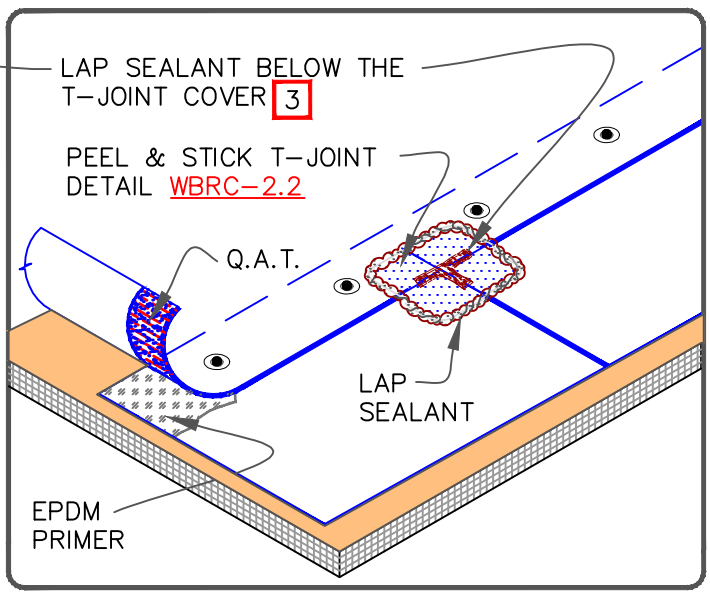
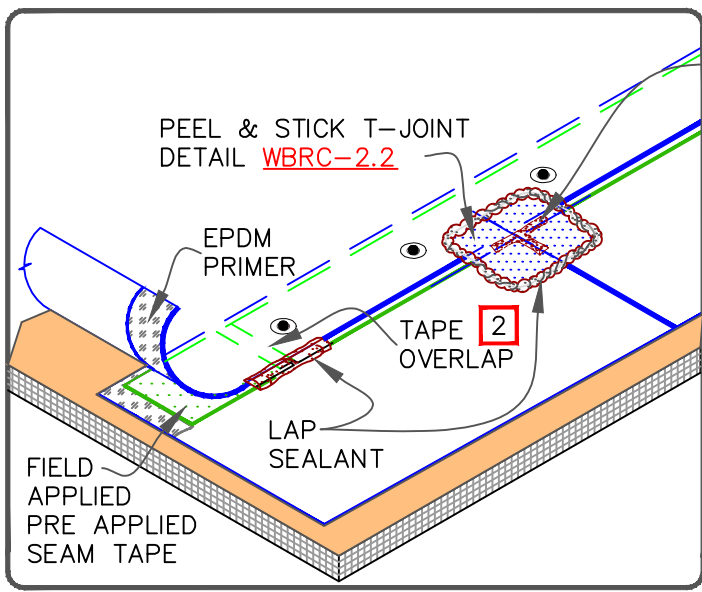

NOTES:

1. HPWX FASTENERS AND POLYMER SEAM PLATES ARE REQUIRED OVER STEEL DECKS.
2. OVERLAP THE ENDS OF FIELD APPLIED PEEL & STICK SEAM TAPE A MINIMUM OF 1" (2.5cm). APPLY LAP SEALANT AT TAPE OVERLAPS 2" (5cm) IN EACH DIRECTION AS SHOWN.
3. APPLY LAP SEALANT ALONG THE LEADING EDGE OF THE MEMBRANE SPLICE UNDER THE 6" (15cm) T-JOINT COVER, COVERING THE EXPOSED SPLICE TAPE 1/2" (1.5cm) IN ALL DIRECTIONS FROM THE SPLICE INTERSECTION.
4. END LAPS SHALL BE SPLICED USING 3" (7.5cm) WIDE P & S SEAM TAPE. REFER TO DETAIL [WBRMA-2.2](#).
5. LAP SEALANT IS REQUIRED ON CUT EDGES OF REINFORCED EPDM MEMBRANE.



MECHANICALLY ATTACHED EPDM MEMBRANE SPLICE

- REINFORCED EPDM—UNLESS NOTED OTHERWISE
- APPROVED SUBSTRATE
- SEE NOTE

MECHANICALLY ATTACHED EPDM
WBRMA-2.1

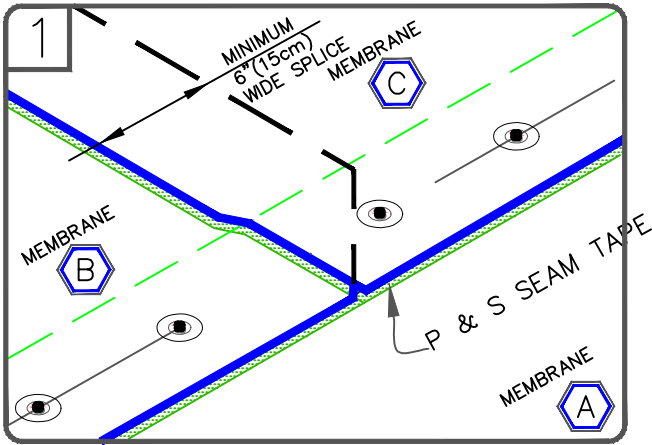

POSITION MEMBRANE TO ALLOW AN APPROXIMATE 7" (17.5cm) OVERLAP. THE PRE-MARKED LINE ON THE MEMBRANE EDGE CAN BE USED AS A GUIDE FOR TAPE PLACEMENT.

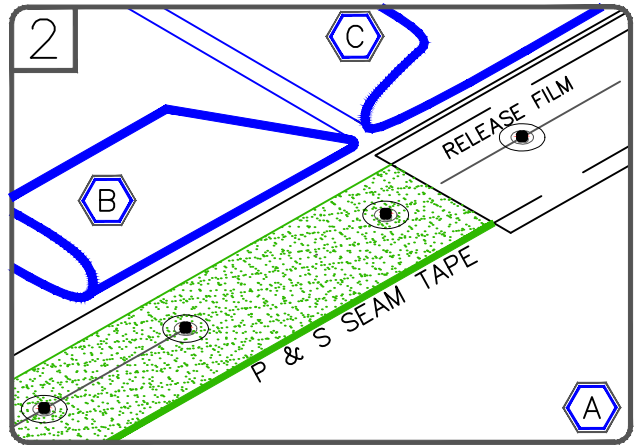

FOLD SHEETS BACK AS SHOWN. APPLY EPDM PRIMER TO THE SPLICE AREA ON BOTH SURFACES AND ALLOW TO FLASH-OFF. APPLY PEEL & STICK SEAM TAPE WITH RELEASE FILM ALIGNED WITH PRE-MARKED LINE.

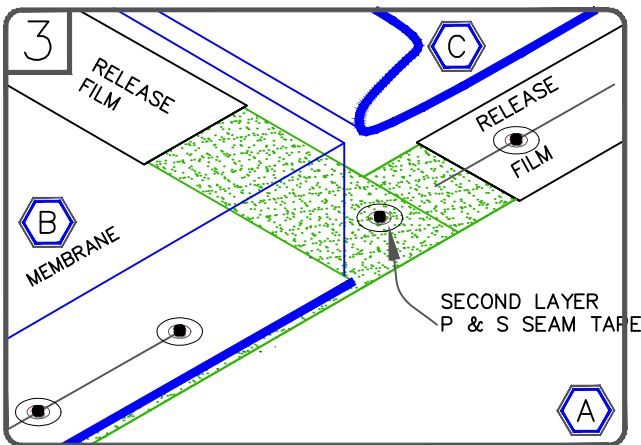

SPLICE SHEET B TO SHEET A AND APPLY SECOND PIECE OF PEEL & STICK SEAM TAPE BETWEEN SHEET B AND C. TRIM RELEASE FILM AS SHOWN.

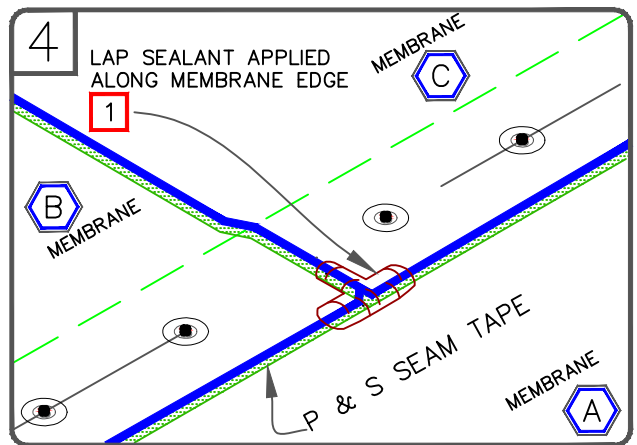

SPLICE SHEET C TO SHEET A AND B, PRESS TOP SHEET ONTO BOTTOM SHEET USING HAND PRESSURE TOWARDS THE OUTER EDGE OF THE SPLICE AND ROLL THE SPLICE AREA WITH A 2" (5cm) WIDE STEEL ROLLER.

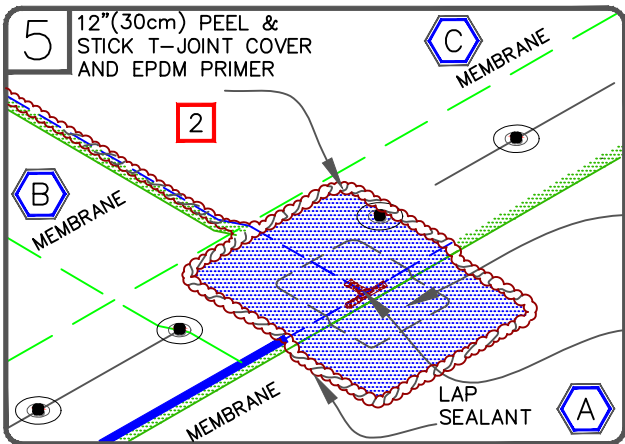

APPLY 6" (15cm) PEEL & STICK T-JOINT COVER AND 12" (30cm) PEEL & STICK T-JOINT COVER OR PEEL & STICK UNCURED CENTERED OVER THE INTERSECTING POINT OF THE LEADING EDGES OF THE FIELD SPLICE INTERSECTION AS SHOWN.

6" (15cm) PEEL & STICK T-JOINT COVER AND EPDM PRIMER
LAP SEALANT BELOW THE 6" (15cm) T-JOINT COVER

NOTES:

1. APPLY LAP SEALANT ALONG THE EDGES OF THE MEMBRANE SPLICE COVERING THE EXPOSED SPLICE TAPE 1/2" (1.5cm) IN EACH DIRECTION FROM THE SPLICE INTERSECTION.
2. APPLY LAP SEALANT AT CUT EDGES OF REINFORCED MEMBRANE AND TAPE OVER LAPS.



MECHANICALLY ATTACHED EPDM MEMBRANE SPLICE INTERSECTION (90-MIL MEMBRANES)

- REINFORCED EPDM—UNLESS NOTED OTHERWISE
- APPROVED SUBSTRATE
- SEE NOTE

MECHANICALLY ATTACHED EPDM
WBRMA-2.2

MIN. 3" (7.5cm) WIDE
PEEL & STICK SEAM
TAPE WITH EPDM
PRIMER

1/8" (0.5cm) MIN TO
1/2" (1.5cm) MAX.

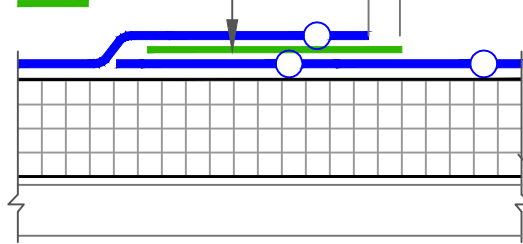

SEE 3D DETAILS BELOW

(A) UP TO 25-YEAR WARRANTY

MIN. 6" (15cm) WIDE PEEL & STICK
SEAM TAPE WITH EPDM PRIMER

1/8" (0.5cm) MIN TO
1/2" (1.5cm) MAX.

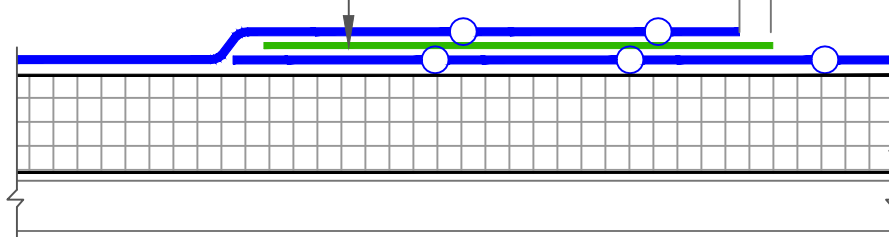

SEE 3D DETAILS BELOW

(B) UP TO 30-YEAR WARRANTY

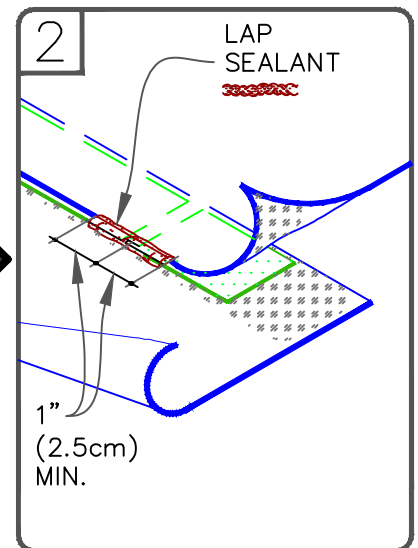
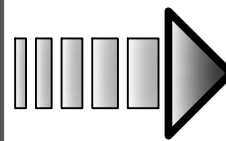
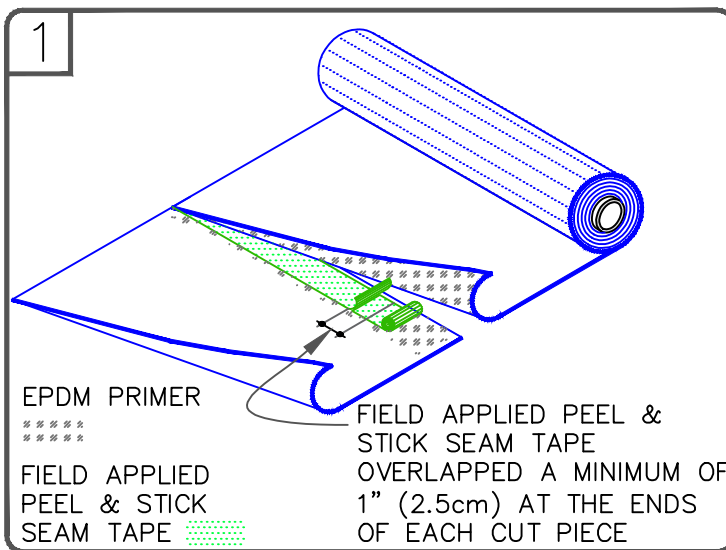

NOTES:

1. APPLY EPDM PRIMER TO THE MEMBRANE SURFACES PRIOR TO INSTALLING PEEL & STICK FLASHING.
2. LAP SEALANT IS REQUIRED ON CUT EDGES OF REINFORCED EPDM MEMBRANE.

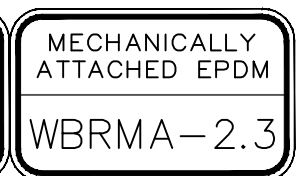
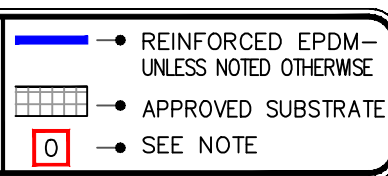

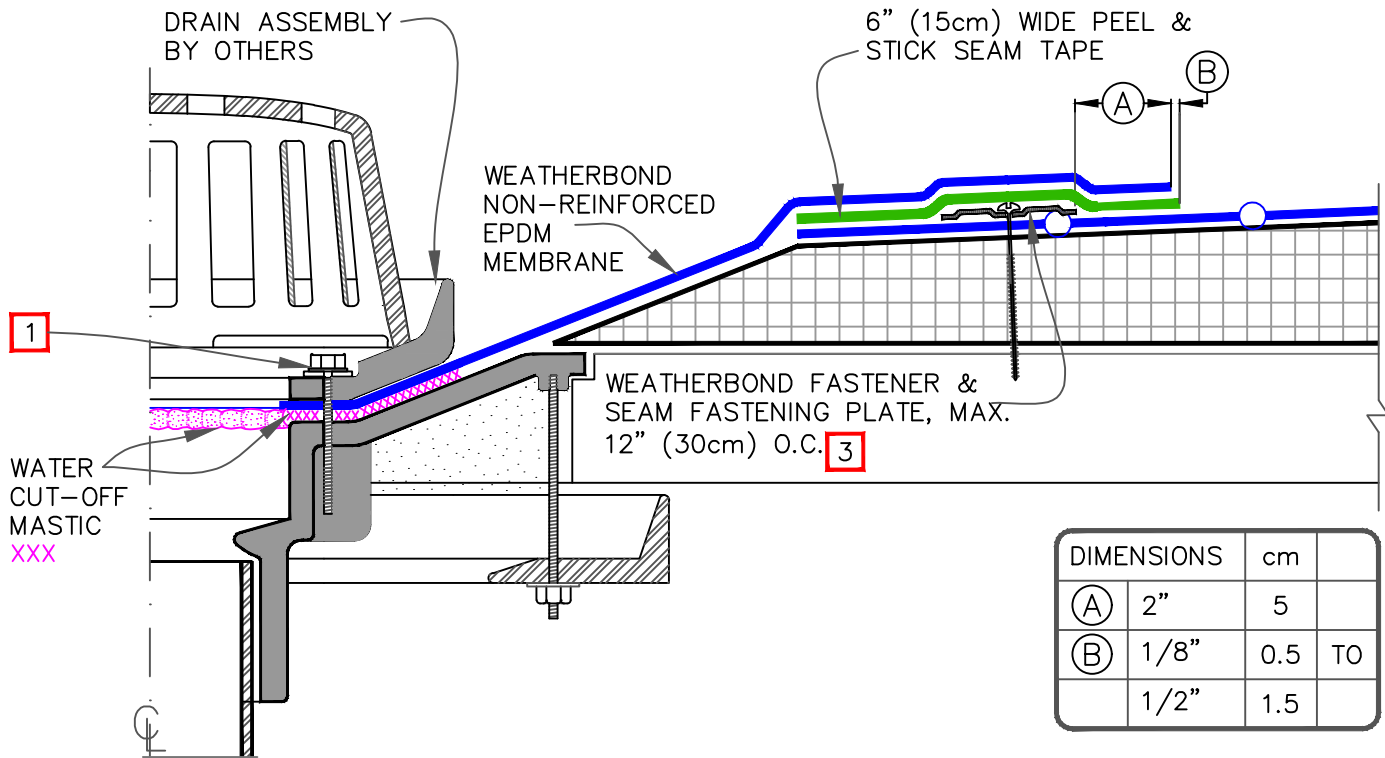

NOTES:

1. ALL BOLTS OR CLAMPS MUST BE IN PLACE TO PROVIDE CONSTANT COMPRESSION ON WATER CUT-OFF MASTIC.
2. REMOVE EXISTING LEAD, FLASHING MATERIAL & ENSURE THE DRAIN RING IS COMPLETELY CLEAN DOWN TO BARE METAL.
3. HPWX FASTENERS AND POLYMER SEAM PLATES ARE REQUIRED OVER STEEL DECKS.
4. THE HOLE IN THE MEMBRANE SHALL EXCEED THE DIAMETER OF THE DRAIN PIPE, BUT SHALL BE NO LESS THAN 1/2" (1.5cm) FROM THE ATTACHMENT POINTS OF THE DRAIN CLAMPING RING.
5. ROOF DRAIN SIZE AND NUMBER OF DRAINS SHALL BE IN ACCORDANCE WITH THE LOCAL CODES.

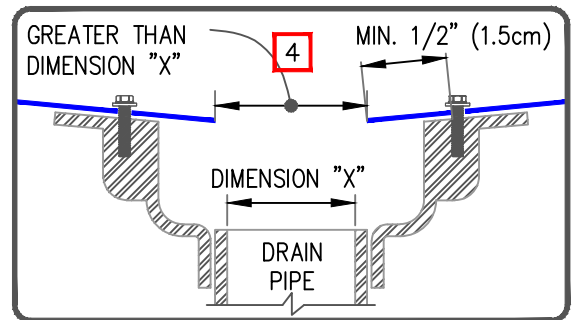

**ROOF DRAIN WITH SUMP
GREATER THAN 3" PER
FOOT**

- REINFORCED EPDM—UNLESS NOTED OTHERWISE
- APPROVED SUBSTRATE
- SEE NOTE

MECHANICALLY ATTACHED EPDM
WBRMA-6.0

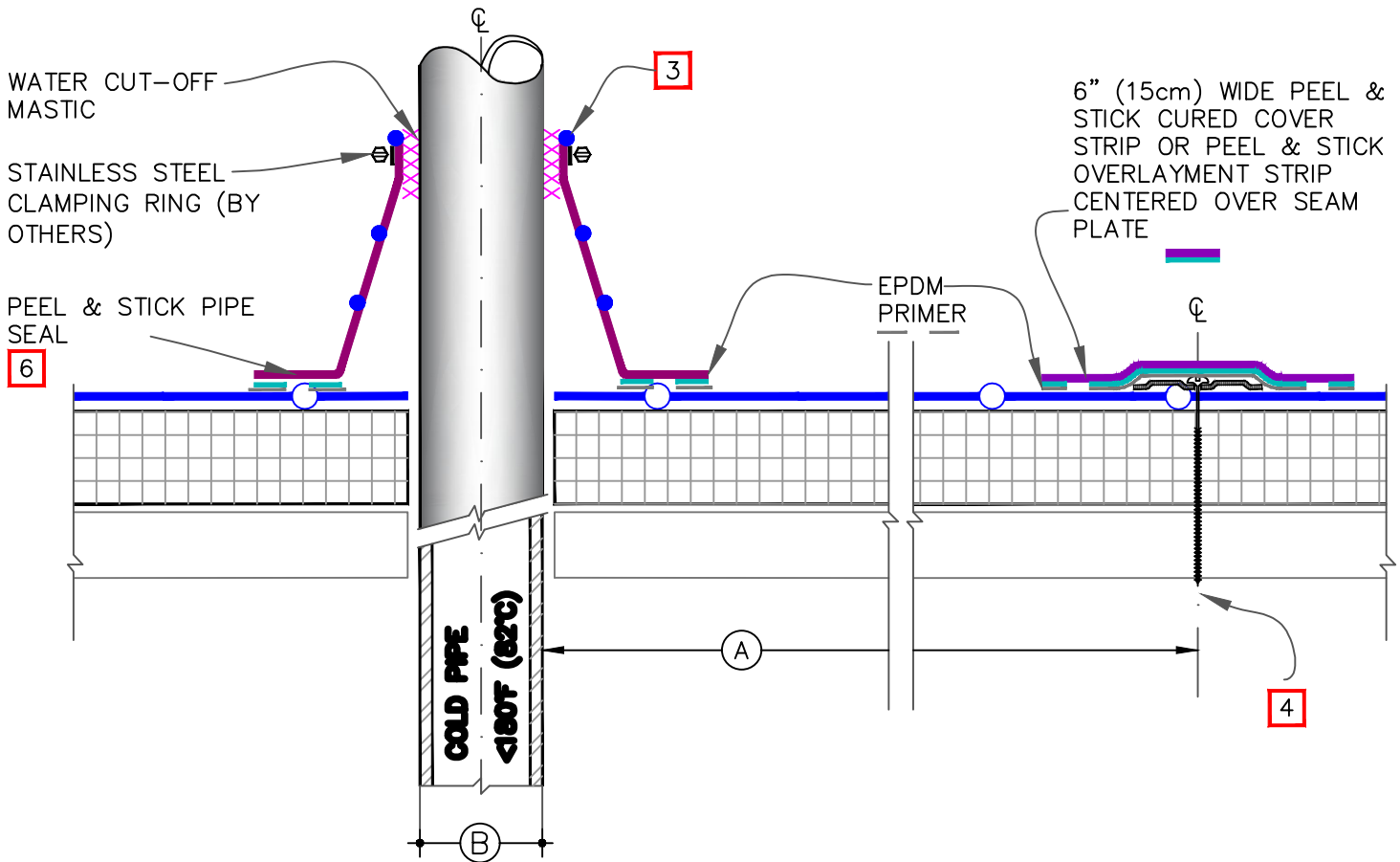

NOTES:

1. REMOVE ALL LEAD AND OTHER FLASHING BEFORE INSTALLING PIPE SEAL.
2. TEMPERATURE OF PIPE MUST NOT EXCEED 180°F (82°C).
3. PRE-MOLDED PIPE SEAL MUST HAVE RIB INTACT AT THE TOP EDGE REGARDLESS OF PIPE DIAMETER.
4. INSTALL A MINIMUM OF 4 SEAM PLATES FOR PIPES WITH A DIAMETER UP TO 6" (15cm). ADDITIONAL SEAM PLATES WILL BE REQUIRED FOR PIPES GREATER THAN 6" (15cm) IN DIAMETER AND SHALL BE SPACED 12" (30cm) ON CENTER MAXIMUM.
5. HPWX FASTENERS AND POLYMER SEAM PLATES ARE REQUIRED OVER STEEL DECKS.
6. DECK FLANGES OF THE PEEL & STICK PIPE SEAL SHALL NOT BE OVERLAPPED, CUT OR APPLIED OVER ANY ANGLE CHANGE.

DIMENSIONS		cm	
Ⓐ	6"	15	TO
	12"	30	
Ⓑ	1/2"	1.5	TO
	6"	15	



PEEL & STICK PIPE SEAL

- REINFORCED EPDM—UNLESS NOTED OTHERWISE
- APPROVED SUBSTRATE
- SEE NOTE

MECHANICALLY ATTACHED EPDM

WBRMA-8.1

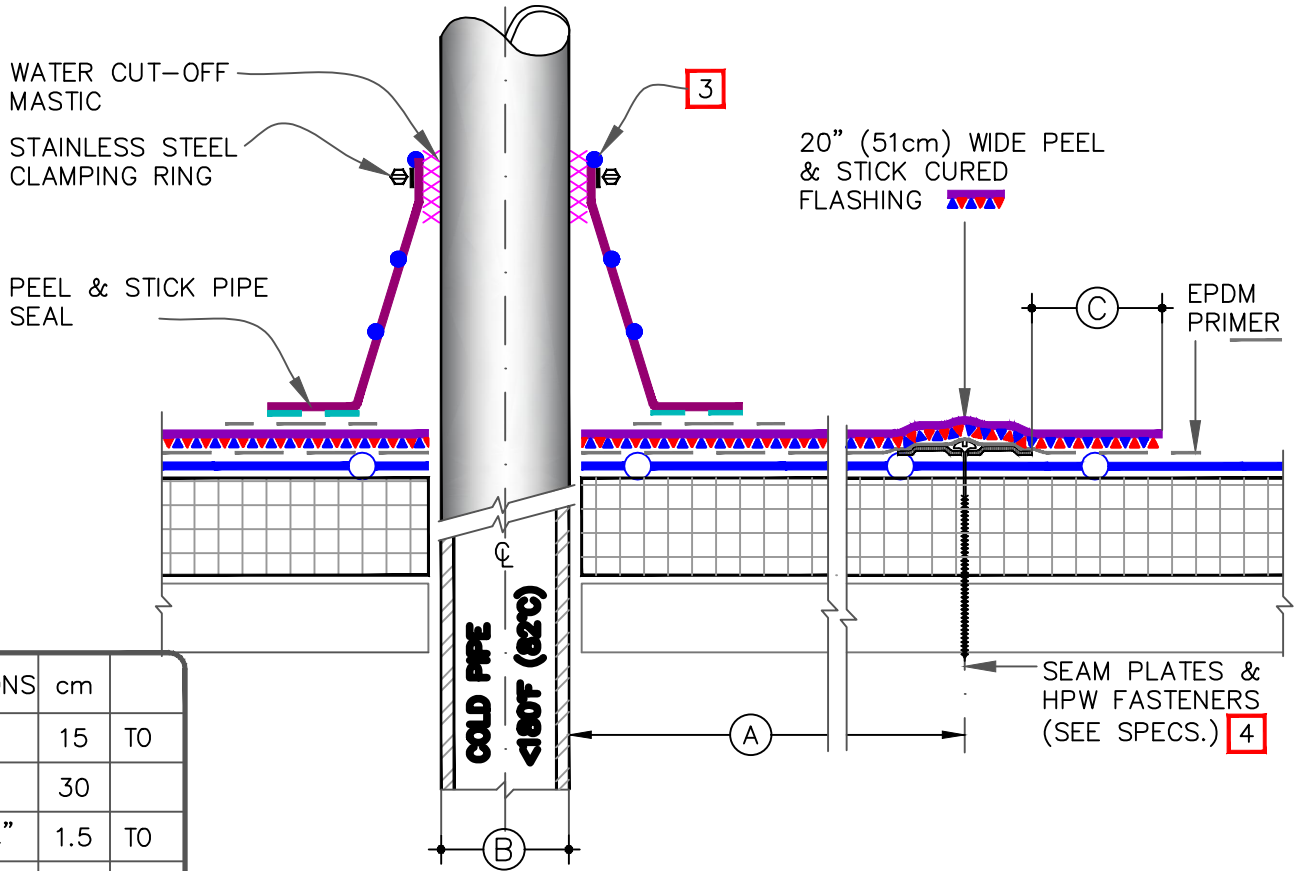

DIMENSIONS	cm	
(A)	6"	15 TO
	12"	30
(B)	1/2"	1.5 TO
	6"	15
(C)	2"	5

NOTES:

1. REMOVE ALL LEAD AND OTHER FLASHING BEFORE INSTALLING PIPE SEAL.
2. TEMPERATURE OF PIPE MUST NOT EXCEED 180°F (82°C).
3. PRE-MOLDED PIPE SEAL MUST HAVE RIB INTACT AT THE TOP EDGE REGARDLESS OF PIPE DIAMETER.
4. INSTALL A MIN. OF 4 FASTENERS FOR PIPES WITH OUTSIDE DIAMETER <6" (15cm). SEE DETAIL [WBRMA-8.2](#) WITH OPTION FOR WIDER PIPES.
5. DECK FLANGES OF THE PEEL & STICK PIPE SEAL SHALL NOT BE OVERLAPPED, CUT OR APPLIED OVER ANY ANGLE CHANGE.

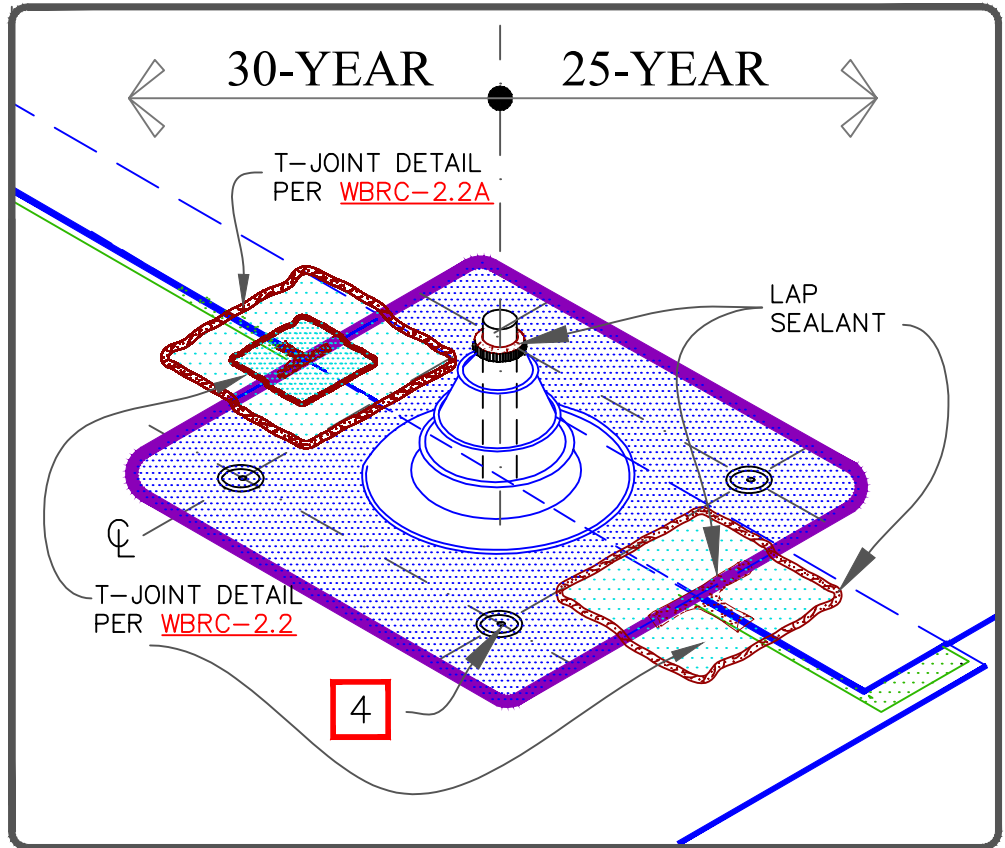

PEEL & STICK PIPE SEAL WITH 20 INCH PEEL & STICK CURED FLASHING

- REINFORCED EPDM—UNLESS NOTED OTHERWISE
- APPROVED SUBSTRATE
- SEE NOTE

MECHANICALLY ATTACHED EPDM
WBRMA-8.1A

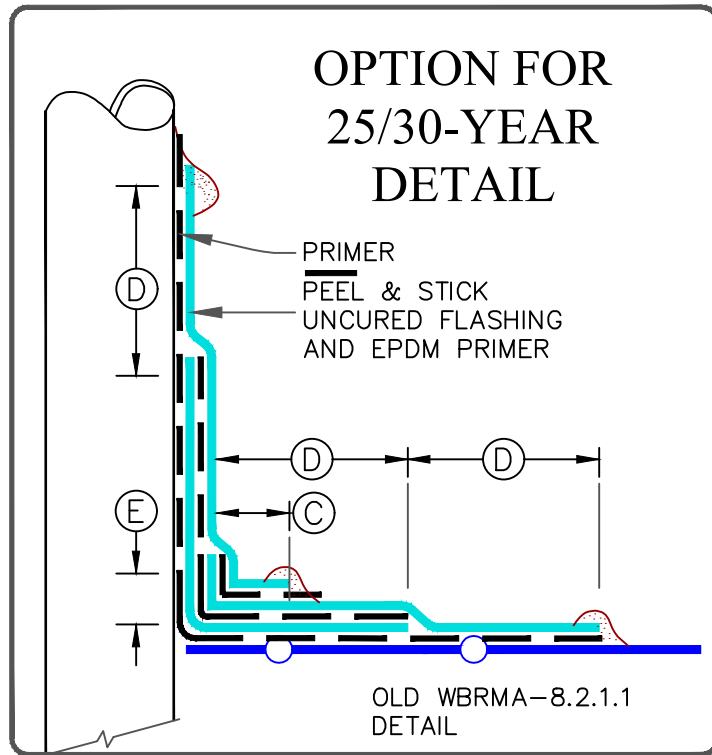
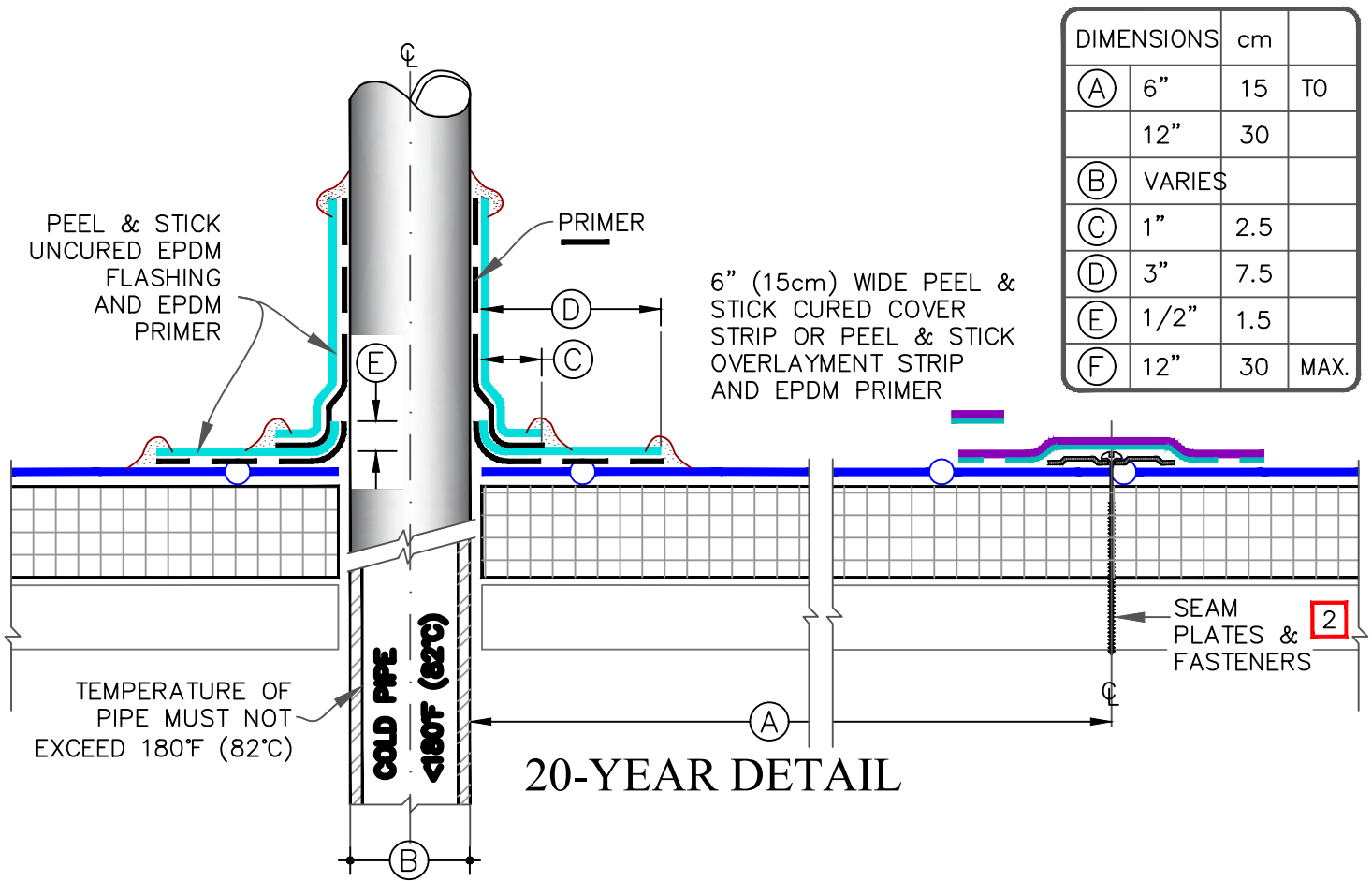

NOTES:

1. REMOVE ALL LEAD AND OTHER FLASHING BEFORE INSTALLING PAS UNCURED EPDM FLASHING.
2. HPWX FASTENERS AND POLYMER SEAM PLATES ARE REQUIRED OVER STEEL DECKS.
3. FOR STRUCTURAL STEEL TUBING GREATER THAN 12" ACROSS USE **WBRC-5** DETAILS.

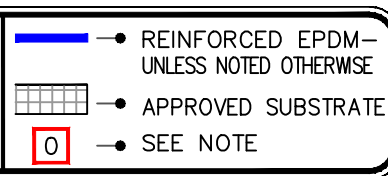
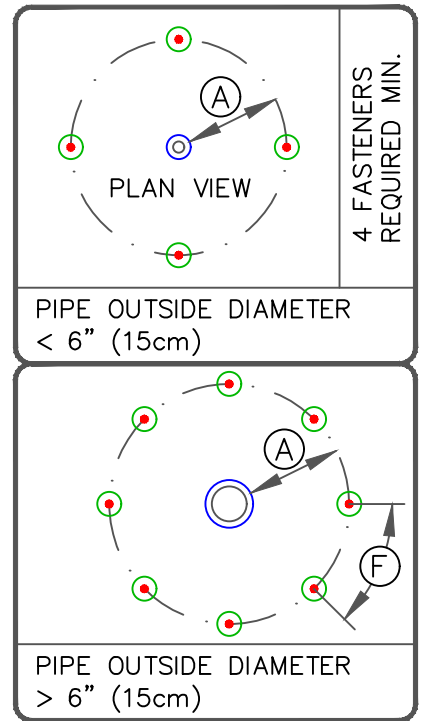

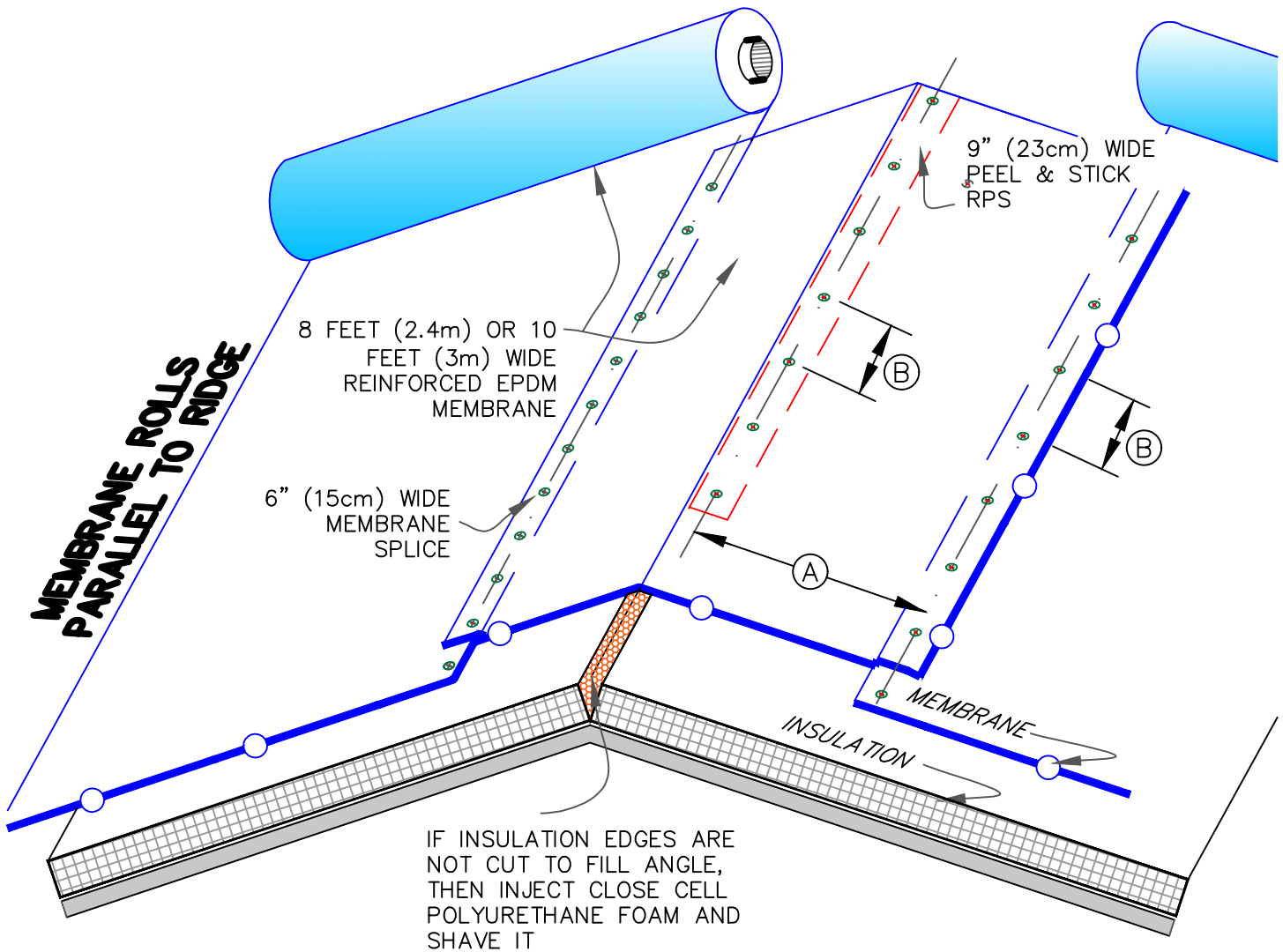

NOTES:

1. RIDGE MEMBRANE ATTACHMENT IS ONLY REQUIRED WHEN ROOF SLOPE EXCEEDS 3" TO THE HORIZONTAL FOOT (7.5cm/30cm).
2. REINFORCED EPDM MEMBRANE SHALL BE INSTALLED PARALLEL WITH RIDGE LINE (WITH MEMBRANE CENTERED OVER THE RIDGE LINE) AS SHOWN.
3. FOR PROPER MEMBRANE ATTACHMENT AND SPLICING, [REFER TO APPLICABLE WBRMA-2 DETAIL](#)
4. REFER TO WEATHERBOND SPECIFICATIONS FOR REQUIRED NUMBER OF PERIMETER SHEETS, SHEET WIDTH AND MEMBRANE FASTENING DENSITY.
5. HPWX FASTENERS AND POLYMER SEAM PLATES ARE REQUIRED OVER STEEL DECKS.
6. AS AN OPTION, 9" (23cm) WIDE PEEL & STICK RPS MAY BE USED BENEATH EPDM FIELD SHEETS FOR PERIMETER SECUREMENT.

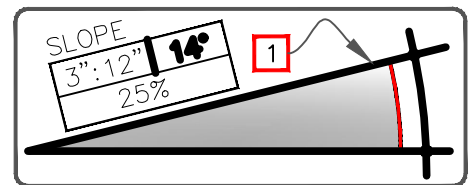

DIMENSIONS		cm	
(A)	3'-6"	110	MIN.
	4'-6"	140	MAX.
(B)	12" O.C.	30	MAX.



RIDGE MEMBRANE ATTACHMENT

- REINFORCED EPDM—UNLESS NOTED OTHERWISE
- APPROVED SUBSTRATE
- SEE NOTE

MECHANICALLY ATTACHED EPDM

WBRMA-22

NOTES:

1. DECK FLANGE MUST BE TOTALLY COVERED WITH MINIMUM 2" (5cm) COVERAGE PAST NAIL HEADS. TO REMOVE FINISHING OILS, SCRUB METAL FLANGE WITH WEATHERED MEMBRANE CLEANER; ALLOW TO DRY PRIOR TO APPLYING PRIMER.
2. LAP SEALANT MUST BE APPLIED AT FLASHING OVERLAPS AND INTERSECTIONS WITH JOINTS IN METAL EDGING.
3. T-JOINT COVER NOT NEEDED WHEN USING PEEL & STICK OVERLAYMENT STRIP ON MEMBRANE LESS THAN 90-MIL.
4. WHEN USING 90-MIL MEMBRANE INSTALL A 12" (30cm) T-JOINT COVER OVER THE 6" (15cm) T-JOINT COVER PER [WBRC-2.2A](#)
5. DETAIL NOT FOR USE WITH DESIGN "B" (BALLASTED STONE ASSEMBLY).

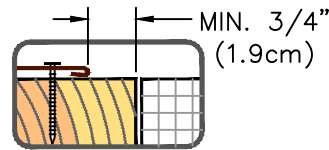
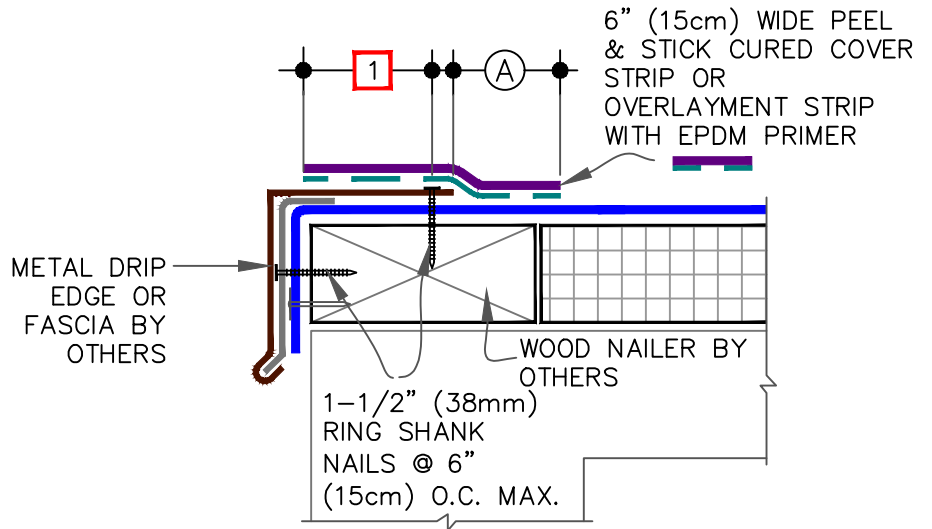

DIMENSIONS		cm	
(A)	2"	5	MIN.
(B)	1/2"	1.5	TO
	1"	2.5	

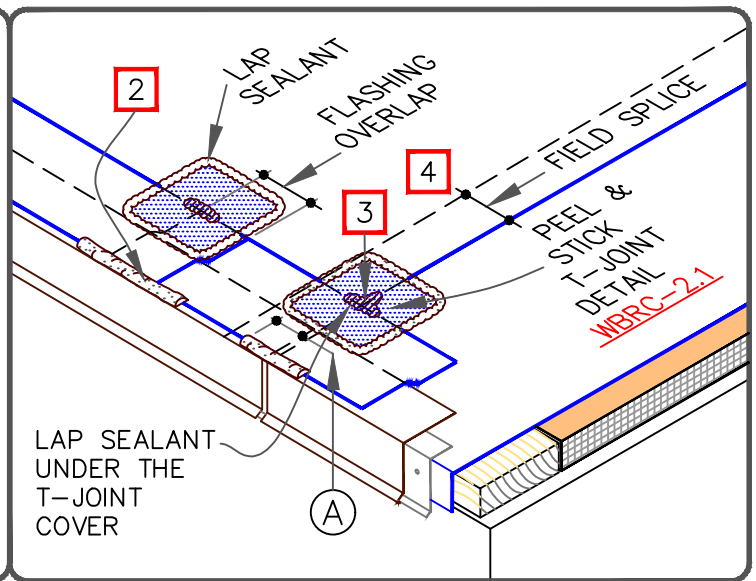
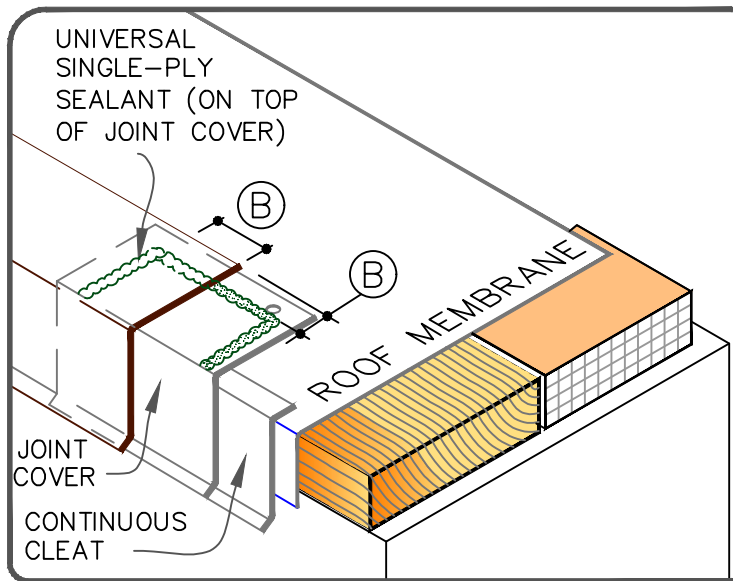

WEATHERBOND DRIP EDGE FASCIA

- • EPDM MEMBRANE
- APPROVED SUBSTRATE
- 0 • SEE NOTE

EPDM ROOFING SYSTEM

WBRC-1.1A

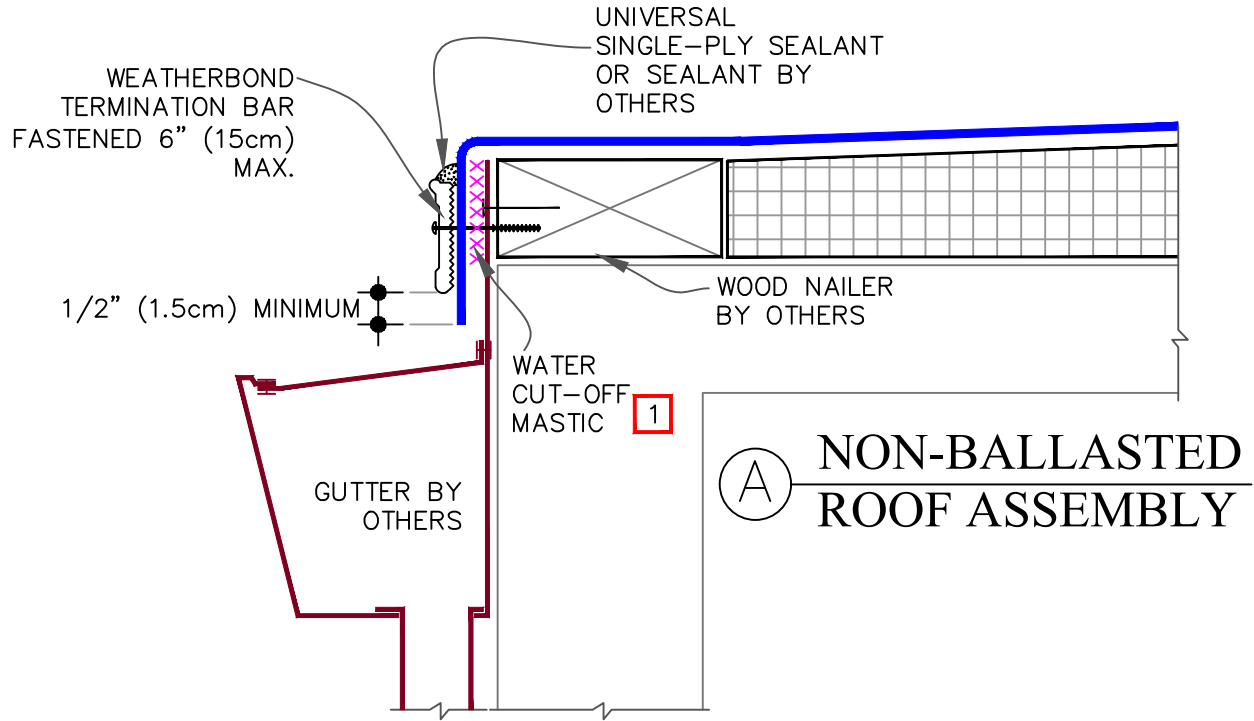

NOTES:

1. FASTENING OF METAL TERMINATION OR BALLAST RETAINING BAR MUST PROVIDE CONSTANT COMPRESSION ON WATER CUT-OFF MASTIC.
2. BALLAST RETAINING BAR MUST EXTEND ABOVE GRAVEL SURFACE SUFFICIENTLY TO RETAIN GRAVEL AND PREVENT GRAVEL MIGRATION.
3. SLOTS IN BALLAST RETAINING BAR MUST BE FLUSH OR SLIGHTLY BELOW MEMBRANE LEVEL.

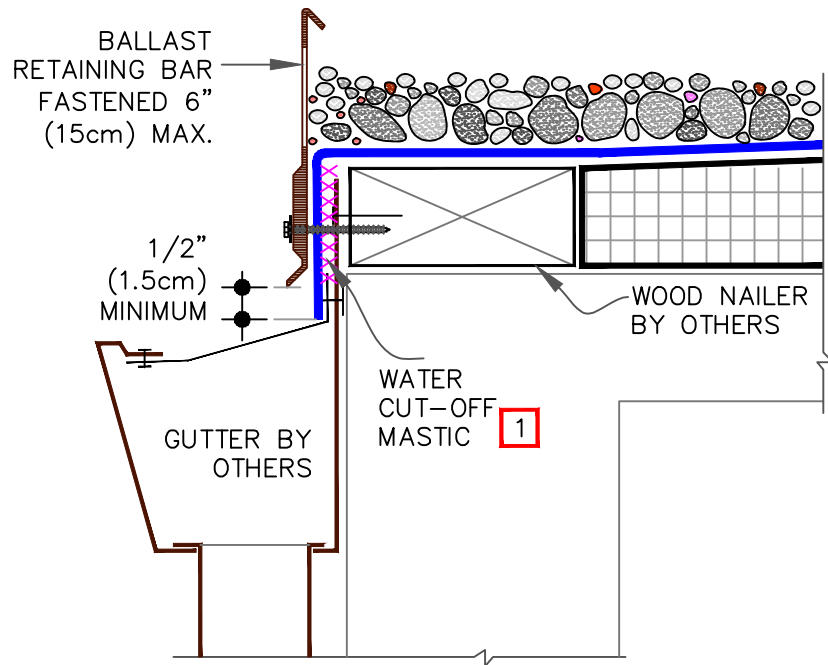

(B) BALLASTED ROOF ASSEMBLY



METAL BAR EDGE TERMINATION

- EPDM MEMBRANE
- APPROVED SUBSTRATE
- SEE NOTE

EPDM ROOFING SYSTEM
WBRC-1.3

SEAM WITH FIELD APPLIED TAPE

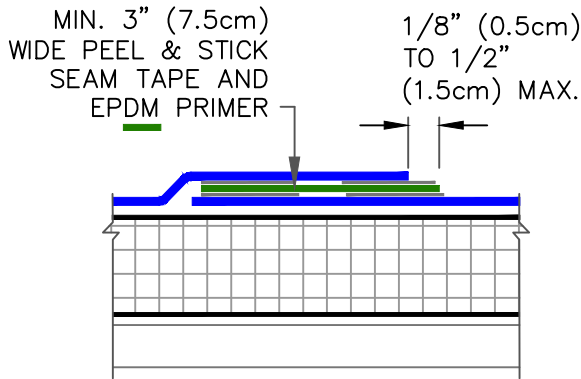

SEAM WITH FACTORY APPLIED SEAM TAPE

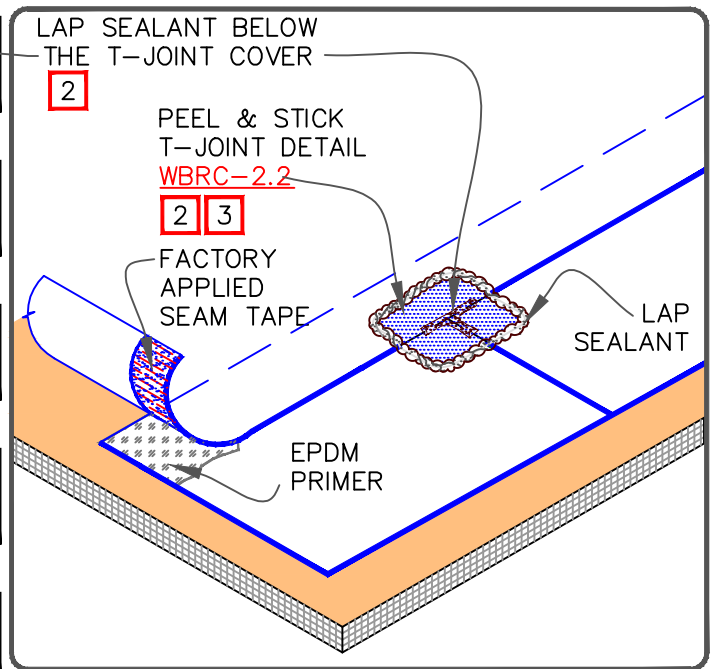
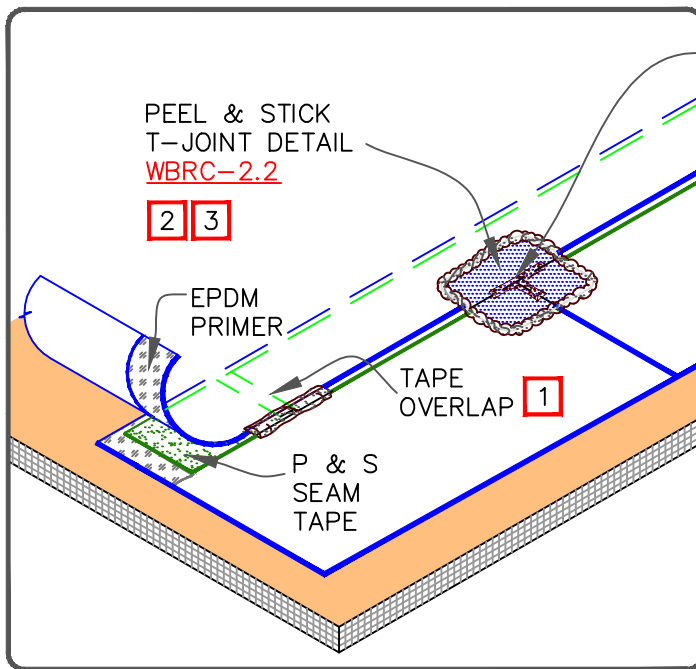
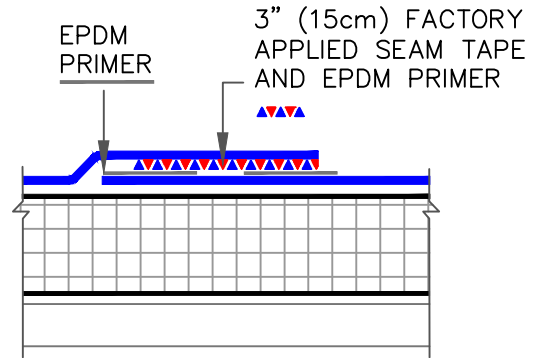

NOTES:

1. OVERLAP THE ENDS OF THE FIELD APPLIED P & S SEAM TAPE A MINIMUM OF 1" (2.5cm). APPLY LAP SEALANT AT TAPE OVERLAPS 2" (5cm) IN EACH DIRECTION AS SHOWN.
2. APPLY LAP SEALANT ALONG THE EXPOSED EDGE OF THE MEMBRANE SPLICE COVERING THE EXPOSED SPLICE TAPE 1/2" (1.5cm) IN EACH DIRECTION FROM THE SPLICE INTERSECTION AND OVERLAY WITH A 6" (15cm) T-JOINT COVER.
3. WHEN USING 90-MIL MEMBRANE, INSTALL A 12" (30cm) T-JOINT COVER CENTERED OVER THE FIRST T-JOINT COVER PER DETAIL [WBRC-2.2A](#).
4. LAP SEALANT IS REQUIRED ON CUT EDGES OF REINFORCED EPDM MEMBRANE.
5. REFER TO DETAIL [WBRMA-2.1](#) FOR MECHANICALLY FASTENED SPLICES.



EPDM MEMBRANE SPLICES

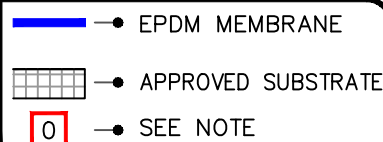

EPDM ROOFING SYSTEM

WBRC-2.1A

OPTION 1: NARROW SEAM WITH OVERLAYMENT

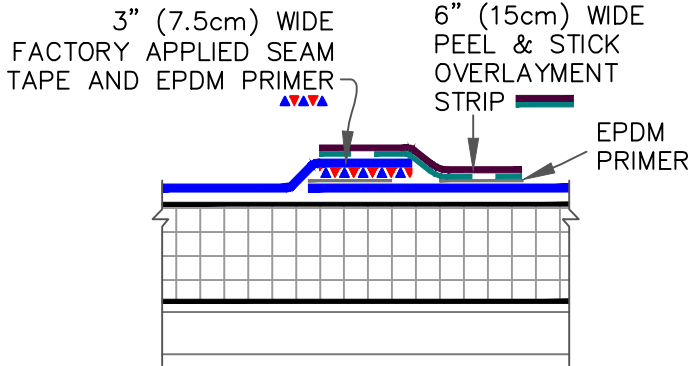

OPTION 2: WIDER SEAM

6" (15cm) WIDE
FACTORY APPLIED SEAM
TAPE AND EPDM PRIMER

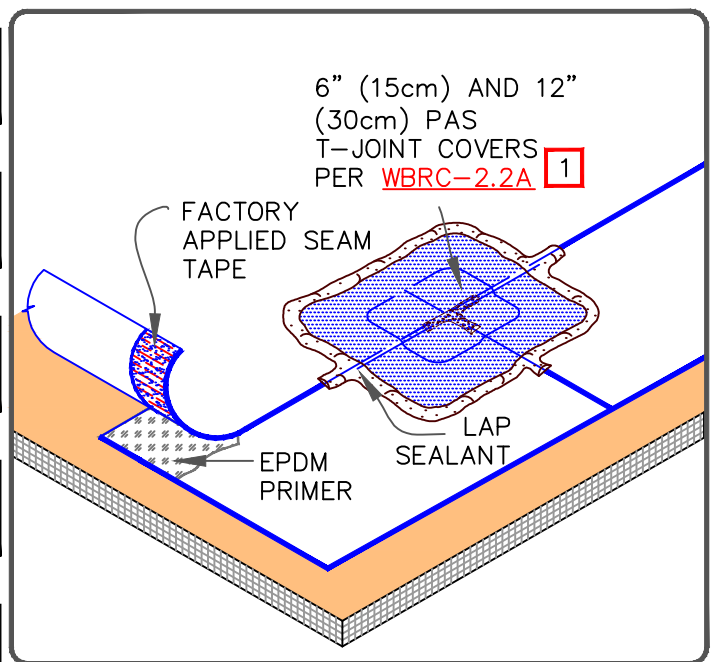
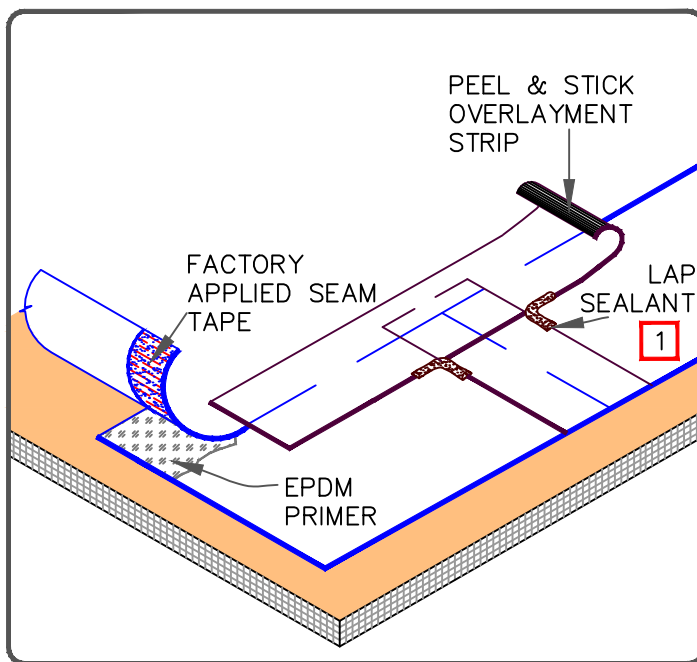
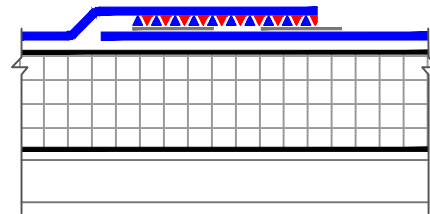

PAS (PEEL & STICK)

NOTES:

1. APPLY LAP SEALANT AT ALL INTERSECTIONS BETWEEN PEEL & STICK OVERLAYMENT STRIP.
2. REFER TO DETAIL [WBRMA-2.1A](#) FOR MECHANICALLY-FASTENED SPLICES.

NOTE:

1. APPLY LAP SEALANT ALONG THE EXPOSED EDGE OF THE MEMBRANE SPLICE COVERING THE EXPOSED SPLICE TAPE 1/2" (1.5cm) IN EACH DIRECTION FROM THE SPLICE INTERSECTION AND OVERLAY WITH A 6" (15cm) T-JOINT COVER. INSTALL A 12" (30cm) T-JOINT COVER CENTERED OVER THE FIRST T-JOINT COVER PER DETAIL [WBRC-2.2A](#).



EPDM MEMBRANE
SPLICES- PROJECTS WITH
90-MIL MEMBRANE

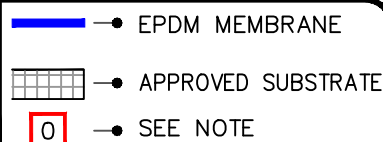

EPDM ROOFING
SYSTEM

WBRC-2.1B

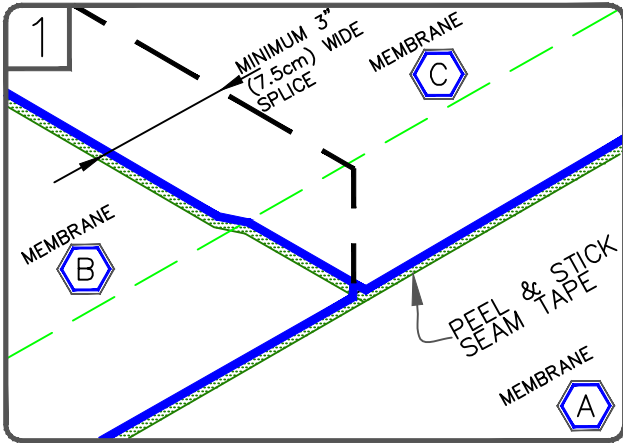

POSITION MEMBRANE TO ALLOW AN APPROXIMATE 4" (10cm) OVERLAP. MARK THE BOTTOM SHEET WITH AN INDELIBLE MARKER 1/2" (1.5cm) FROM THE EDGE OF THE TOP SHEET AS SHOWN. THE PRE-MARKED LINE ON THE MEMBRANE EDGE CAN ALSO BE USED AS A GUIDE.

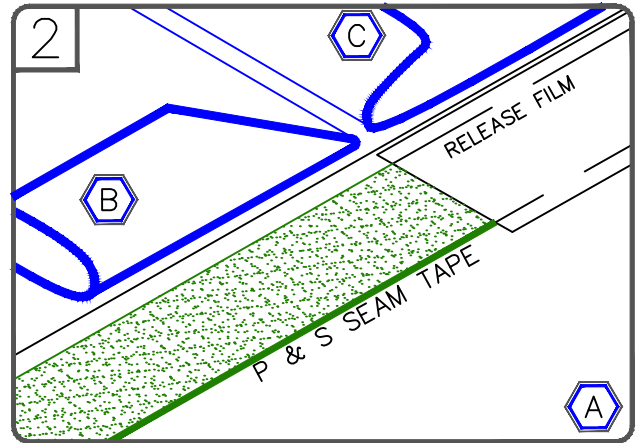

FOLD SHEETS BACK AS SHOWN. APPLY EPDM PRIMER TO THE SPLICE AREA ON BOTH SURFACES AND ALLOW TO FLASH-OFF. APPLY P & S SEAM TAPE WITH RELEASE FILM ALIGNED WITH MARKED LINE.

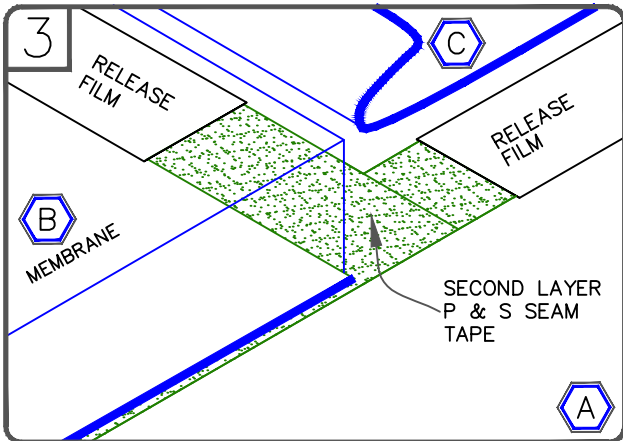

SPLICE SHEET B TO SHEET A AND APPLY SECOND PIECE OF P & S SEAM TAPE BETWEEN SHEET B AND C. TRIM RELEASE FILM AS SHOWN.

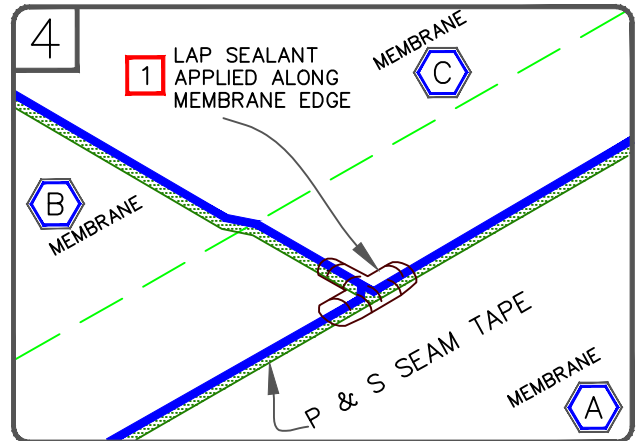

SPLICE SHEET C TO SHEET A AND B, PRESS TOP SHEET ONTO BOTTOM SHEET USING HAND PRESSURE TOWARDS THE OUTER EDGE OF THE SPLICE AND ROLL THE SPLICE AREA WITH A 2" (5cm) WIDE STEEL ROLLER.

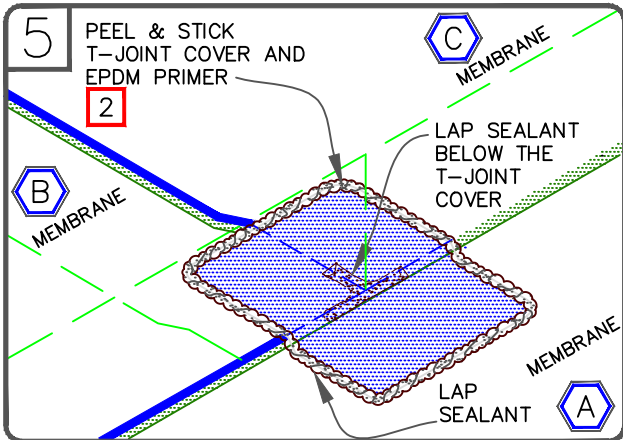

APPLY PEEL & STICK T-JOINT COVER OR 6" (15cm) WIDE SECTION OF PEEL & STICK UNCURED FLASHING CENTERED OVER THE INTERSECTING POINT OF THE LEADING EDGES OF THE FIELD SPLICE INTERSECTION AS SHOWN.

NOTES:

1. APPLY LAP SEALANT ALONG THE EDGE OF THE MEMBRANE SPLICE BELOW THE 6" (15cm) T-JOINT COVER, COVERING THE EXPOSED SPLICE TAPE 1/2" (1.5cm) IN EACH DIRECTION FROM THE SPLICE INTERSECTION.
2. APPLY LAP SEALANT AT CUT EDGES OF REINFORCED MEMBRANE AND TAPE OVERLAPS. REFER TO [DETAIL WBRC-2.1](#).
3. REFER TO [DETAIL WBRC-2.2A](#) WHEN USING 90-MIL MEMBRANE.

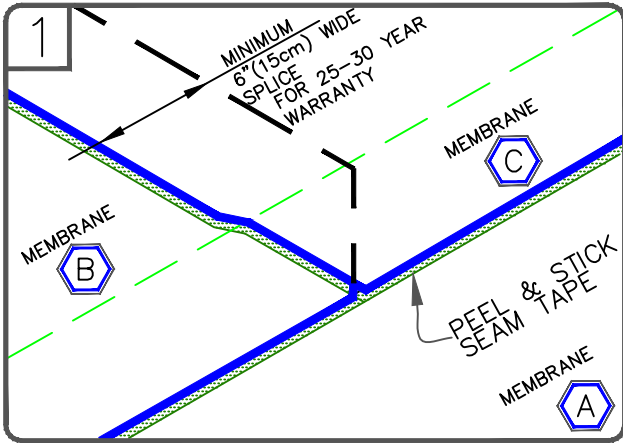

POSITION MEMBRANE TO ALLOW AN APPROXIMATE 7" (17.5cm) OVERLAP. MARK THE BOTTOM SHEET WITH AN INDELIBLE MARKER 1/2" (1.5cm) FROM THE EDGE OF THE TOP SHEET AS SHOWN. THE PRE-MARKED LINE ON THE MEMBRANE EDGE CAN ALSO BE USED AS A GUIDE.

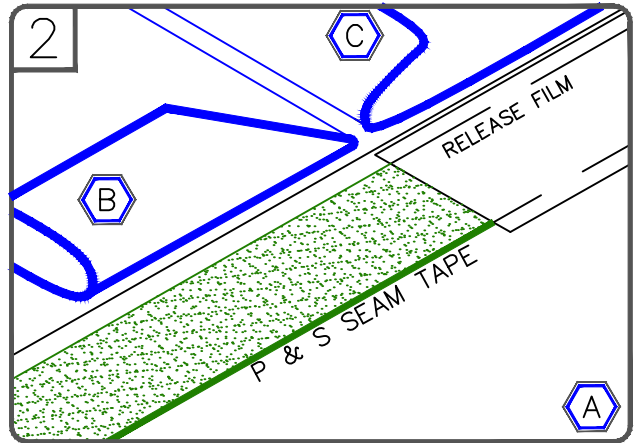

FOLD SHEETS BACK AS SHOWN. APPLY EPDM PRIMER TO THE SPLICE AREA ON BOTH SURFACES AND ALLOW TO FLASH-OFF. APPLY P & S SEAM TAPE WITH RELEASE FILM ALIGNED WITH MARKED LINE.

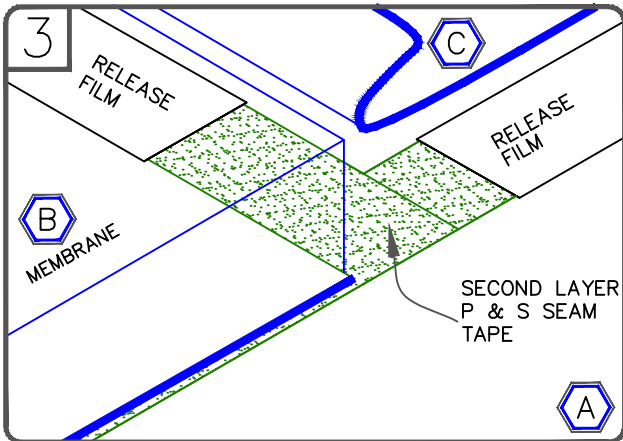

SPLICE SHEET B TO SHEET A AND APPLY SECOND PIECE OF P & S SEAM TAPE BETWEEN SHEET B AND C. TRIM RELEASE FILM AS SHOWN.

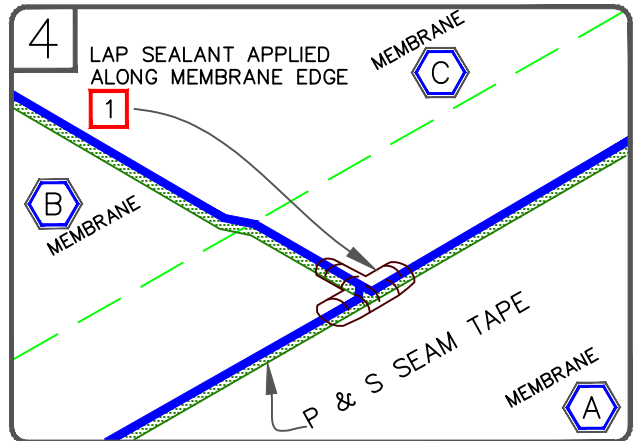

SPLICE SHEET C TO SHEET A AND B, PRESS TOP SHEET ONTO BOTTOM SHEET USING HAND PRESSURE TOWARDS THE OUTER EDGE OF THE SPLICE AND ROLL THE SPLICE AREA WITH A 2" (5cm) WIDE STEEL ROLLER.

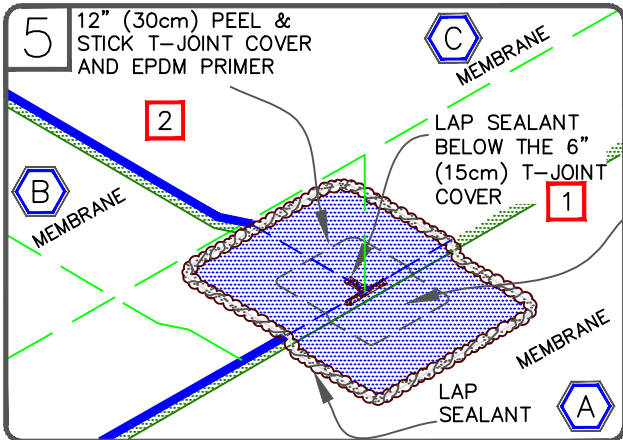



APPLY 6" (15cm) PEEL & STICK T-JOINT COVER AND 12" (30cm) PEEL & STICK T-JOINT COVER OR PEEL & STICK UNCURED CENTERED OVER THE INTERSECTING POINT OF THE LEADING EDGES OF THE FIELD SPLICE INTERSECTION AS SHOWN.

NOTES:

1. APPLY LAP SEALANT ALONG THE EDGES OF THE MEMBRANE SPLICE COVERING THE EXPOSED SPLICE TAPE 1/2" (15cm) IN EACH DIRECTION FROM THE SPLICE INTERSECTION.
2. APPLY LAP SEALANT AT CUT EDGES OF REINFORCED MEMBRANE AND TAPE OVER LAPS.



EPDM MEMBRANE SPLICE INTERSECTION (90mil MEMBRANE)

-  EPDM MEMBRANE
-  APPROVED SUBSTRATE
-  SEE NOTE

EPDM ROOFING SYSTEM
WBRC-2.2A

CONTINUOUS WALL FLASHING

SEPARATE WALL FLASHING

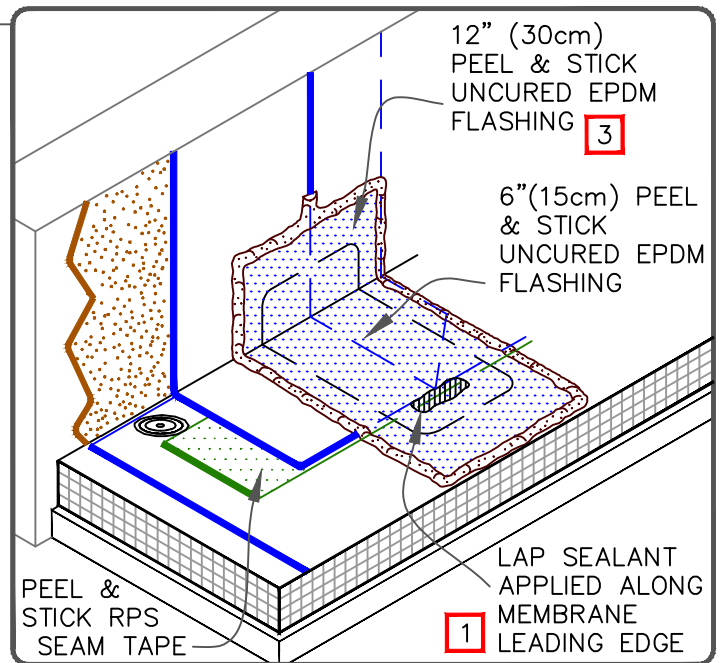
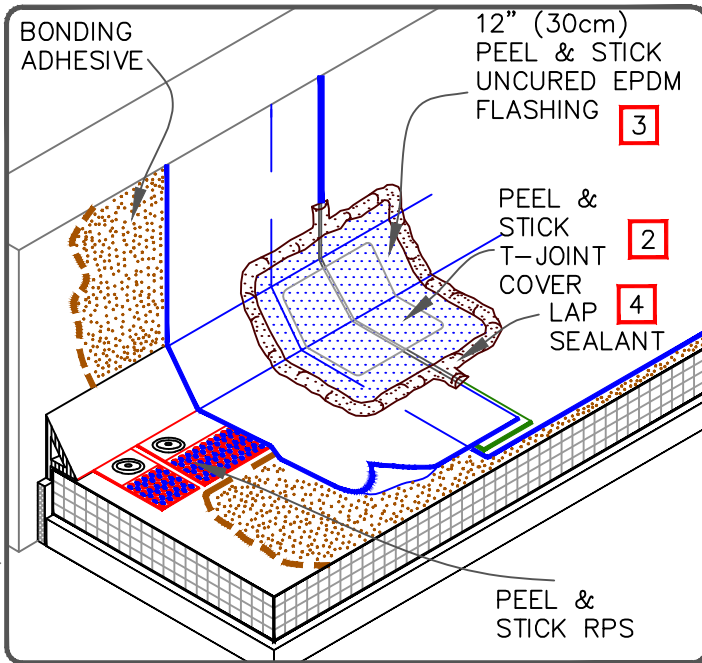

CONTINUOUS WALL FLASHING

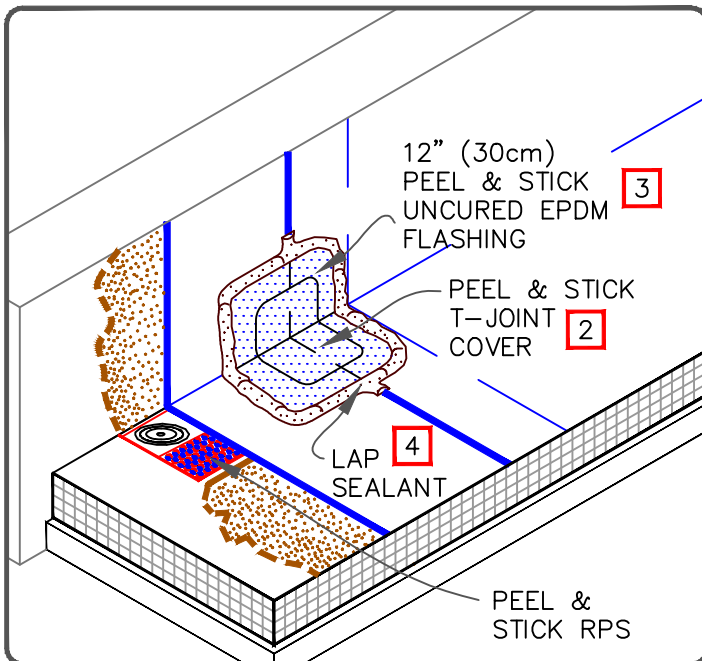

NOTES:

1. APPLY LAP SEALANT ALONG THE LEADING EDGE OF THE MEMBRANE SPLICE (UNDER THE PEEL & STICK UNCURED FLASHING) COVERING THE EXPOSED SPLICE TAPE APPROXIMATELY 1/2" (1.5cm) BEYOND THE SPLICE EDGE.
2. PEEL & STICK T-JOINT COVER OR 6" (15cm) WIDE PEEL & STICK FLASHING, WITH EPDM PRIMER, MUST BE CENTERED OVER FIELD SPLICES AT THE ANGLE CHANGE.
3. PROJECTS WITH 30-YEAR WARRANTY OR WHEN USING 90-MIL MEMBRANE REQUIRE FIELD SPLICES TO BE OVERLAID WITH TWO LAYERS OF PEEL & STICK UNCURED EPDM FLASHING. THE BOTTOM LAYER SHALL BE 6" (15cm) WIDE COVERED WITH A 12" (30cm) WIDE TOP LAYER. BOTH LAYERS SHALL BE CENTERED.
4. SEAL EXPOSED LAYER WITH LAP SEALANT.

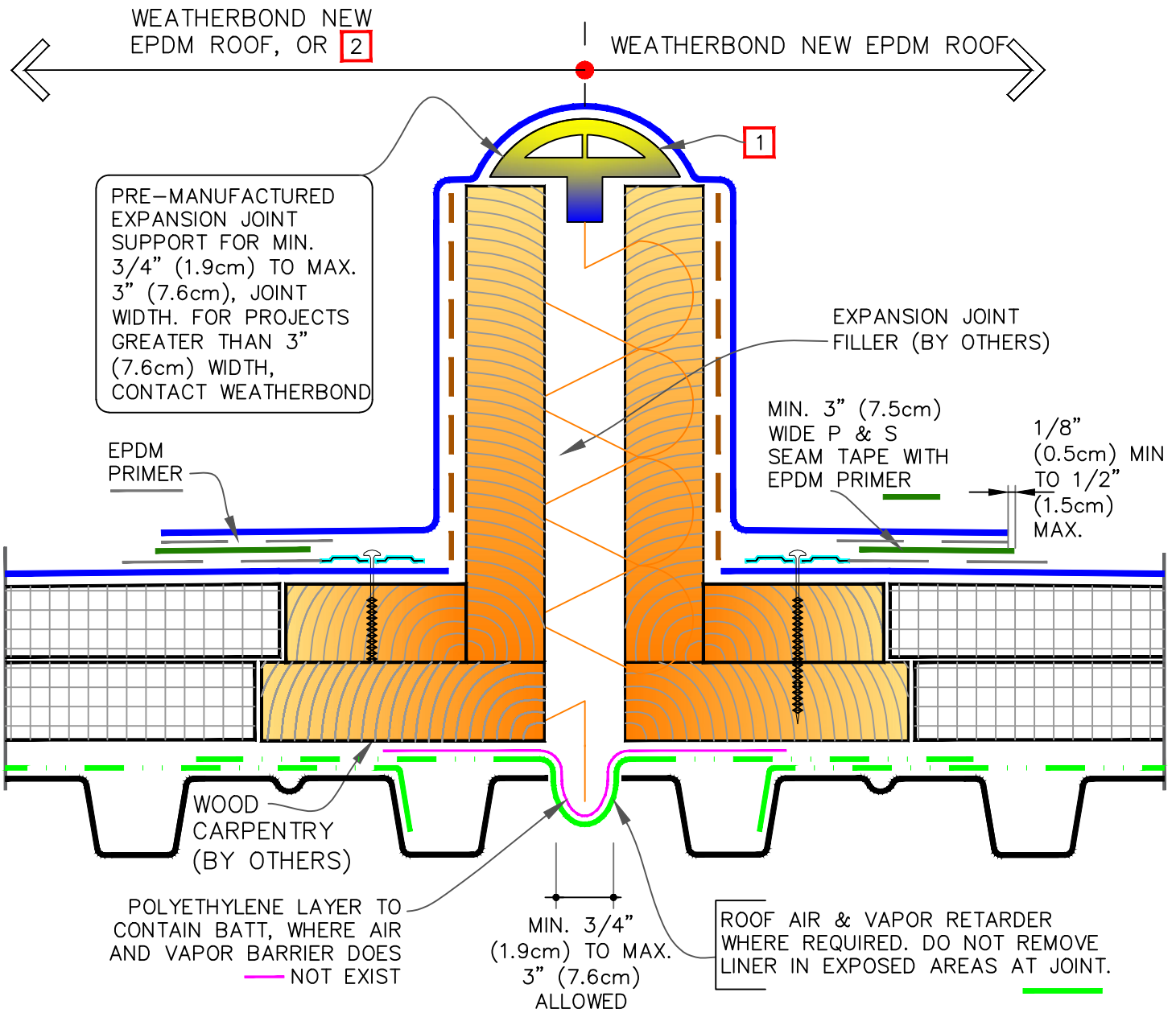

NOTES:

1. MEMBRANE FLASHING SHALL NOT BE ADHERED OVER THE EXPANSION JOINT SUPPORT.
2. IN CASE THE ROOF TYPE IS DIFFERENT, DESIGNER TO PROVIDE ROOF TYPE AND ITS CONDITION TO WEATHERBOND TO DEVELOP A TIE-IN DETAIL ON THIS SIDE ACCORDINGLY.



DECK-TO-DECK CURBED EXPANSION DETAIL

- EPDM MEMBRANE
- APPROVED SUBSTRATE
- SEE NOTE

EPDM ROOFING SYSTEM
WBRC-3A.1

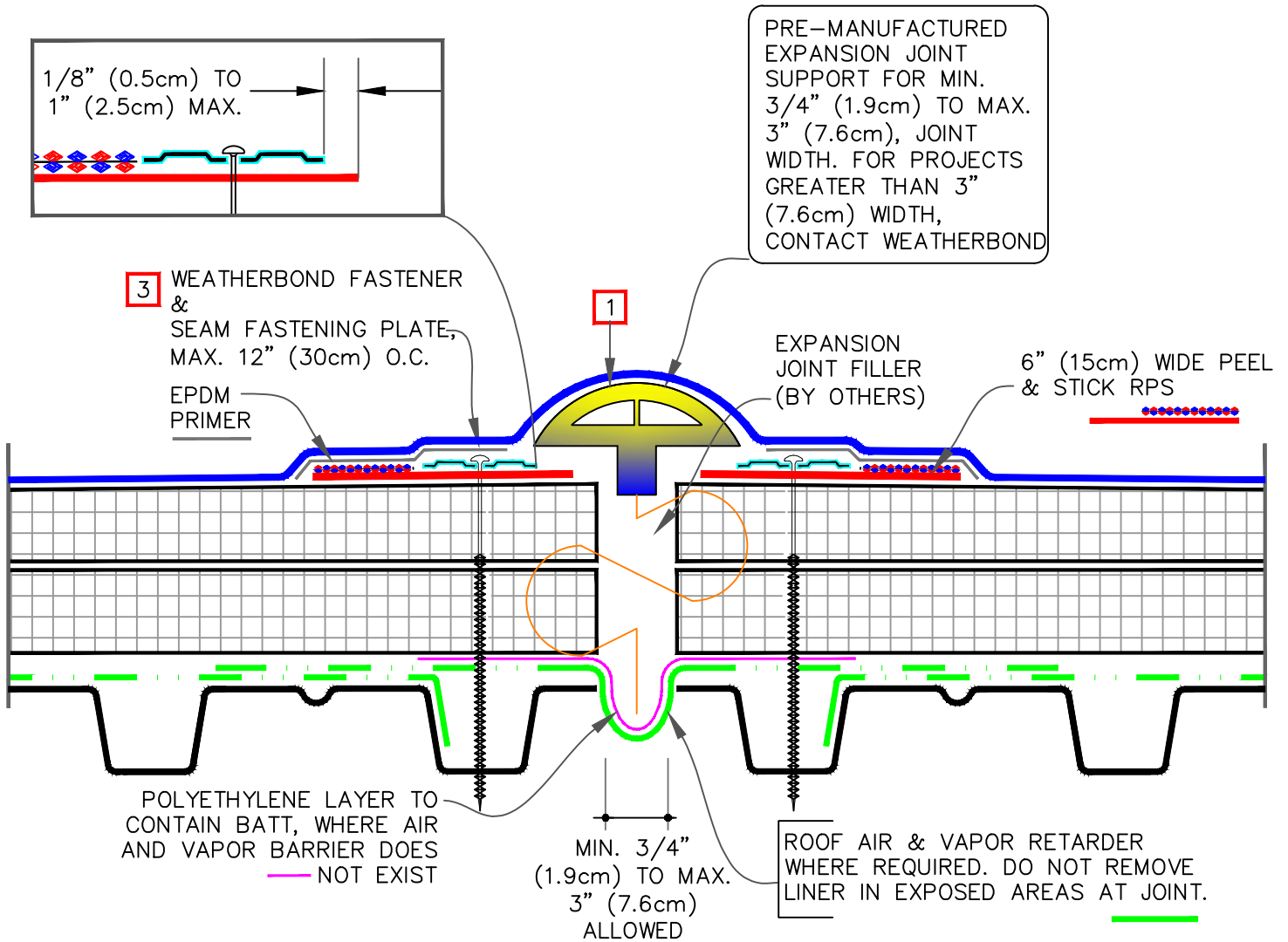

NOTES:

1. MEMBRANE SHALL NOT BE ADHERED OVER THE EXPANSION JOINT SUPPORT.
2. FOR EXPANSION JOINT INTERSECTIONS AND INTERSECTIONS BETWEEN EXPANSION JOINTS TO WALL OR EDGING, USE TWO LAYERS OF PEEL & STICK UNCURED EPDM FLASHING WITH SECOND LAYER 3" (7.5cm) LARGER THAN PREVIOUS LAYER IN ALL DIRECTIONS.
3. HPWX FASTENERS AND POLYMER SEAM PLATES ARE REQUIRED ON MECHANICALLY FASTENED SYSTEMS OVER STEEL DECKS.



DECK-TO-DECK
EXPANSION JOINT

—● EPDM MEMBRANE

—● APPROVED SUBSTRATE

0 —● SEE NOTE

EPDM ROOFING SYSTEM

WBRC-3.1

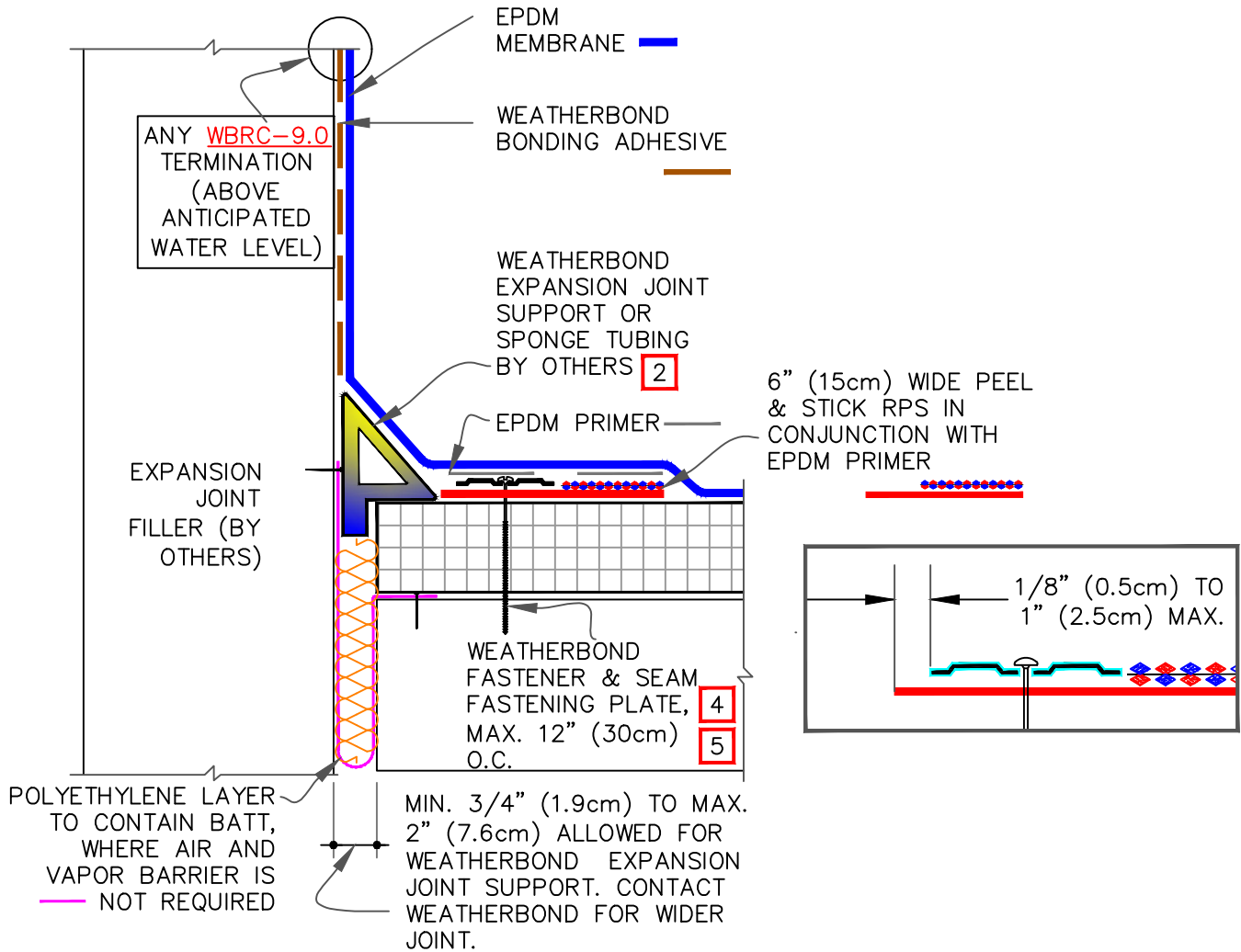

NOTES:

1. ALL OUTSIDE AND INSIDE CORNERS REQUIRE TWO COMPLETE CORNER APPLICATIONS OF PEEL & STICK UNCURED FLASHING AS PER [DETAILS WBRC-15.4A OR WBRC-15.8](#).
2. ROOF MEMBRANE SHALL BE LOOSE-LAID OVER THE EXPANSION JOINT SUPPORT OR SPONGE TUBING.
3. USE [DETAIL WBRC-2.3](#) FOR EPDM MEMBRANE SPLICES AT ANGLE CHANGES.
4. HPWX FASTENERS AND POLYMER SEAM PLATES ARE REQUIRED ON MECHANICALLY FASTENED SYSTEMS OVER STEEL DECKS.



DECK-TO-WALL
EXPANSION JOINT

- EPDM MEMBRANE
- APPROVED SUBSTRATE
- 0 SEE NOTE

EPDM ROOFING
SYSTEM
WBRC-3.2

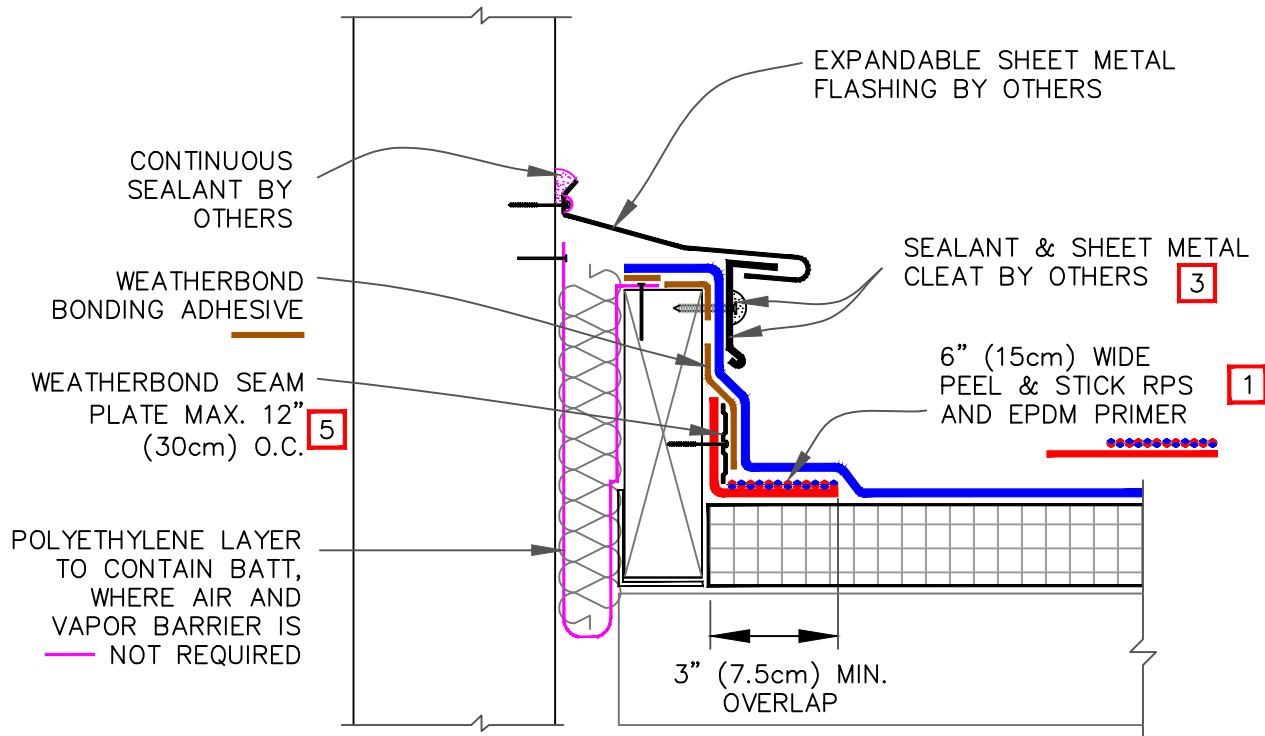

NOTES:

1. QUICK APPLIED RPS MAY BE INSTALLED INTO THE STRUCTURAL DECK. HPWX FASTENERS AND POLYMER SEAM PLATES ARE REQUIRED ON MECHANICALLY-FASTENED ROOFING SYSTEMS OVER STEEL DECKS.
2. USE [DETAIL WBRC-2.3](#) FOR EPDM MEMBRANE SPLICES AT ANGLE CHANGES.
3. SEAL FASTENERS BY APPLYING WATER CUT-OFF MASTIC UNDER THE COUNTER-FLASHING, OR USING EPDM WASHERS, OR CAULKING THE FASTENERS HEAD.

ALL OUTSIDE AND INSIDE CORNERS REQUIRE TWO COMPLETE CORNER APPLICATIONS OF PEEL & STICK UNCURED EPDM FLASHING AS PER [DETAILS WBRC-15.4A OR WBRC-15.8](#).



SHEAR/EXPANSION JOINT

- EPDM MEMBRANE
- APPROVED SUBSTRATE
- 0 SEE NOTE

EPDM ROOFING SYSTEM

WBRC-3.3

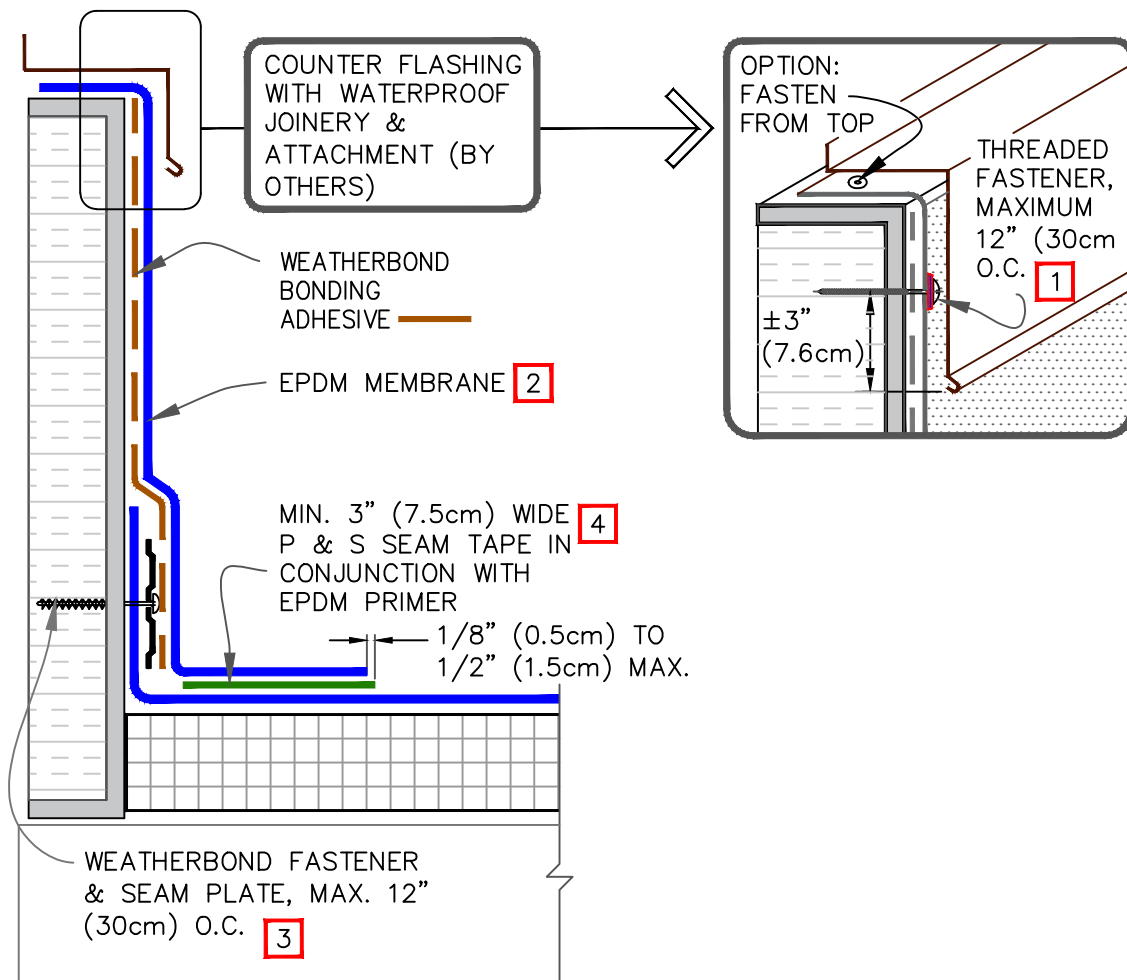

NOTES:

1. IN CASE THE THREADED FASTENERS ARE USED TO PENETRATE THE METAL COUNTER-FLASHING, USE EPDM WASHERS, APPLY WATER CUT-OFF MASTIC UNDER THE COUNTER-FLASHING OR SEAL THE FASTENER HEADS WITH SEALANT.
2. LAP SEALANT IS REQUIRED ON CUT-EDGES OF REINFORCED MEMBRANE.
3. SEAM PLATES AND FASTENERS MAY BE INSTALLED INTO THE STRUCTURAL DECK AND THEN HPWX FASTENERS AND POLYMER SEAM PLATES ARE REQUIRED FOR MECHANICALLY-FASTENED ROOFING SYSTEMS OVER STEEL DECKS.
4. MEMBRANE SPLICES SHALL INCORPORATE 3" (7.6cm) WIDE P & S SEAM TAPE.
5. IF THE VERTICAL SPLICE ON THE CURB FLASHING IS NOT LOCATED AT THE CORNER, USE DETAIL [WBRC-2.3](#) FOR EPDM MEMBRANE SPLICES AT ANGLE CHANGES.

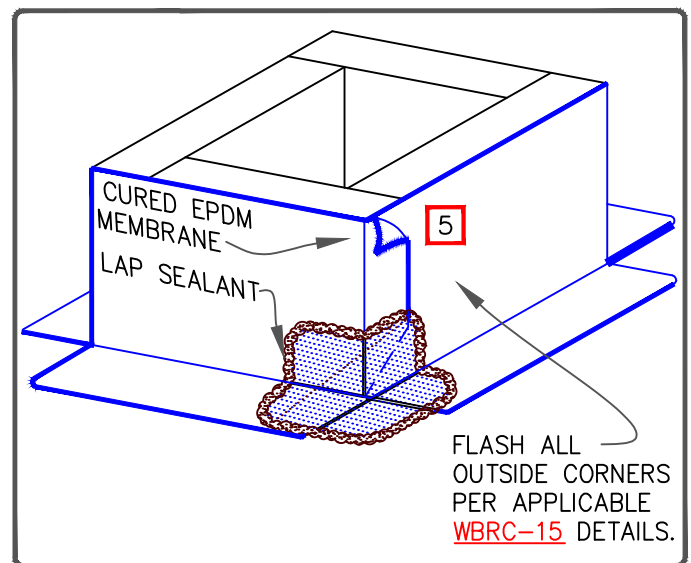

CURB FLASHINGS

- EPDM MEMBRANE
- APPROVED SUBSTRATE
- SEE NOTE

EPDM ROOFING SYSTEM

WBRC-5.1

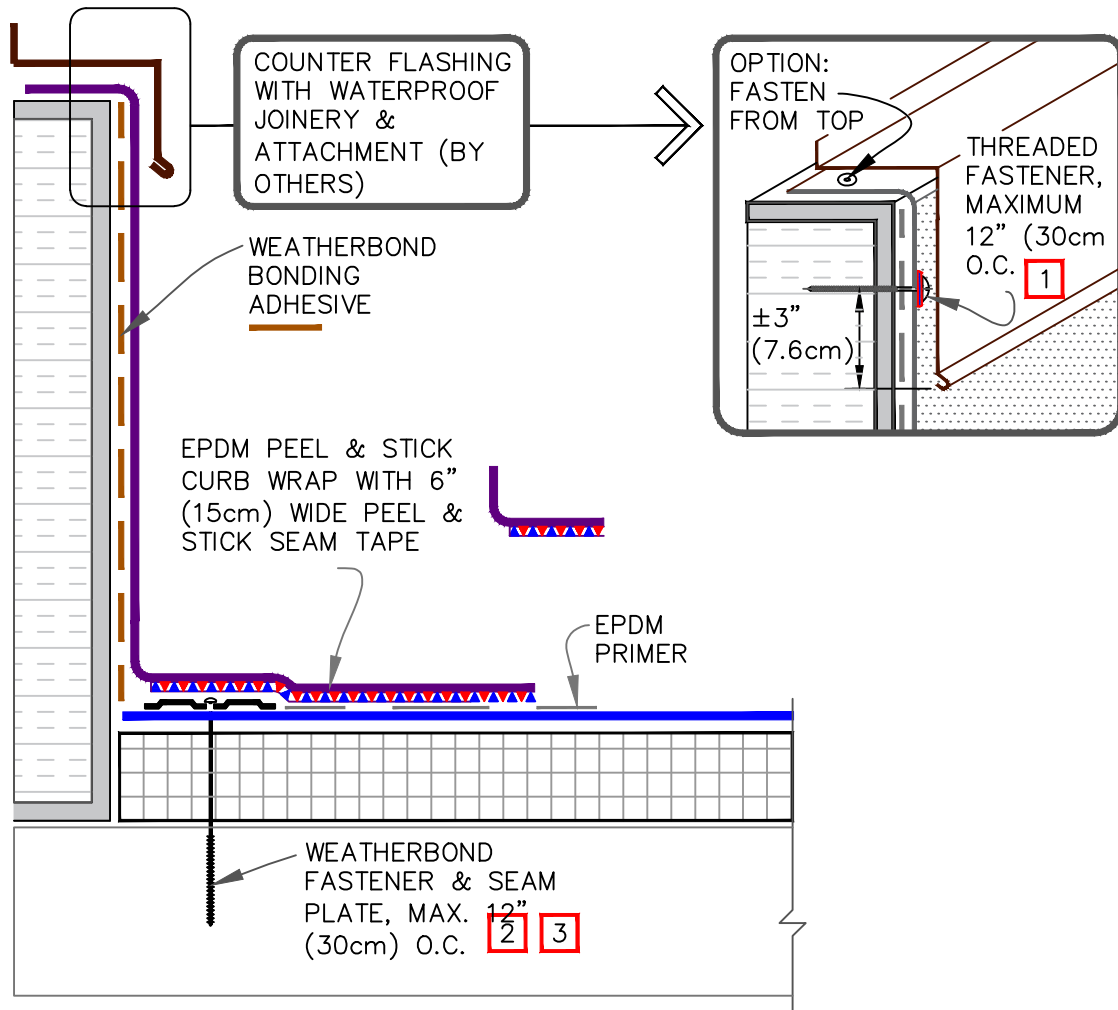

NOTES:

1. IN CASE THE THREADED FASTENERS ARE USED TO PENETRATE THE METAL COUNTER-FLASHING, USE EPDM WASHERS, APPLY WATER CUT-OFF MASTIC UNDER THE COUNTER-FLASHING OR SEAL THE FASTENER HEADS WITH SEALANT.
2. SEAM PLATES AND FASTENERS MAY BE INSTALLED INTO THE VERTICAL SUBSTRATE.
3. HPWX FASTENERS AND POLYMER SEAM PLATES ARE REQUIRED FOR MECHANICALLY FASTENED SYSTEMS OVER STEEL DECKS.
4. IF THE VERTICAL SPLICE ON THE CURB FLASHING IS NOT LOCATED AT THE CORNER, USE DETAIL [WBRC-2.3](#) FOR EPDM MEMBRANE SPLICES AT ANGLE CHANGES.

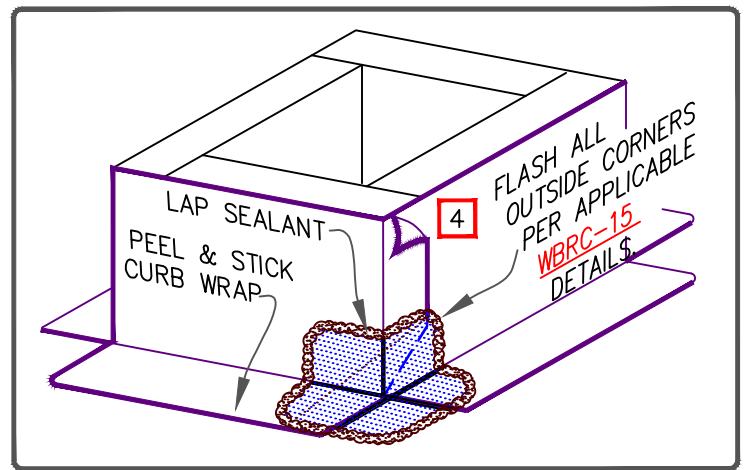

PEEL & STICK CURB WRAP

- EPDM MEMBRANE
- APPROVED SUBSTRATE
- SEE NOTE

EPDM ROOFING SYSTEM

WBRC-5.2

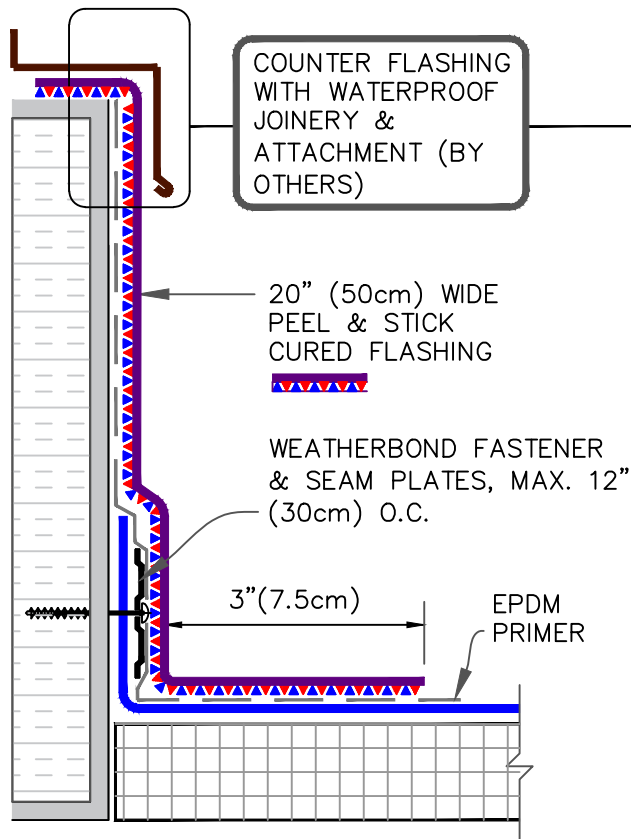

FASTENERS INTO CURB

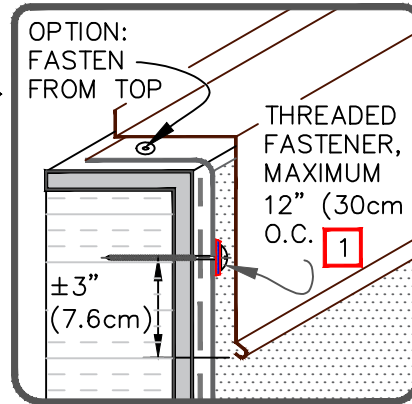

WEATHERBOND FASTENER & SEAM PLATES, MAX. 12" (30cm) O.C.

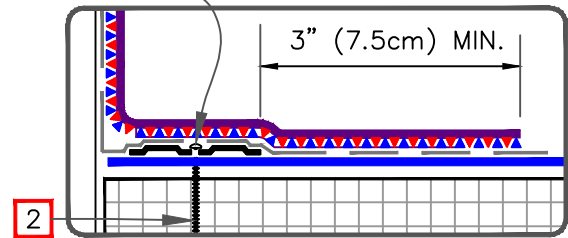

FASTENERS INTO DECK

NOTES:

1. IN CASE THE THREADED FASTENERS ARE USED TO PENETRATE THE METAL COUNTER-FLASHING, USE EPDM WASHERS, APPLY WATER CUT-OFF MASTIC UNDER THE COUNTER-FLASHING OR SEAL THE FASTENER HEADS WITH SEALANT.
2. HPWX FASTENERS AND POLYMER SEAM PLATES ARE REQUIRED FOR MECHANICALLY-FASTENED ROOFING SYSTEMS OVER STEEL DECKS.
3. IF THE VERTICAL SPLICE ON THE CURB FLASHING IS NOT LOCATED AT THE CORNER, USE DETAIL [WBRC-2.3](#) FOR EPDM MEMBRANE SPLICES AT ANGLE CHANGES.

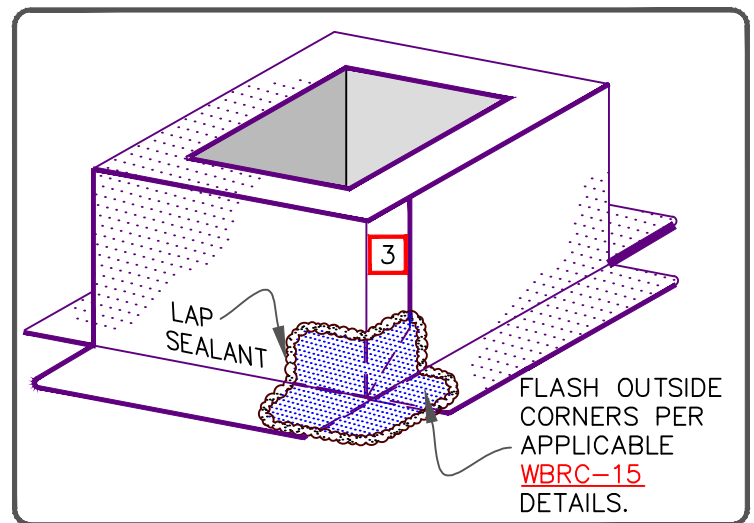

SELF-FLASHING CURB

- EPDM MEMBRANE
- APPROVED SUBSTRATE
- SEE NOTE

EPDM ROOFING SYSTEM

WBRC-5.3

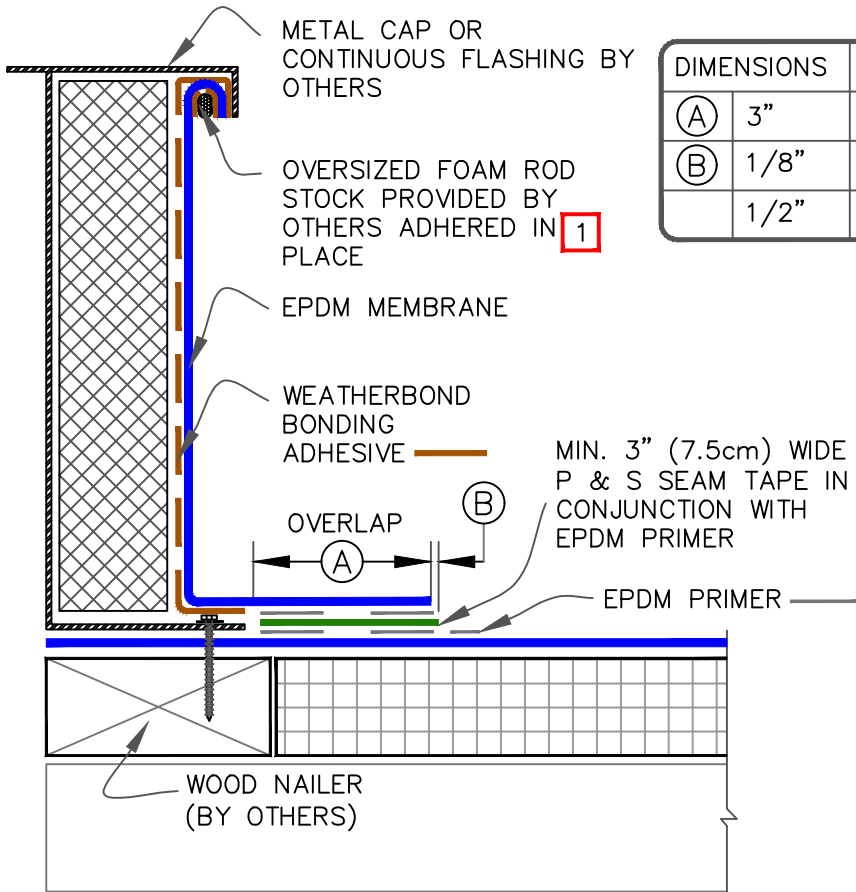

DIMENSIONS		cm	
(A)	3"	7.5	APPROX.
(B)	1/8"	0.5	MIN.
	1/2"	1.5	MAX.

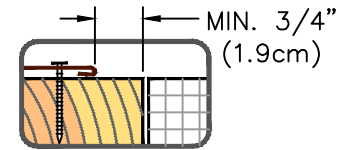

NOTES:

1. LENGTH OF ROD STOCK IS LIMITED TO 4' (1.2m). USE INDIVIDUAL SECTIONS OF ROD STOCK FOR LONGER DIMENSIONS.
2. WHEN METAL FLANGE IS ON TOP OF MEMBRANE USE DETAIL [WBRC-15.6](#) (20 YEAR) OR [WBRC-15.7A](#) (25/30 YEAR) TO ACHIEVE SUFFICIENT COVERAGE AT THE CORNERS.
3. DETAIL IS NOT ACCEPTABLE FOR VIBRATING ROOF TOP UNITS.

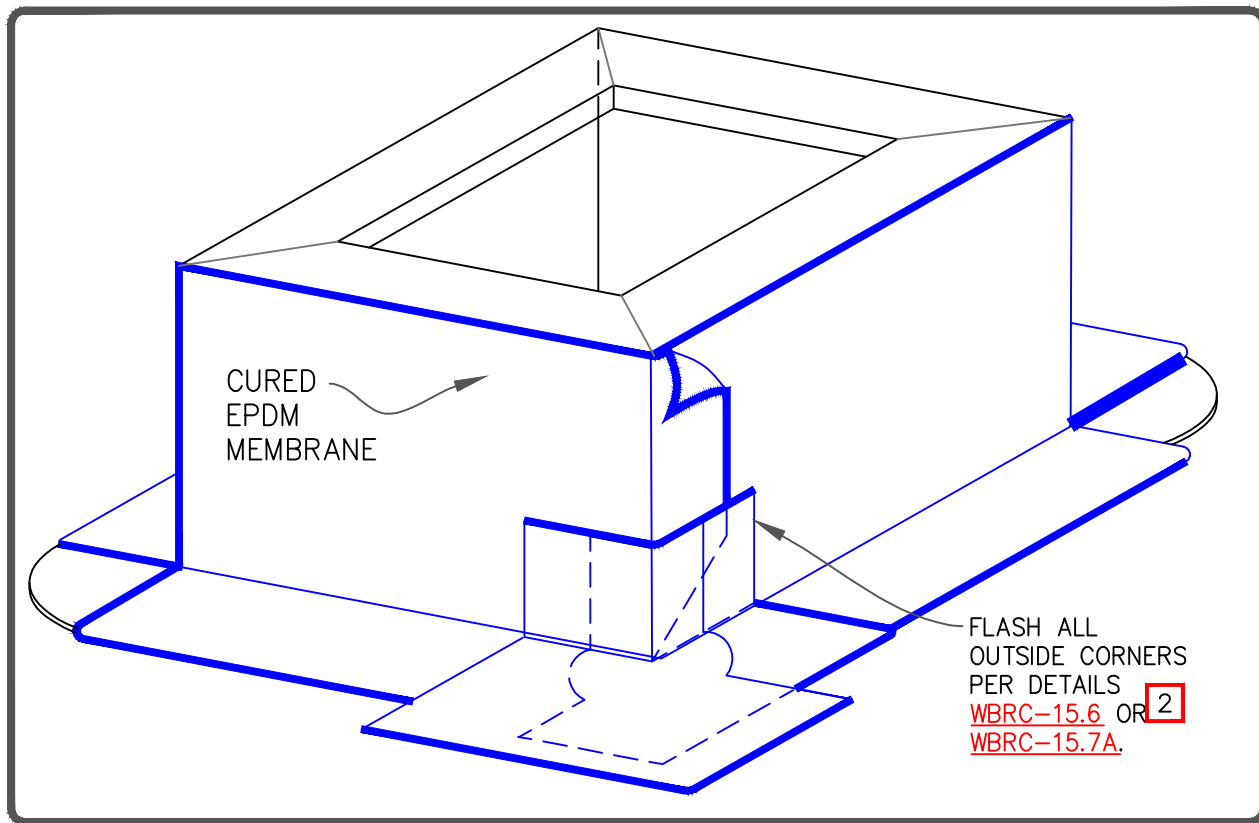

NEW SELF-FLASHING METAL CURB

- EPDM MEMBRANE
- APPROVED SUBSTRATE
- SEE NOTE

EPDM ROOFING SYSTEM

WBRC-5.4

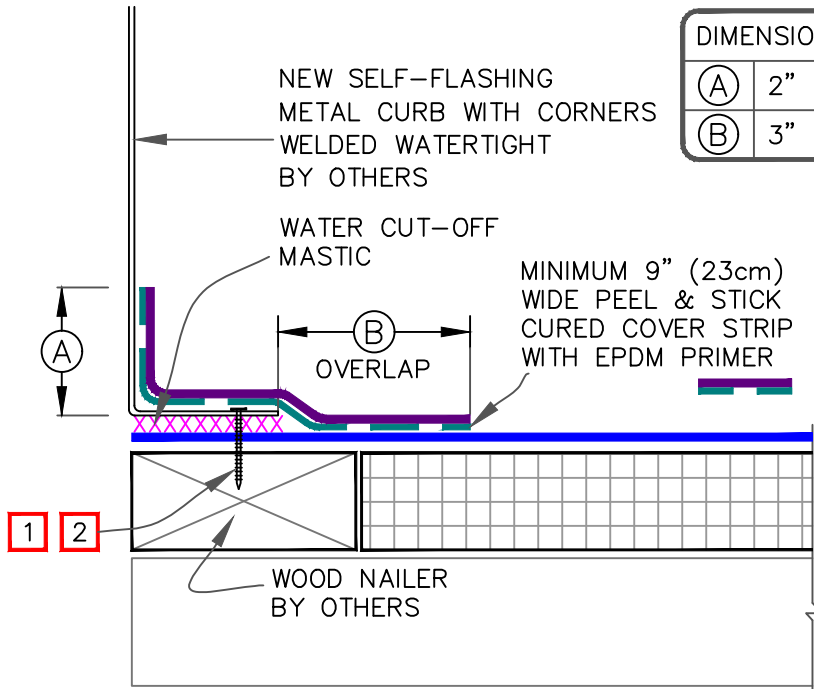

DIMENSIONS		cm	
(A)	2"	5	MIN.
(B)	3"	7.5	APPROX.

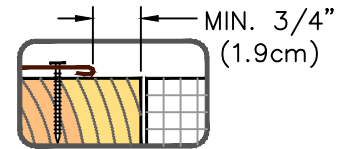

NOTES:

1. CONSULT THE RESPECTIVE MANUFACTURER OF THE SELF-FLASHING METAL CURB FOR PROPER SECUREMENT.
2. WATER CUT-OFF MASTIC MUST BE HELD UNDER CONSTANT COMPRESSION.
3. USE [DETAIL WBRC-15.6](#) TO ACHIEVE SUFFICIENT COVERAGE OF METAL FLANGE AT CORNERS.
4. IF THE VERTICAL SPLICE ON THE CURB FLASHING IS NOT LOCATED AT THE CORNER, USE [DETAIL WBRC-2.3](#) FOR EPDM MEMBRANE SPLICES AT ANGLE CHANGES.

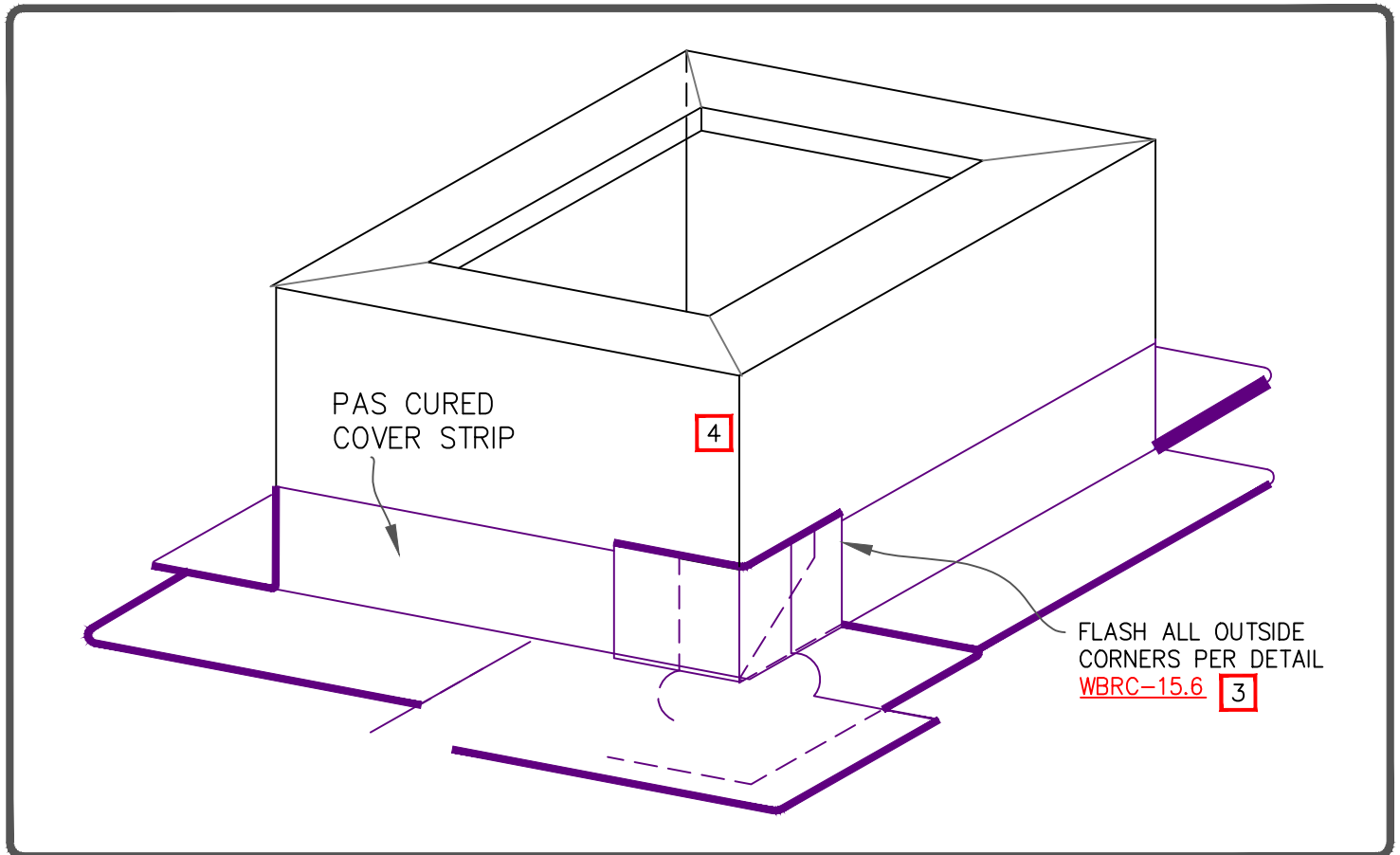

SELF-FLASHING CURB, ROOF HATCH, OR SKYLIGHT

- EPDM MEMBRANE
- APPROVED SUBSTRATE
- SEE NOTE

EPDM ROOFING SYSTEM
WBRC-5.5

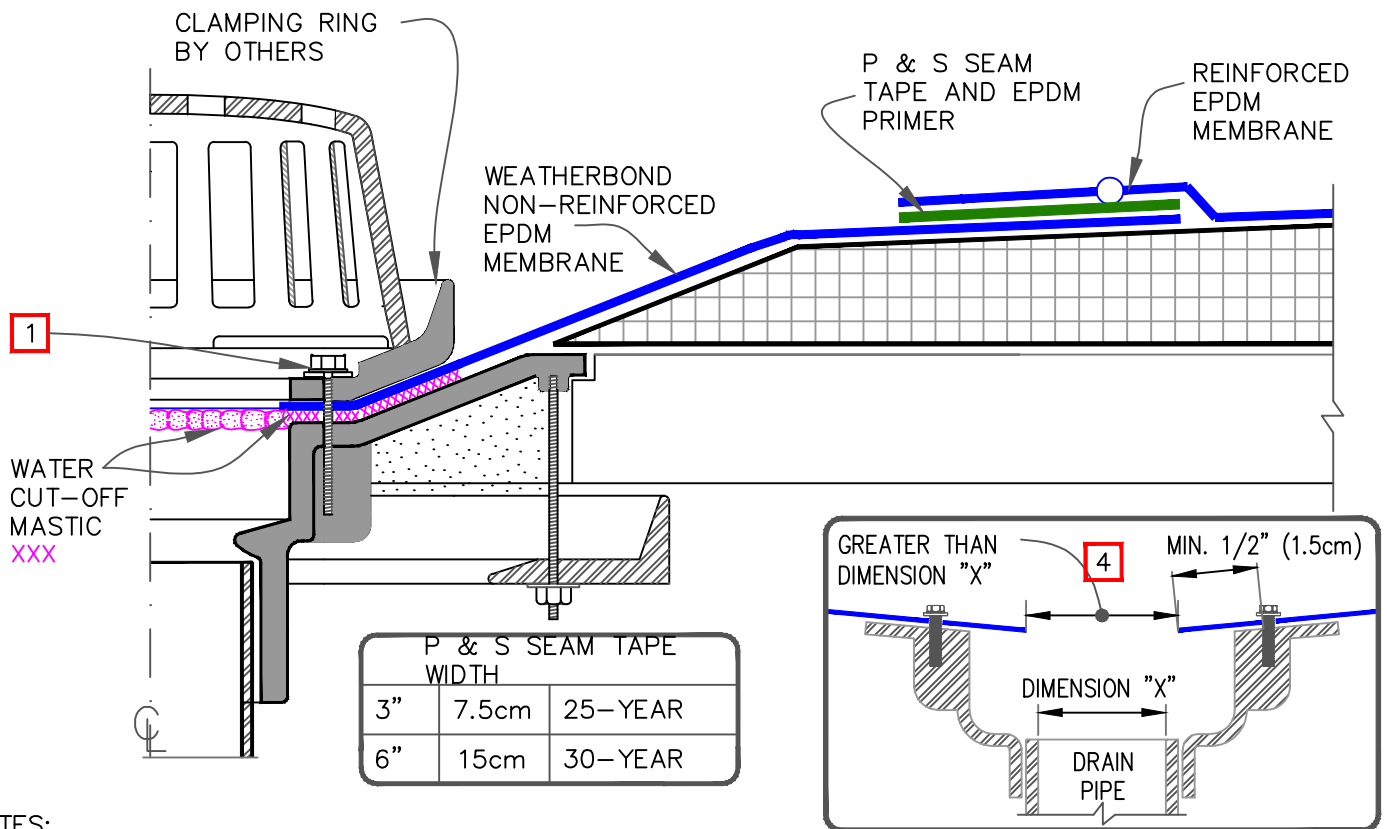



NOTES:

1. ALL BOLTS OR CLAMPS MUST BE IN PLACE TO PROVIDE CONSTANT COMPRESSION ON WATER CUT-OFF MASTIC.
2. REMOVE EXISTING LEAD, FLASHING MATERIAL & ENSURE THE DRAIN RING IS COMPLETELY CLEAN DOWN TO BARE METAL.
3. USE DETAIL [WBRMA-6.0](#) FOR MECHANICALLY-FASTENED SYSTEMS.
4. THE HOLE IN THE MEMBRANE SHALL EXCEED THE DIAMETER OF THE DRAIN PIPE, BUT SHALL BE NO LESS THAN 1/2" (1.5cm) FROM THE ATTACHMENT POINTS OF THE DRAIN CLAMPING RING.
5. ROOF DRAIN SIZE AND NUMBER OF DRAINS SHALL BE IN ACCORDANCE WITH THE LOCAL CODES.
6. FIELD SPLICES MUST BE LOCATED AT LEAST 6" (15cm) OUTSIDE THE DRAIN SUMP.
7. WEATHERBOND RECOMMENDS THE DRAIN TARGET SPLICE BE SHINGLED
 - 7.1. CUT A SQUARE HOLE IN THE FIELD SHEET TO BE AT LEAST 6" (15cm) OUTSIDE THE DRAIN SUMP
 - 7.2. APPLY PRIMER AND P & S SEAM TAPE TO THE BOTTOM OF THE FIELD SHEET
 - 7.3. PRIME THE TARGET PIECE OF NON-REINFORCED EPDM
 - 7.4. MATE THE TARGET TO THE TAPE
 - 7.5. APPLY BONDING ADHESIVE TO ADHERE FIELD AND TARGET MEMBRANE TO THE SUBSTRATE



ROOF DRAIN – REINFORCED FIELD SHEET WITH SUMP EXCEEDING 3" PER FOOT

-  EPDM MEMBRANE
-  APPROVED SUBSTRATE
-  SEE NOTE

EPDM ROOFING SYSTEM

WBRC-6.2

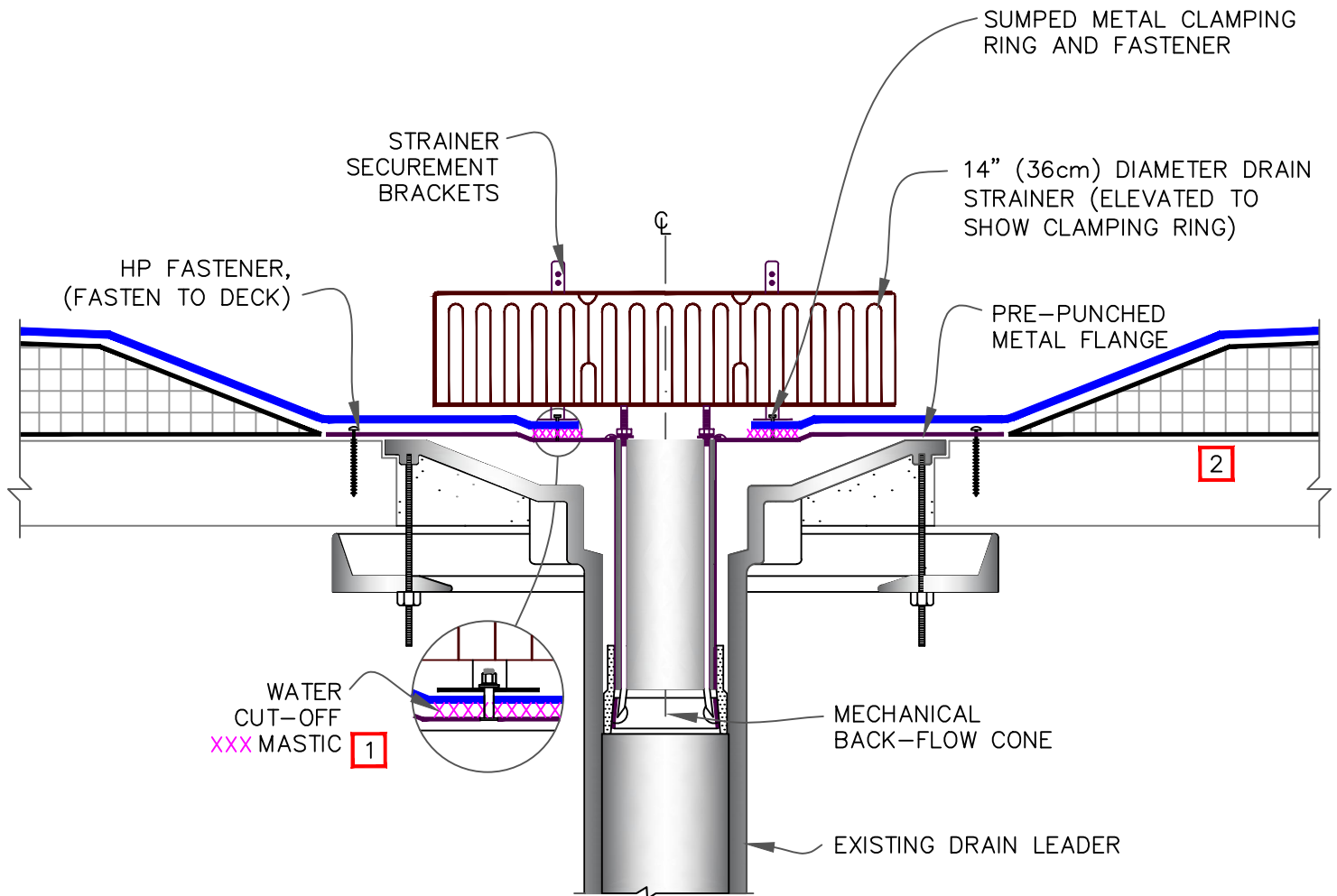

NOTES:

1. ALL BOLTS OR CLAMPS MUST BE IN PLACE TO PROVIDE CONSTANT COMPRESSION ON WATER CUT-OFF MASTIC.
2. INSULATION TAPER SHALL NOT BE GREATER THAN 6" (15cm) IN 12" (30cm) HORIZONTAL.
3. THE HOLE IN THE MEMBRANE SHALL EXCEED THE DIAMETER OF THE DRAIN PIPE, BUT SHALL BE NO LESS THAN 1/2" (1.5cm) FROM THE ATTACHMENT POINTS OF THE DRAIN CLAMPING RING.
4. FIELD SPLICES MUST BE LOCATED AT LEAST 6" (15cm) OUTSIDE THE DRAIN SUMP.
5. ROOF DRAIN SIZE AND NUMBER OF DRAINS SHALL BE IN ACCORDANCE WITH THE LOCAL CODES.

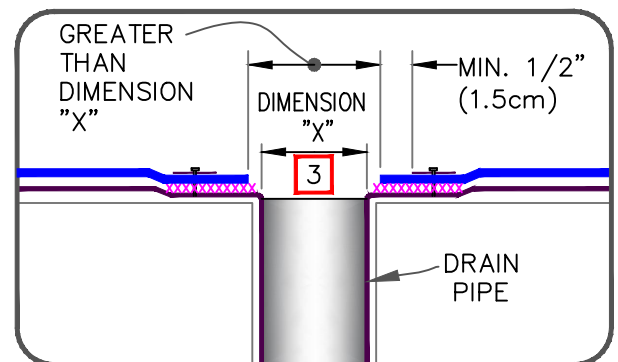

INSERT DRAIN

- EPDM MEMBRANE
- APPROVED SUBSTRATE
- SEE NOTE

EPDM ROOFING SYSTEM
WBRC-6.3

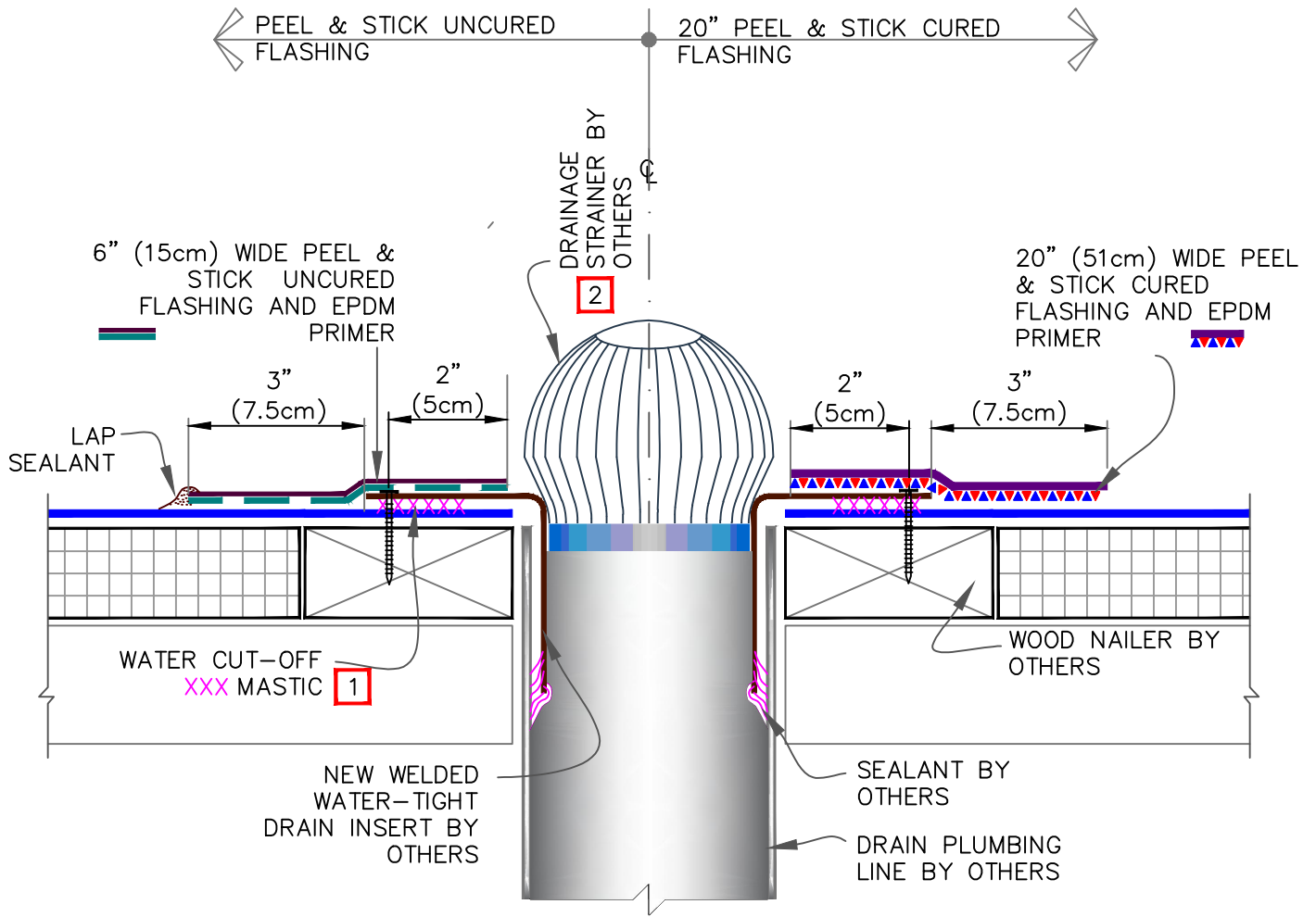

NOTES:

1. WATER CUT-OFF MASTIC MUST BE UNDER CONSTANT COMPRESSION.
2. CONSULT SPECIFIER OR APPLICABLE CODES FOR ADEQUATE DRAINAGE STRAINER TO AVOID PONDING WATER. DO NOT RESTRICT WATER FLOW.



INSERT DRAIN THROUGH DECK

- EPDM MEMBRANE
- APPROVED SUBSTRATE
- 0 SEE NOTE

EPDM ROOFING SYSTEM

WBRC-6.4

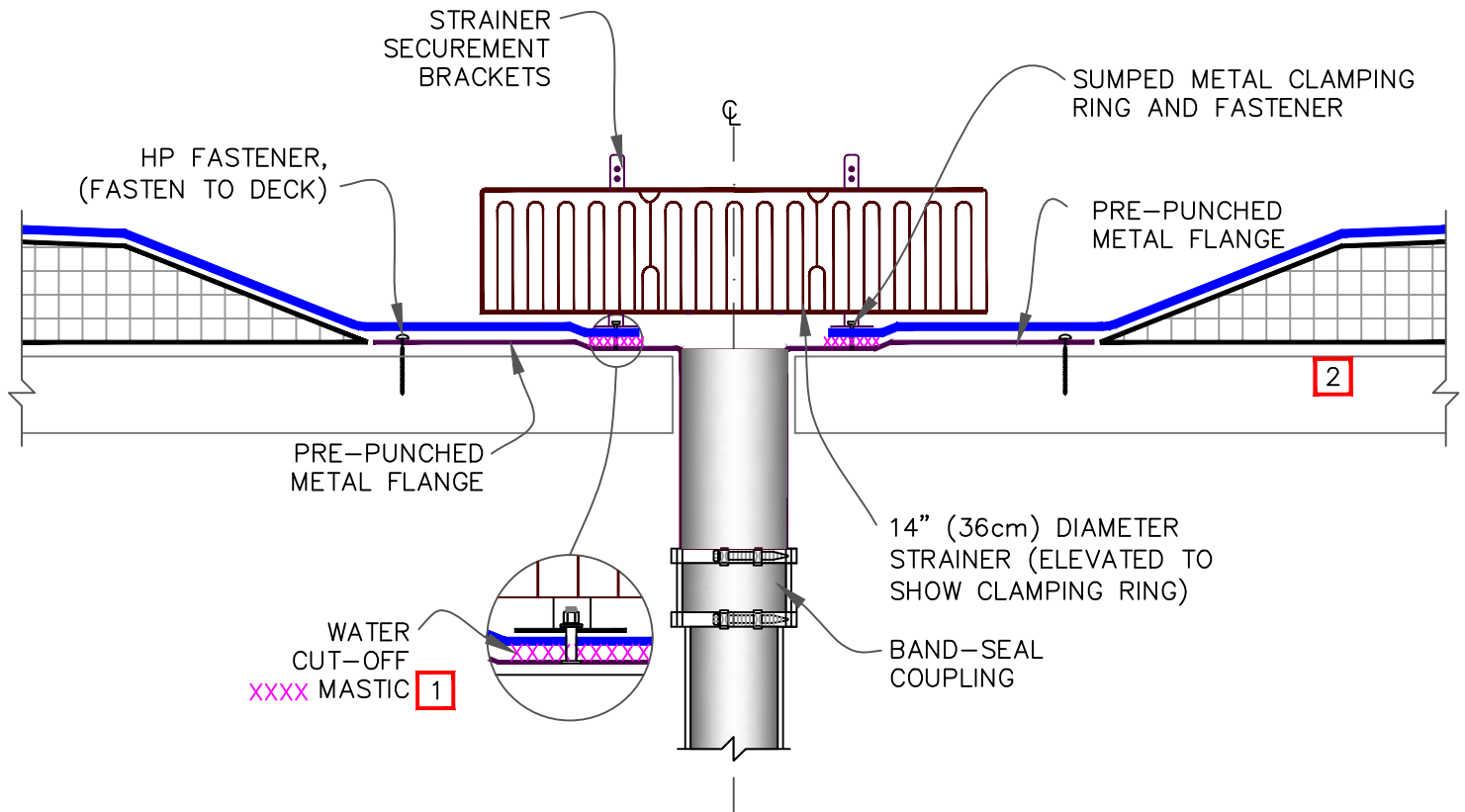

NOTES:

1. ALL BOLTS OR CLAMPS MUST BE IN PLACE TO PROVIDE CONSTANT COMPRESSION ON WATER CUT-OFF MASTIC.
2. INSULATION TAPER SHALL NOT BE GREATER THAN 6" (15cm) IN 12" (30cm) HORIZONTAL.
3. THE HOLE IN THE MEMBRANE SHALL EXCEED THE DIAMETER OF THE DRAIN PIPE, BUT SHALL BE NO LESS THAN 1/2" (1.5cm) FROM THE ATTACHMENT POINTS OF THE DRAIN CLAMPING RING.
4. FIELD SPLICES MUST BE LOCATED AT LEAST 6" (15cm) OUTSIDE THE DRAIN SUMP.
5. ROOF DRAIN SIZE AND NUMBER OF DRAINS SHALL BE IN ACCORDANCE WITH THE LOCAL CODES.

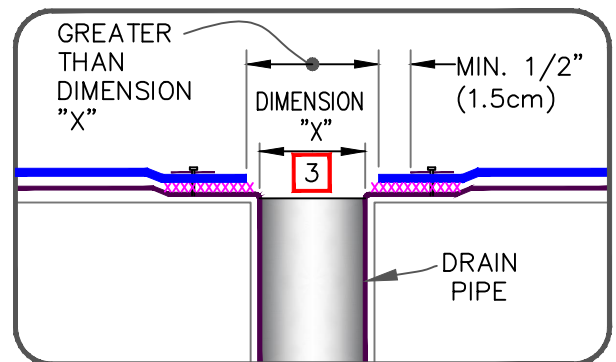

ADD-ON DRAIN

- EPDM MEMBRANE
- APPROVED SUBSTRATE
- SEE NOTE

EPDM ROOFING SYSTEM
WBRC-6.5

NOTES:

1. REMOVE ALL LEAD AND OTHER FLASHING BEFORE INSTALLING PEEL & STICK PIPE SEAL.
2. TEMPERATURE OF PIPE PENETRATION MUST NOT EXCEED 180°F (82°C).
3. PRE-MOLDED PIPE FLASHING MUST HAVE RIB INTACT AT THE TOP EDGE REGARDLESS OF PIPE DIAMETER.
4. DECK FLANGES OF THE PEEL & STICK PIPE SEAL SHALL NOT BE OVERLAPPED, CUT OR APPLIED OVER ANY ANGLE CHANGE.
5. ON MECHANICALLY-FASTENED ROOFING SYSTEMS, REFER TO [DETAIL WBRMA-8.1](#)

DIMENSIONS		cm	
(A)	1/2"	1.5	TO
	6"	15	
(B)	3"	7.5	

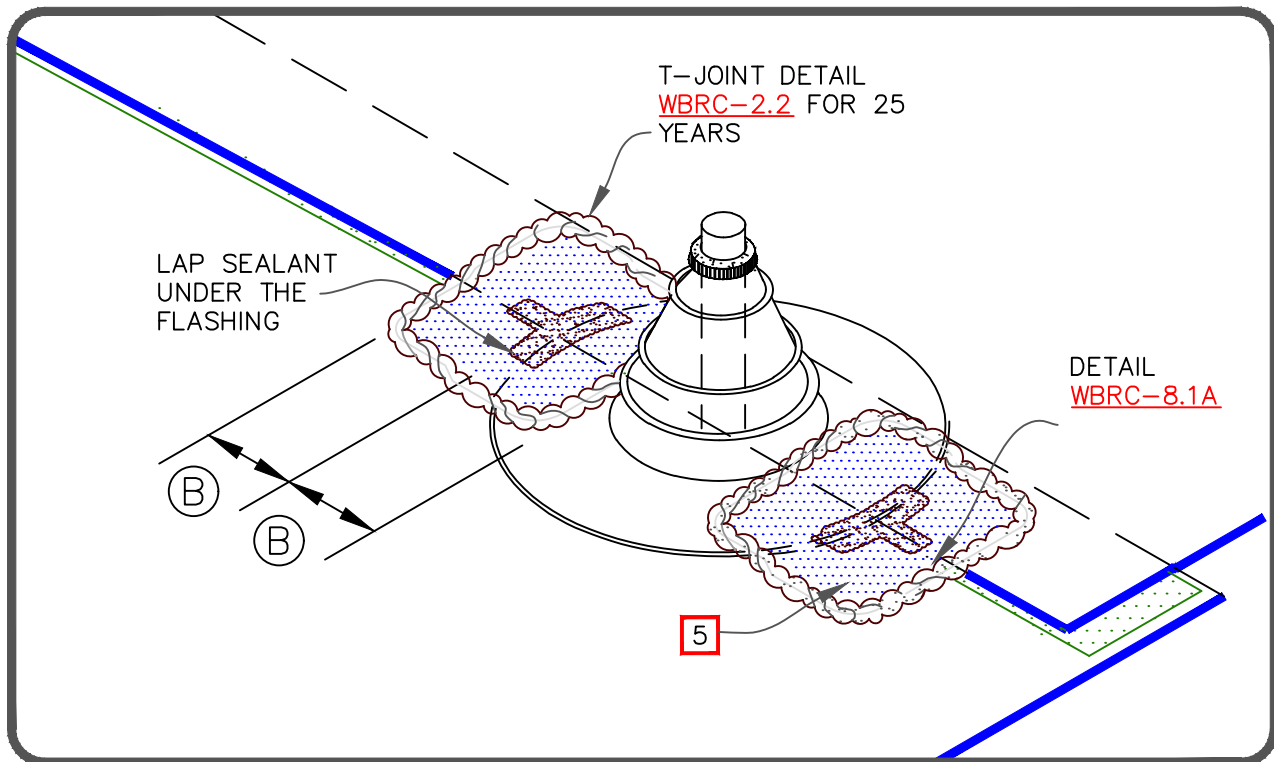
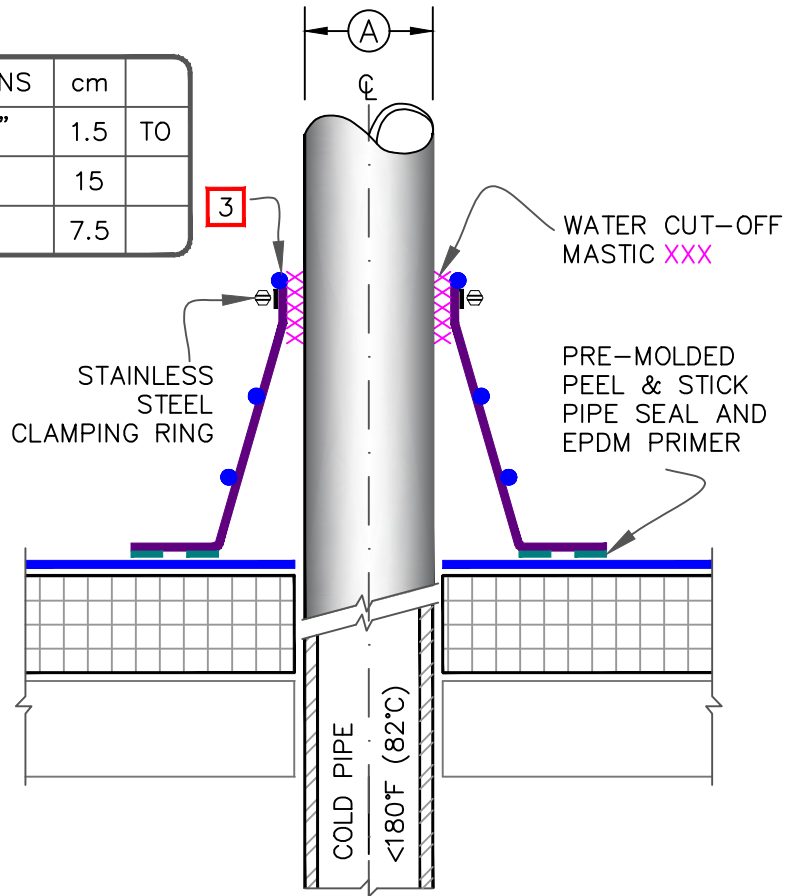

PEEL & STICK PIPE SEAL

- EPDM MEMBRANE
- APPROVED SUBSTRATE
- SEE NOTE

EPDM ROOFING SYSTEM

WBRC-8.1A

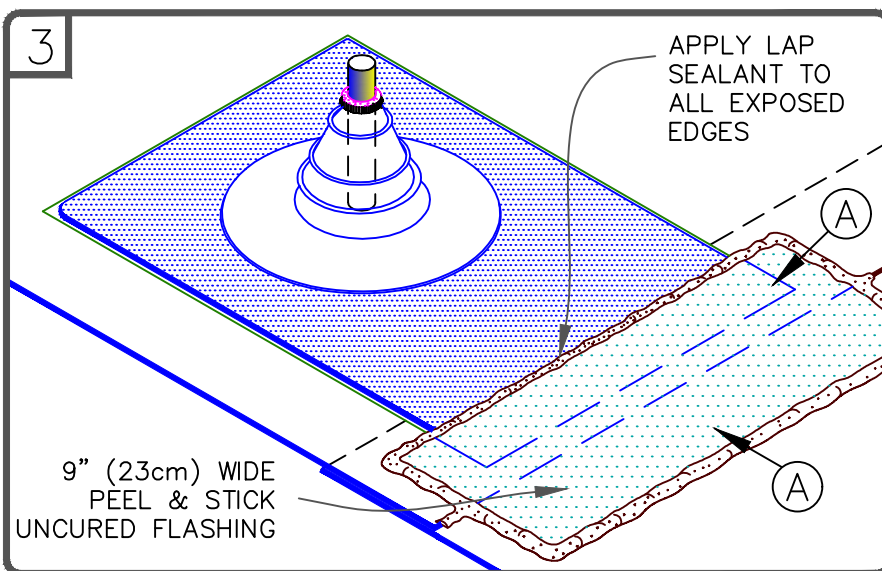
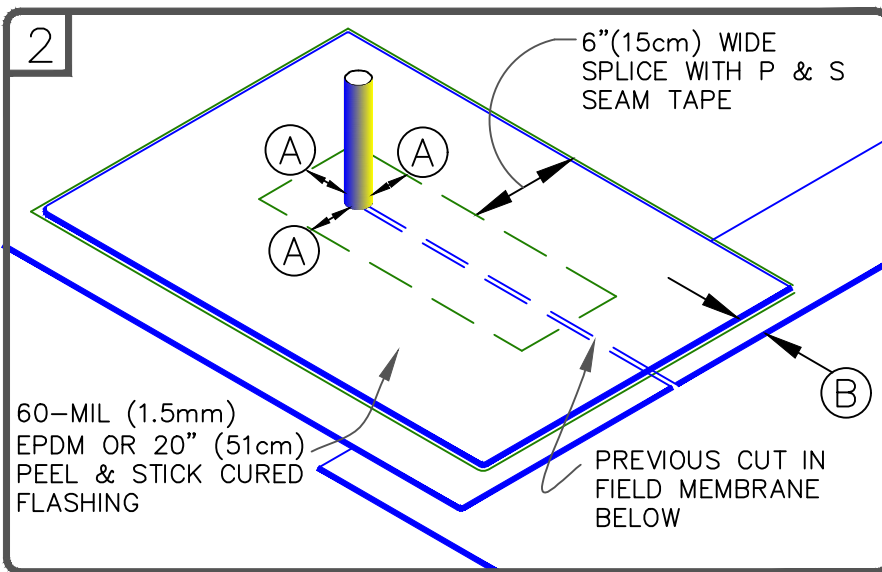
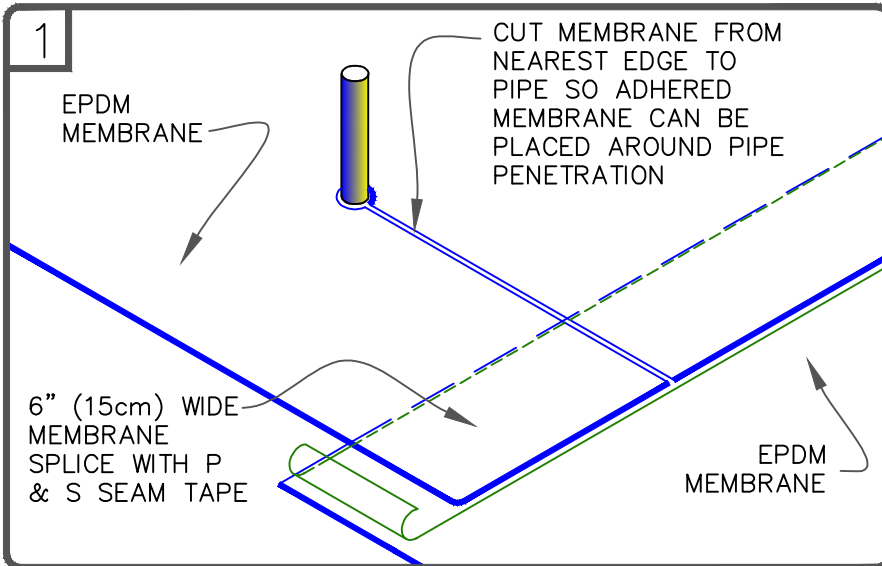

NOTES:

1. THIS DETAIL FOR USE WHEN A RELIEF CUT OR MEMBRANE SPLICE IS PRESENT AT THE PIPE SEAL. USE DETAIL [WBRC-8.1](#) WHEN NO CUT OR SPLICE IS PRESENT.
2. REMOVE ALL LEAD AND OTHER FLASHING BEFORE INSTALLING PEEL & STICK PIPE SEAL.
3. PIPE SEAL MUST HAVE INTACT RIB AT TOP EDGE, REGARDLESS OF PIPE DIAMETER.
4. DECK FLANGES OF THE MOLDED PIPE SEAL SHALL NOT BE OVERLAPPED, CUT OR APPLIED OVER ANY ANGLE CHANGE.
5. ON MECHANICALLY FASTENED ROOFING SYSTEMS REFER TO DETAIL [WBRMA-8.3](#).

DIMENSIONS		cm	
(A)	3"	7.5	MIN.
(B)	1"	2.5	MIN.



PRE-MOLDED PEEL & STICK PIPE SEAL WITH 90-MIL MEMBRANE

- EPDM MEMBRANE
- APPROVED SUBSTRATE
- SEE NOTE

EPDM ROOFING SYSTEM

WBRC-8.1B

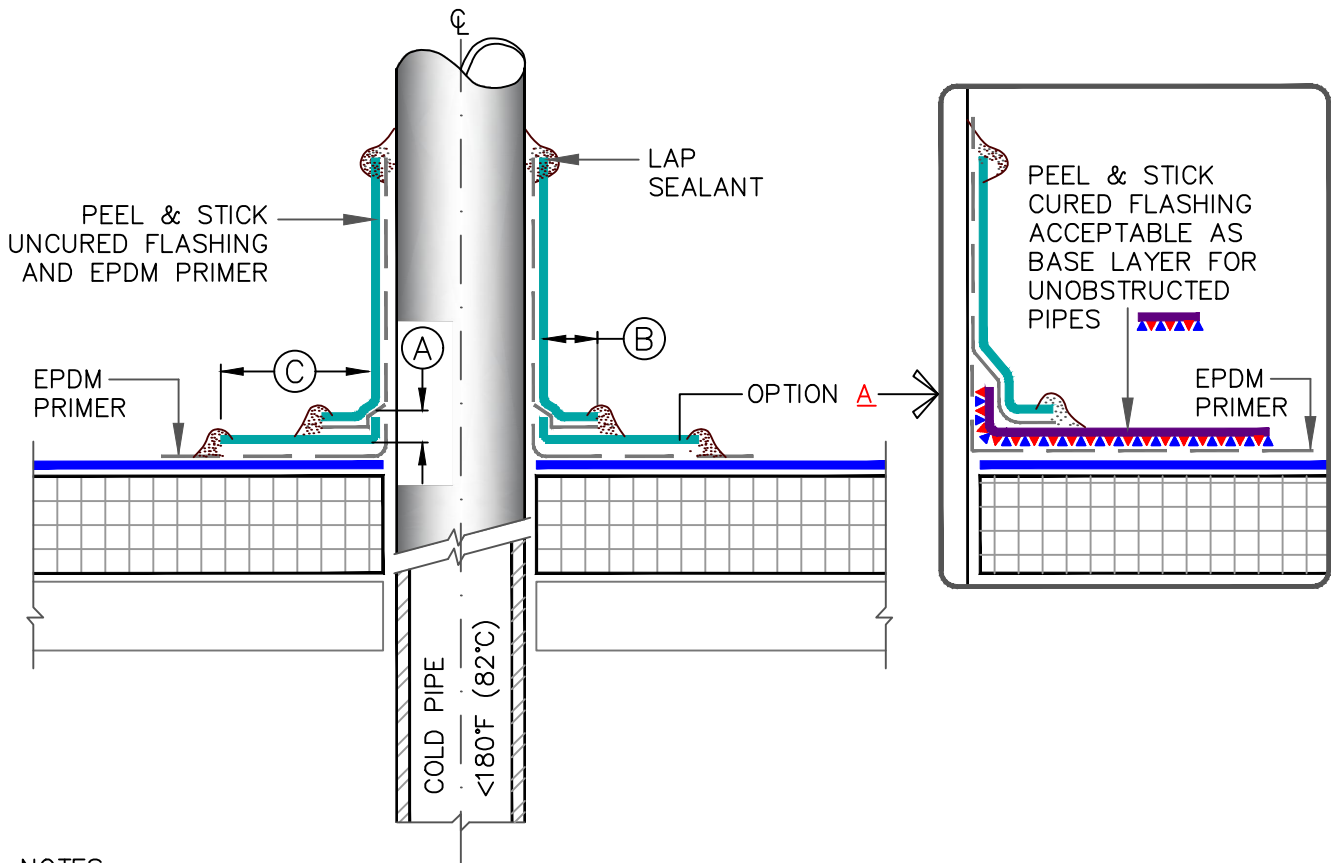

NOTES:

1. REMOVE ALL LEAD AND OTHER FLASHING BEFORE INSTALLING FIELD-FABRICATED FLASHING.
2. TEMPERATURE OF PIPE PENETRATION MUST NOT EXCEED 180°F (82°C).
3. ACCEPTABLE WITH SQUARE OR RECTANGULAR STRUCTURAL TUBING WITH ROUNDED CORNERS UP TO 12”(30cm). USE [DETAIL WBRC-5](#) IF GREATER THAN 12” (30cm).
4. IN COLDER TEMPERATURES, A HEAT GUN MUST BE USED WHEN FORMING PEEL & STICK UNCURED EPDM OR CURED FLASHING.
5. ON MECHANICALLY FASTENED ROOFING SYSTEMS. REFER TO [DETAIL WBRMA-8.2](#).
6. MEMBRANE SECUREMENT IS REQUIRED AROUND ALL ROUND PIPE PENETRATIONS GREATER THAN 18” (46cm) IN DIAMETER.

DIMENSIONS		cm	
(A)	1/2”	1.5	MIN.
(B)	1”	2.5	MIN.
(C)	3”	7.5	MIN.



FIELD FABRICATED PIPE SEAL

- EPDM MEMBRANE
- APPROVED SUBSTRATE
- SEE NOTE

EPDM ROOFING SYSTEM

WBRC-8.2

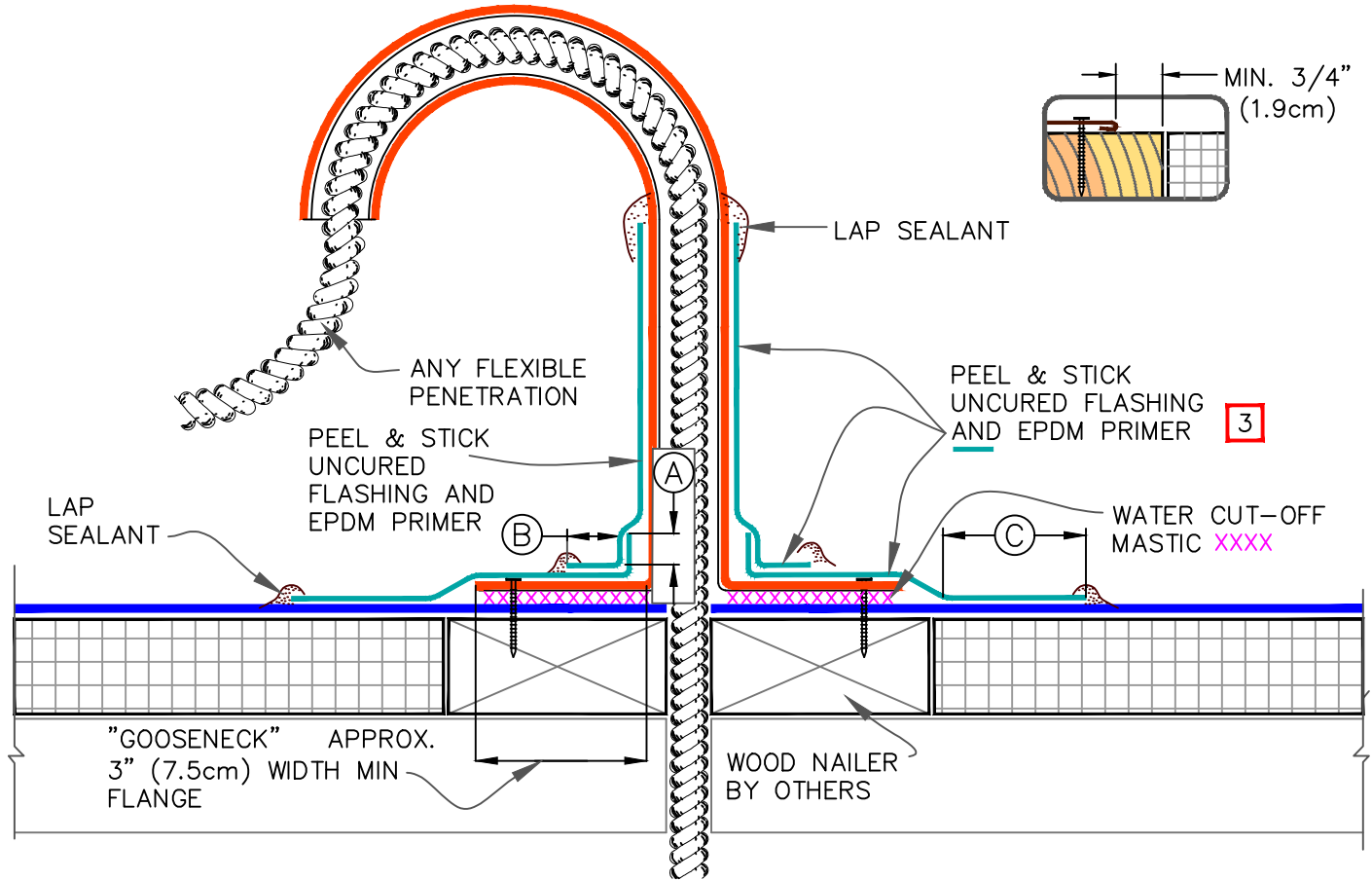

NOTES:

1. REMOVE ALL LEAD AND OTHER FLASHING BEFORE INSTALLING FIELD-FABRICATED PIPE SEAL.
2. TEMPERATURE OF PENETRATION MUST NOT EXCEED 180°F (82°C).
3. IN COLDER TEMPERATURES, A HEAT GUN MUST BE USED WHEN FORMING PEEL & STICK UNCURED FLASHING.

DIMENSIONS		cm	
(A)	1/2"	1.5	MIN.
(B)	1"	2.5	MIN.
(C)	3"	7.5	MIN.



FLEXIBLE PENETRATION

- EPDM MEMBRANE
- APPROVED SUBSTRATE
- SEE NOTE

EPDM ROOFING SYSTEM
WBRC-8.3

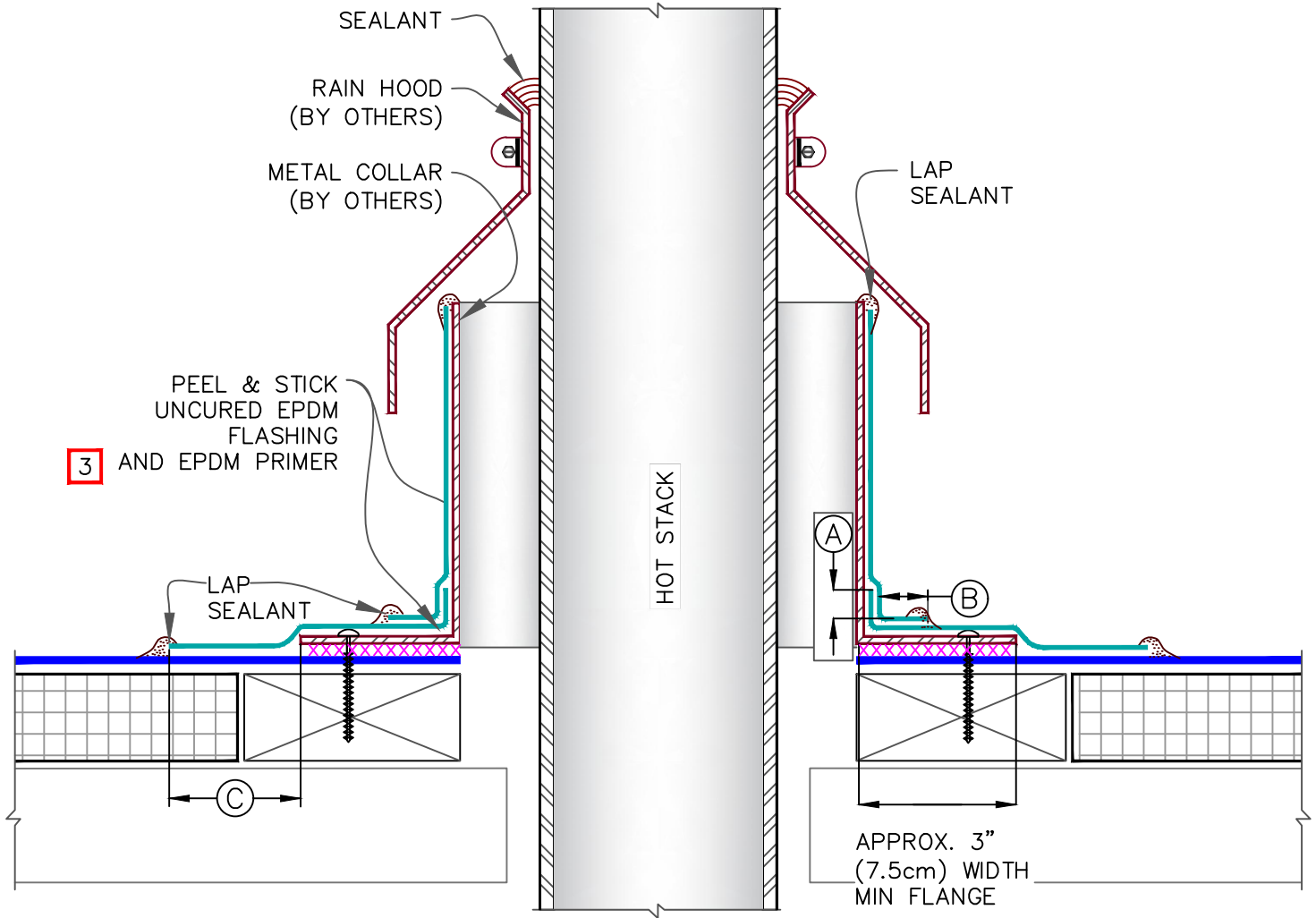

NOTES:

1. REMOVE ALL LEAD AND OTHER FLASHING BEFORE INSTALLING FIELD FABRICATED PIPE SEAL.
2. TEMPERATURE OF METAL COLLAR MUST NOT EXCEED 180°F (82°C).
3. IN COLDER TEMPERATURES, A HEAT GUN MUST BE USED WHEN FORMING PEEL & STICK UNCURED FLASHING.

DIMENSIONS		cm	
(A)	1/2"	1.5	MIN.
(B)	1"	2.5	MIN.
(C)	3"	7.5	MIN.



FIELD FABRICATED HOT STACK

- EPDM MEMBRANE
- APPROVED SUBSTRATE
- SEE NOTE

EPDM ROOFING SYSTEM
WBRC-8.5

9A MECHANICAL TERMINATION WITH COUNTER FLASHING

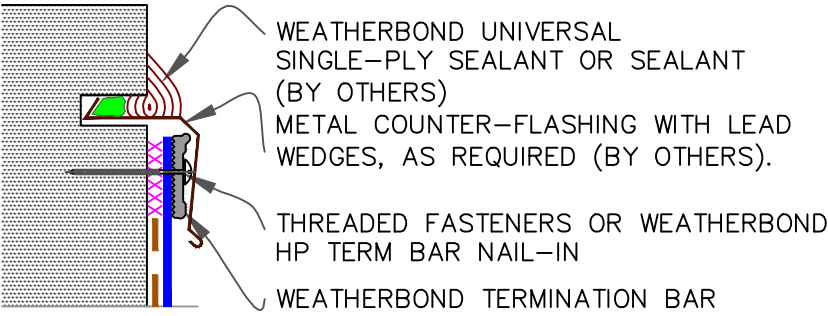

SEE INSET A

9B MECHANICAL TERMINATION

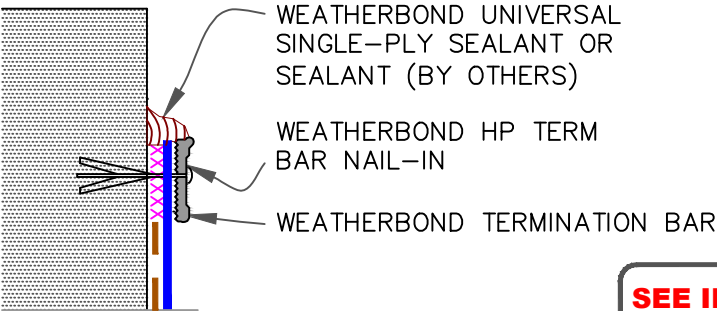

SEE INSET A

9C COUNTER FLASHING TERMINATION

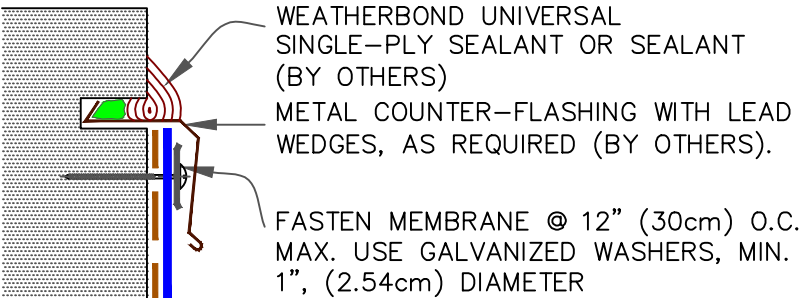

NOTE:

1. WHEN MECHANICAL FASTENERS ARE USED TO PENETRATE THE METAL COUNTER-FLASHING, USE EPDM WASHERS, APPLY WATER CUT-OFF MASTIC UNDER THE COUNTER-FLASHING OR CAULK THE FASTENER HEADS.

INSET A

MIN. 1/4" (1cm) MAX. 1/2" (1.5cm)

±1" (2.54cm)

CORNER

NOTES:

1. APPLY ON HARD SMOOTH SURFACE ONLY; NOT FOR USE ON EXPOSED WOOD.
2. DO NOT WRAP TERMINATION BAR AROUND CORNERS.
3. DETAIL [9D NEXT PAGE](#) MUST BE USED AT VERTICAL JOINTS IN PANEL WALLS.

— APPLICABLE BONDING ADHESIVE

xxx WATER CUT-OFF MASTIC— MUST BE HELD UNDER CONSTANT COMPRESSION.



MEMBRANE TERMINATION
(PAGE 1 OF 3)

- EPDM MEMBRANE
- APPROVED SUBSTRATE
- SEE NOTE

EPDM ROOFING SYSTEM
WBRC-9.0A

9D MECHANICAL TERMINATION AT VERTICAL JOINTS

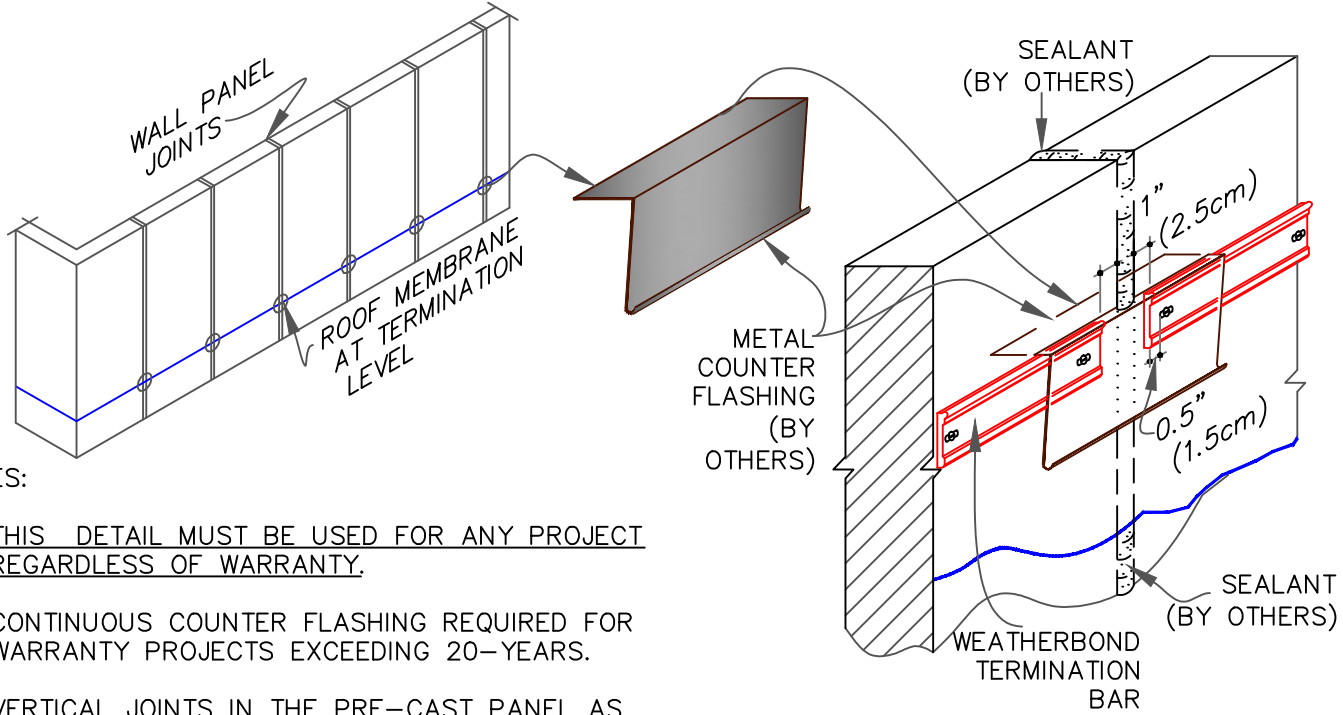

NOTES:

1. THIS DETAIL MUST BE USED FOR ANY PROJECT REGARDLESS OF WARRANTY.
2. CONTINUOUS COUNTER FLASHING REQUIRED FOR WARRANTY PROJECTS EXCEEDING 20-YEARS.
3. VERTICAL JOINTS IN THE PRE-CAST PANEL AS WELL AS ALL GAPS AT THE JUNCTION OF THE TILT-UP PANEL AND ROOF DECK MUST BE FULLY SEALED TO PREVENT AIR INFILTRATION.
4. APPLY ON HARD SMOOTH SURFACE ONLY.

9F SHEET METAL COPING (BY OTHERS)

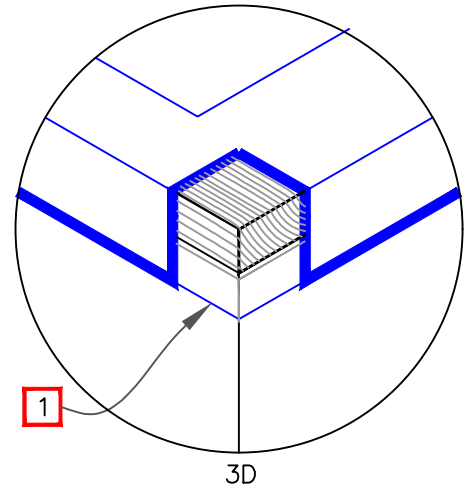
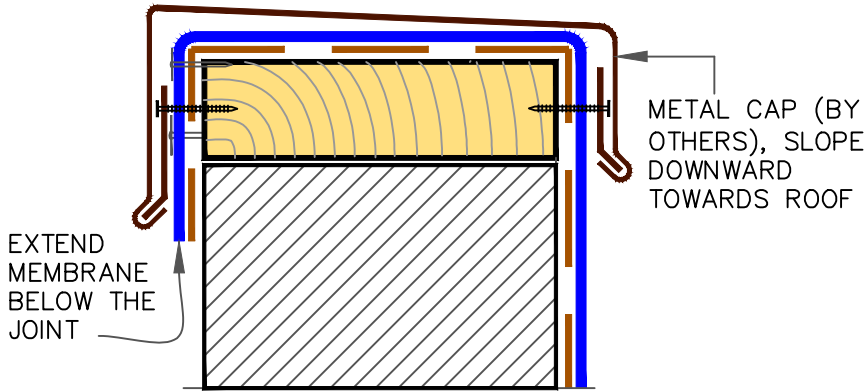

NOTES:

- MEMBRANE MUST BE EXTENDED TO CORNERS TO PROVIDE COMPLETE COVERAGE OF THE TOP WALL SURFACE.

9G MASONRY COPINGS (BY OTHERS)

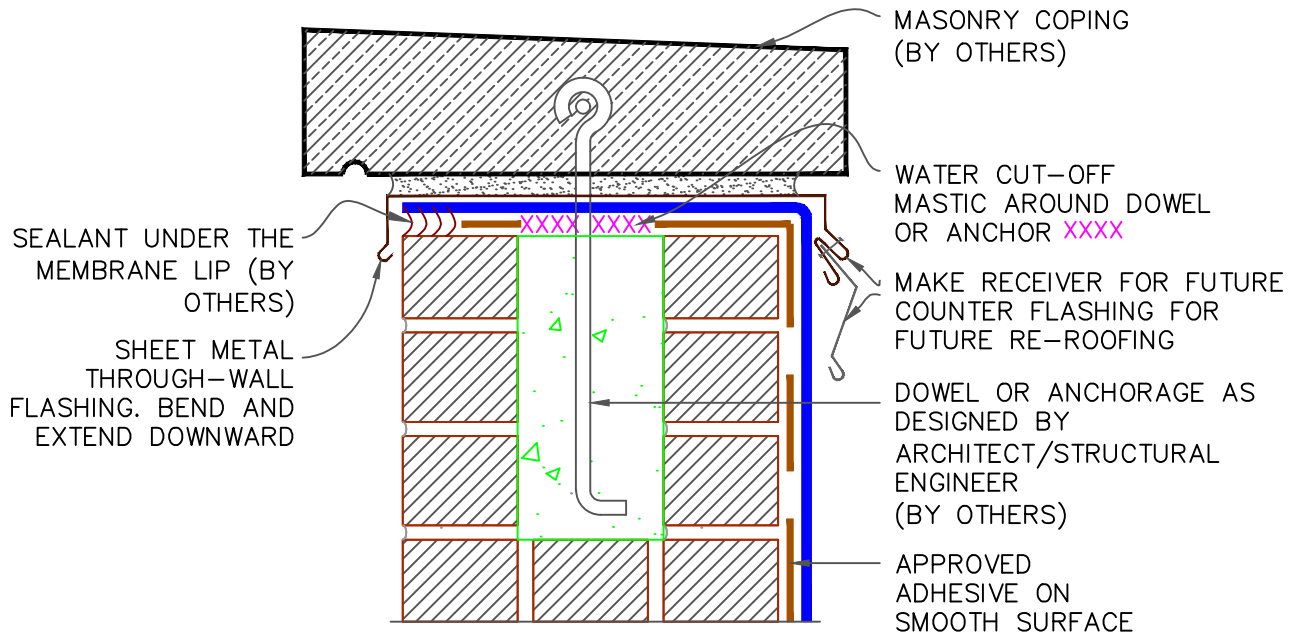

— — — — — APPLICABLE BONDING ADHESIVE

xxx WATER CUT-OFF MASTIC— MUST BE HELD UNDER CONSTANT COMPRESSION.



MEMBRANE TERMINATION
(PAGE 3 OF 3)

- EPDM MEMBRANE
- APPROVED SUBSTRATE
- SEE NOTE

EPDM ROOFING SYSTEM
WBRC-9.0C

NOTES:

- FOR CORNERS AND RPS APPLICATION REFER TO [DETAILS WBRC-15.1 OR WBRC-15.2.](#)

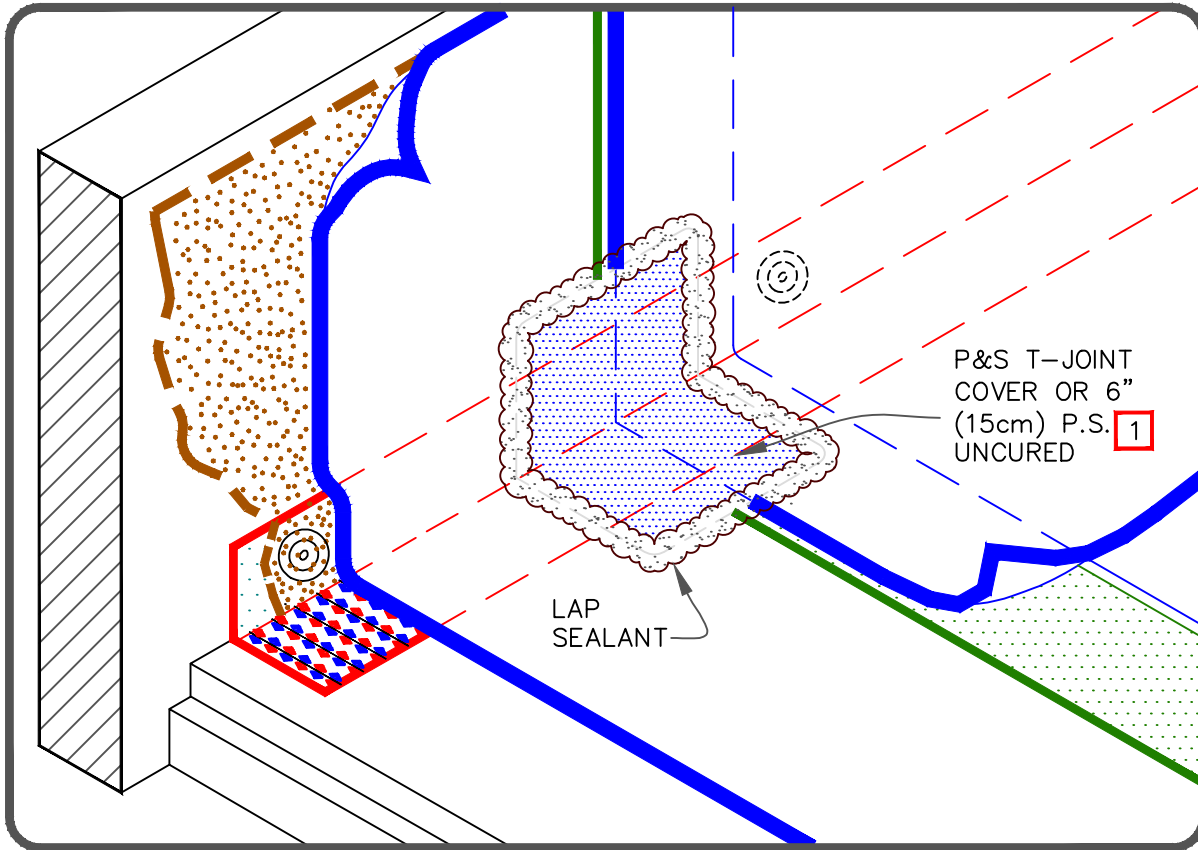
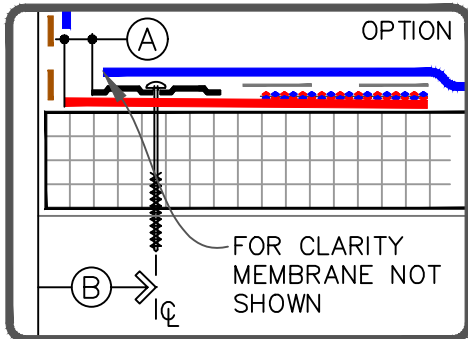
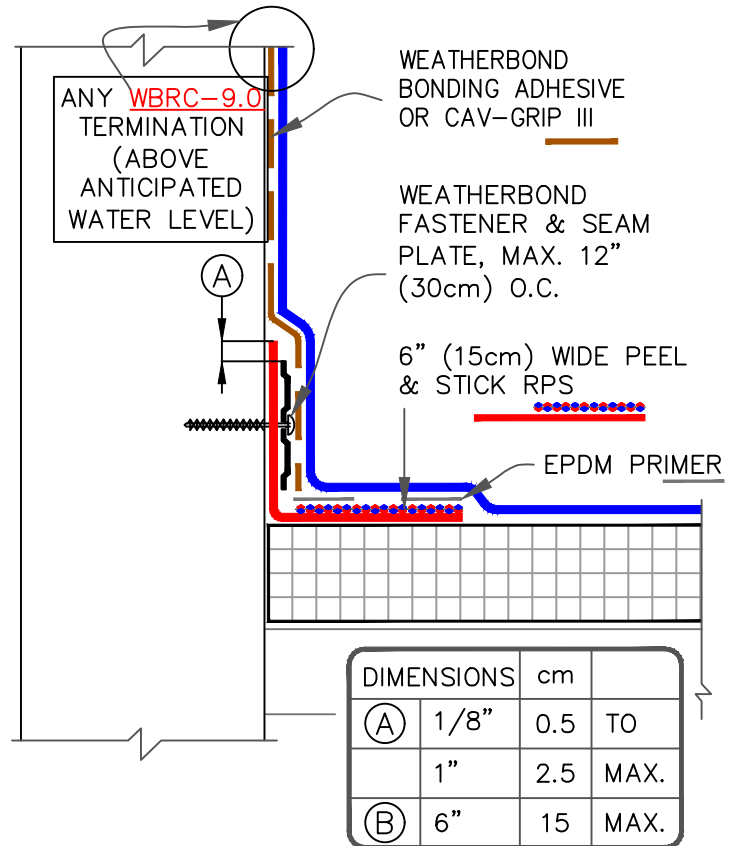

P&S (PEEL & STICK)



PARAPET / CURB WITH CONTINUOUS MEMBRANE

- EPDM MEMBRANE
- APPROVED SUBSTRATE
- SEE NOTE

EPDM ROOFING SYSTEM

WBRC-12.1

NOTES:

1. LAP SEALANT IS REQUIRED ON CUT EDGES OF REINFORCED MEMBRANE.
2. WHEN USING 90-MIL MEMBRANE, REFER TO [DETAIL WBRC-2.3](#).

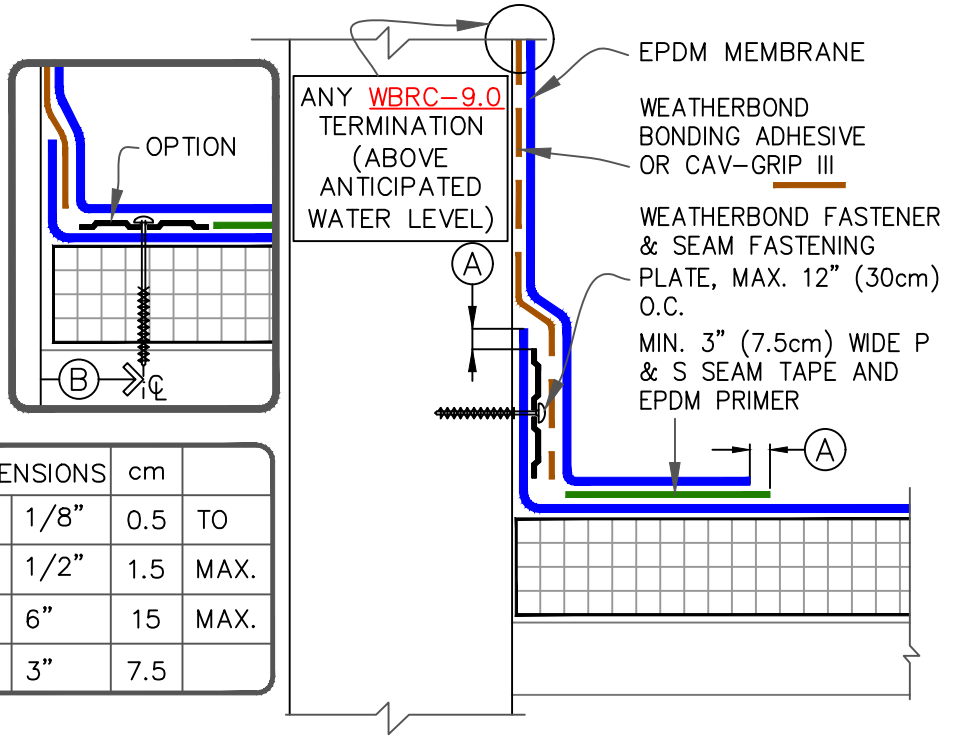

DIMENSIONS	cm
(A) 1/8"	0.5 TO
1/2"	1.5 MAX.
(B) 6"	15 MAX.
(C) 3"	7.5

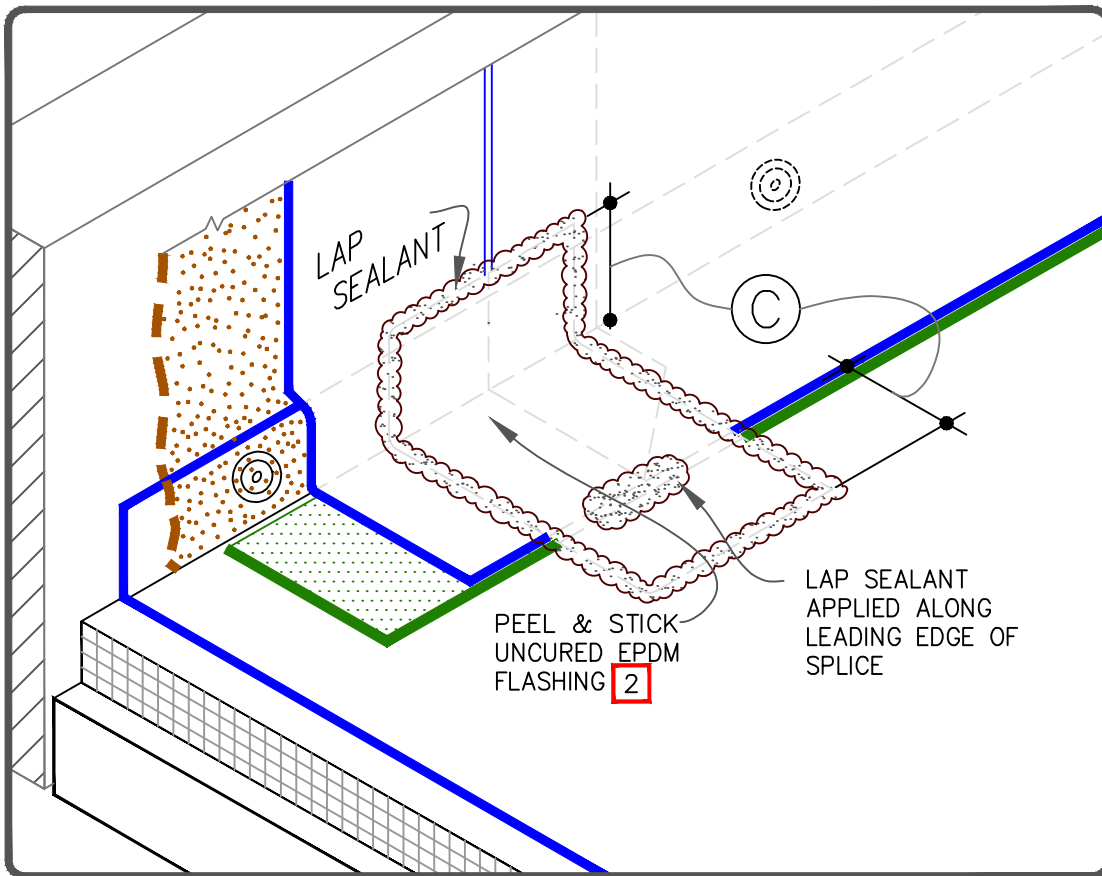

P&S (PEEL & STICK)



PARAPET / CURB WITH SEPARATE MEMBRANE FLASHING

- ● EPDM MEMBRANE
- APPROVED SUBSTRATE
- 0 ● SEE NOTE

EPDM ROOFING SYSTEM

WBRC-12.2

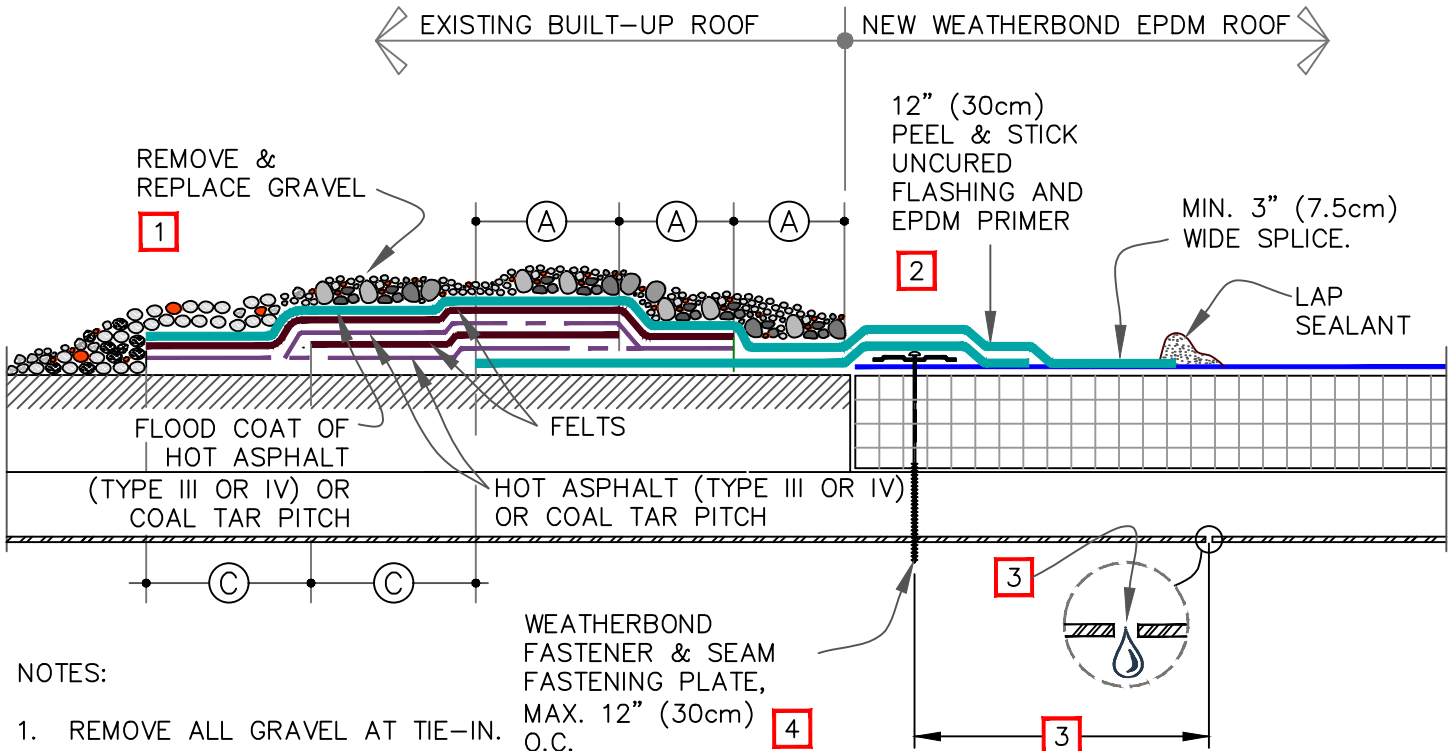

NOTES:

1. REMOVE ALL GRAVEL AT TIE-IN.
2. SPLICE TWO PIECES OF UNCURED EPDM OR PEEL & STICK UNCURED EPDM TOGETHER TO ACHIEVE DESIRED WIDTH.
3. IF FLUTES ARE PERPENDICULAR TO THE TIE-IN DRILL A 3/8" (1cm) DIAMETER WEEP HOLE ON THE BOTTOM FLUTES OF THE STEEL DECK ALONG THE PERIMETER TO THE TIE-IN 6" (15cm) FROM THE SEAM FASTENING PLATE.
4. ON MECHANICALLY FASTENED SYSTEMS, HPWX FASTENERS AND POLYMER SEAM PLATES ARE REQUIRED OVER STEEL DECKS.
5. IF WATER PONDS OR FLOWS OVER TIE-IN FROM BUR SURFACE, USE [DETAIL WBRC-13.2](#).
6. ON BALLASTED SYSTEMS, USE CONCRETE PAVERS TO PREVENT BALLAST MIGRATION.

DIMENSIONS		cm	
(A)	5"	13	MIN.
(B)	2"	5	± 1/2" (1.5cm)
(C)	6"	15	

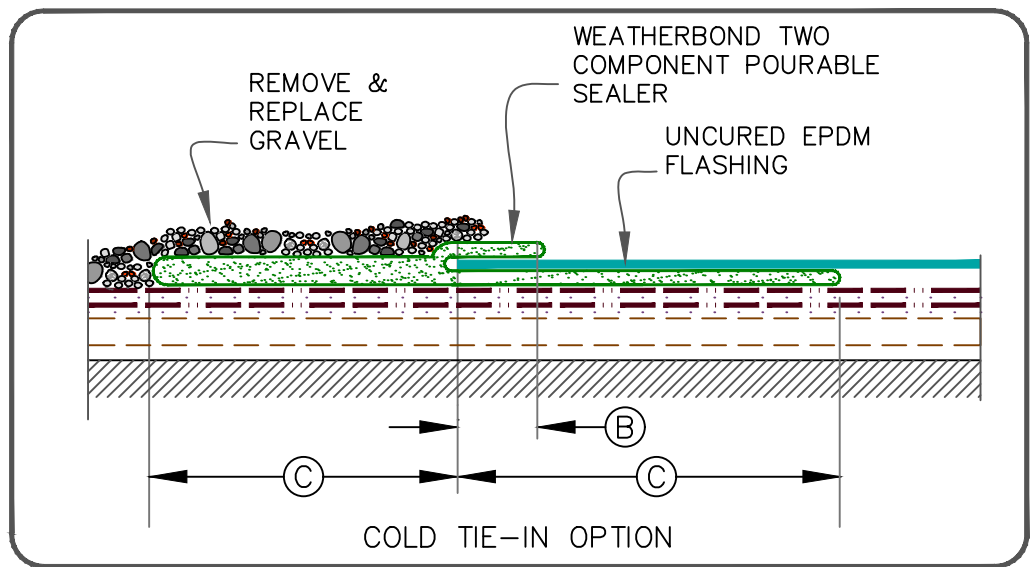

BUILT-UP ROOFING TIE-IN OVER STEEL ROOF DECK

- EPDM MEMBRANE
- APPROVED SUBSTRATE
- SEE NOTE

EPDM ROOFING SYSTEM

WBRC-13.1

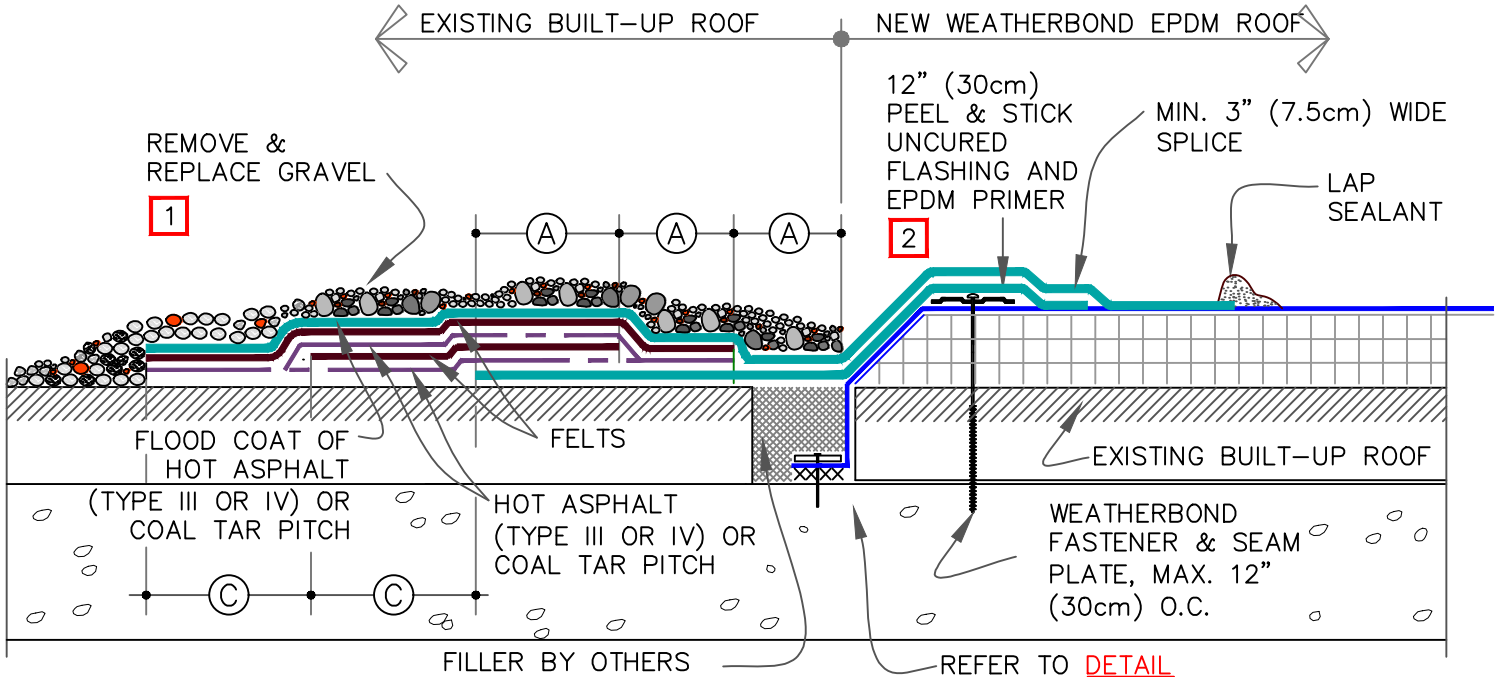

NOTES:

1. REMOVE ALL GRAVEL AT TIE-IN.
2. SPLICE TWO PIECES OF UNCURED OR PEEL & STICK UNCURED TOGETHER TO ACHIEVE DESIRED WIDTH.
3. WATER CUT-OFF MUST BE UNDER CONSTANT COMPRESSION.
4. WEATHERBOND IS NOT RESPONSIBLE FOR DAMAGE TO THE BUILT-UP ROOF OR STRUCTURAL DECK RESULTING FROM PONDED WATER; THIS DETAIL APPLIES TO RE-ROOFING WHEN A TEAR-OFF IS NOT SPECIFIED AND WAS DESIGNED TO PREVENT MIGRATION OF WATER INTO THE NEW ROOFING SYSTEM.
5. ON BALLASTED SYSTEMS, USE CONCRETE PAVERS TO PREVENT BALLAST MIGRATION.

DIMENSIONS	cm	
(A)	5"	13 MIN.
(B)	2"	± 1/2" (1.5cm)
(C)	6"	15

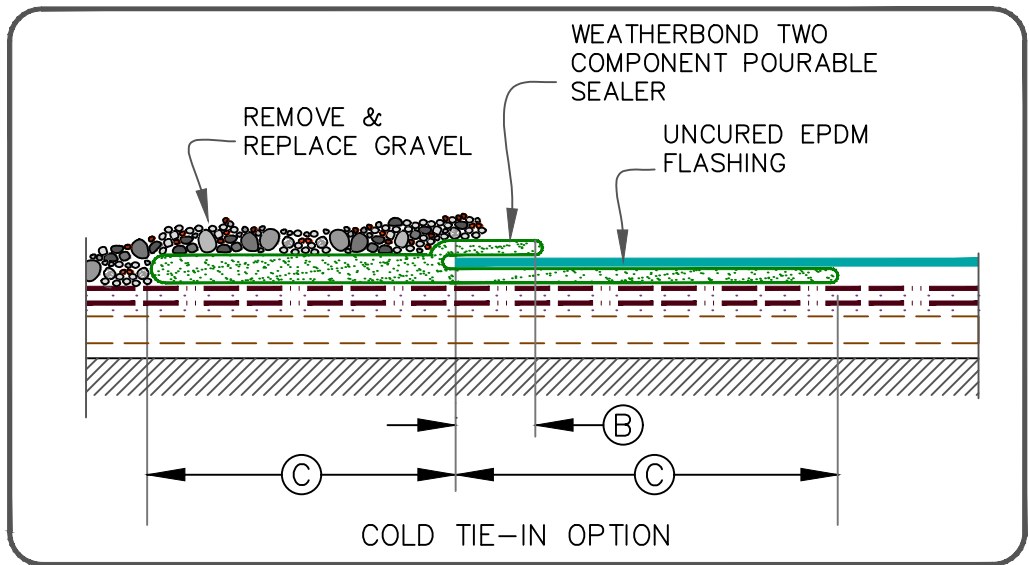

BUILT-UP ROOFING TIE-IN OVER CONCRETE ROOF DECK

- EPDM MEMBRANE
- APPROVED SUBSTRATE
- SEE NOTE

EPDM ROOFING SYSTEM

WBRC-13.2

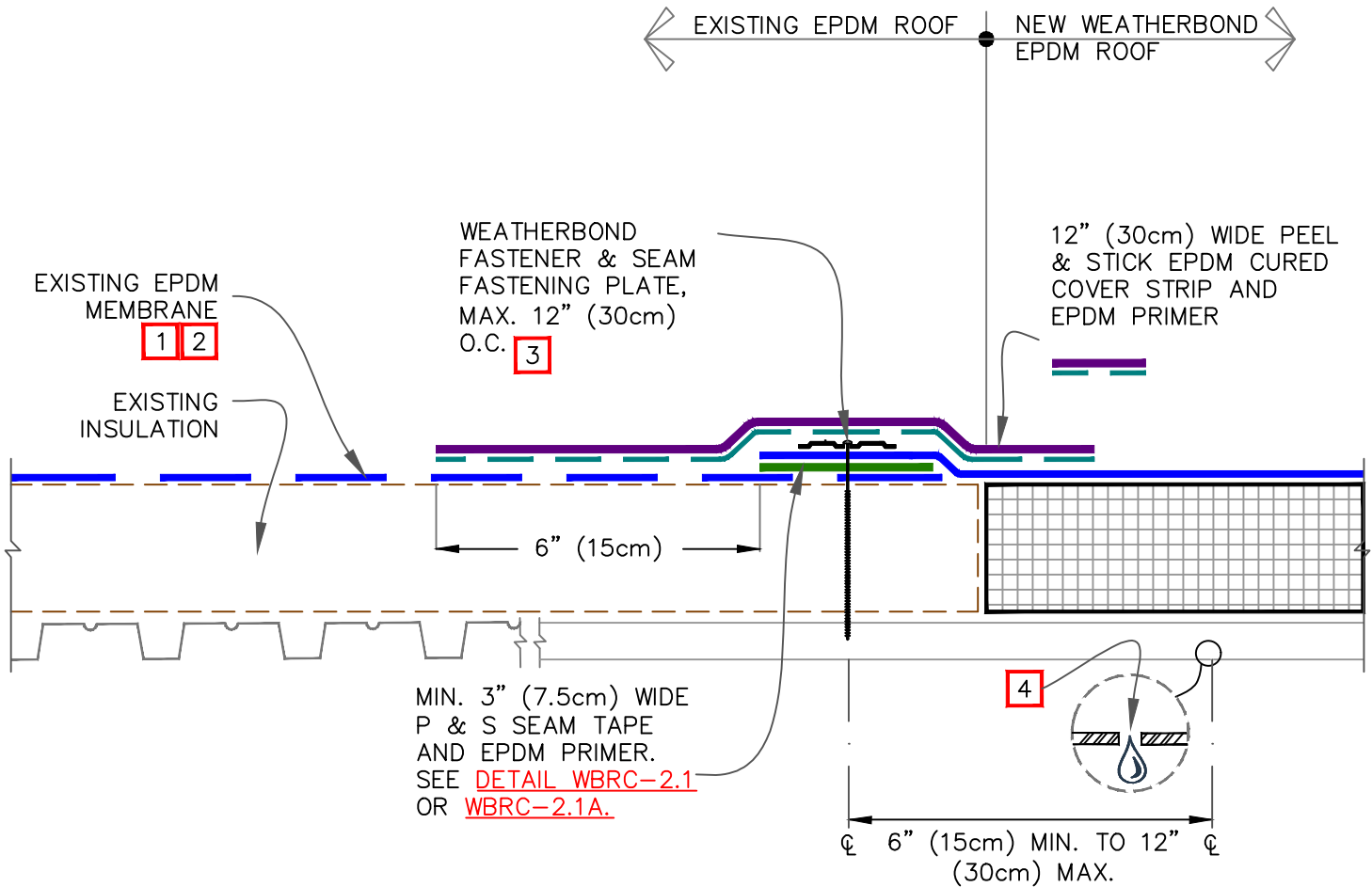



NOTES:

1. CONTACT MANUFACTURER OF EXISTING EPDM MEMBRANE ROOFING SYSTEM TO VERIFY ACCEPTANCE OF TIE-IN AND TO NOT VOID EXISTING WARRANTY.
2. PRIOR TO SPLICING, CLEAN EXISTING EPDM MEMBRANE BY SCRUBBING THE SPLICE AREA WITH WEATHERED MEMBRANE CLEANER AND ALLOW TO DRY.
3. ON MECHANICALLY FASTENED SYSTEMS, HPWX FASTENERS AND POLYMER SEAM PLATES ARE REQUIRED OVER STEEL DECKS.
4. IF FLUTES ARE PERPENDICULAR TO THE TIE-IN DRILL A 3/8" (1cm) DIAMETER WEEP HOLE INTO THE BOTTOM FLUTES OF THE STEEL DECK ALONG THE PERIMETER OF THE TIE-IN 6" (15cm) MINIMUM TO 12" (30cm) MAXIMUM FROM THE SEAM FASTENING PLATE.



TIE-IN TO EXISTING EPDM MEMBRANE

-  EPDM MEMBRANE
-  APPROVED SUBSTRATE
-  SEE NOTE

EPDM ROOFING SYSTEM

WBRC-13.3

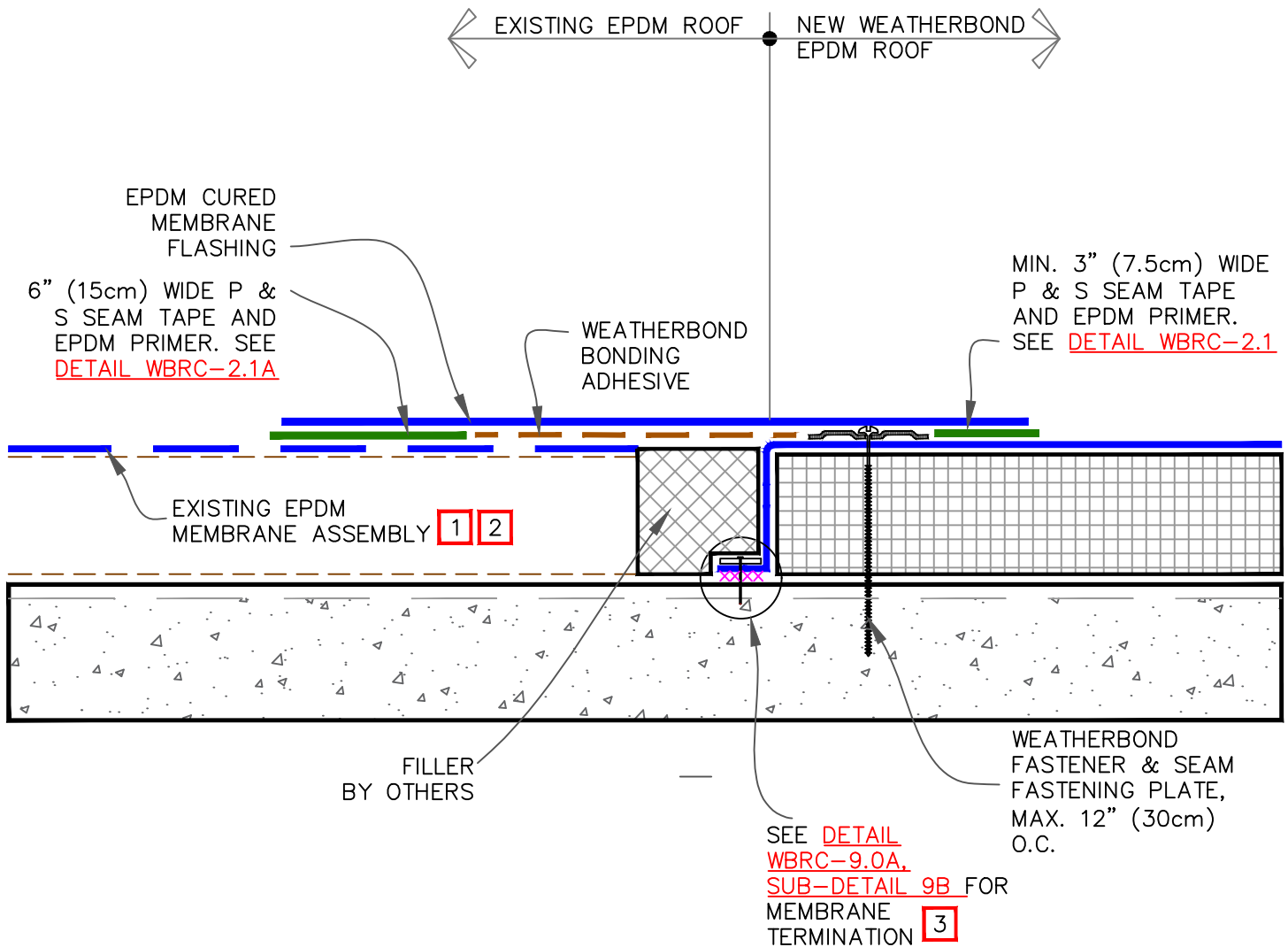

NOTES:

1. CONTACT MANUFACTURER OF EXISTING EPDM MEMBRANE ROOFING SYSTEM TO VERIFY ACCEPTANCE OF TIE-IN AND TO NOT VOID EXISTING WARRANTY.
2. PRIOR TO SPLICING, CLEAN EXISTING EPDM MEMBRANE BY SCRUBBING THE SPLICE AREA WITH WEATHERED MEMBRANE CLEANER; ALLOW TO DRY.
3. WATER CUT-OFF MASTIC MUST BE HELD UNDER CONSTANT COMPRESSION. WHEN RE-ROOFING OVER PRE-CAST CONCRETE, APPLY LIBERAL BEAD OF WATER CUT-OFF MASTIC IN THE JOINTS TO PREVENT MOISTURE MIGRATION.

MAXIMUM WARRANTY: 30 YEARS



EPDM TIE-IN OVER CONCRETE DECK

- EPDM MEMBRANE
- APPROVED SUBSTRATE
- SEE NOTE

EPDM ROOFING SYSTEM

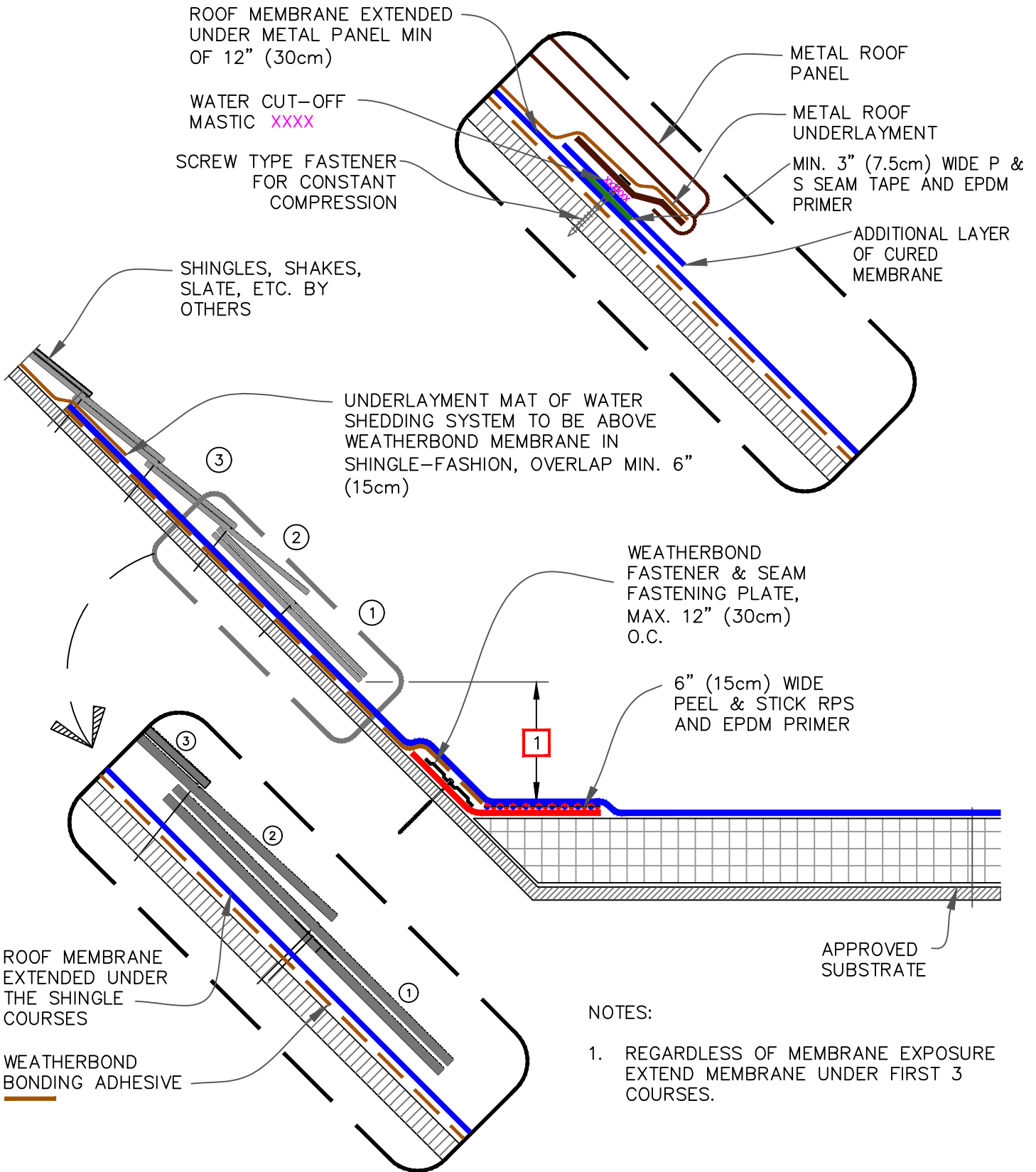

WBRC-13.4



MAXIMUM WARRANTY: 30 YEARS



TIE-IN SHINGLED OR METAL PANEL ROOF

-  EPDM MEMBRANE
-  APPROVED SUBSTRATE
-  SEE NOTE

EPDM ROOFING SYSTEM

WBRC-13.5

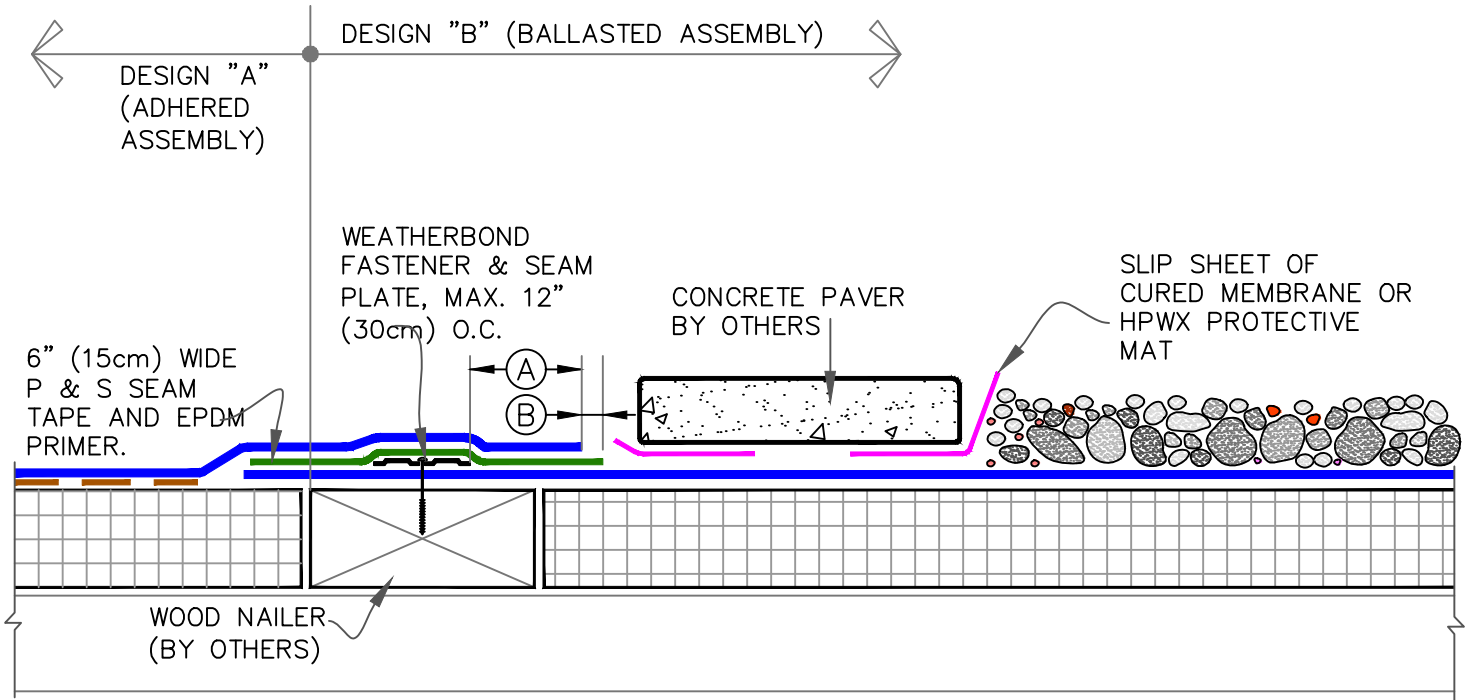

(A) BALLASTED TO ADHERED TIE-IN

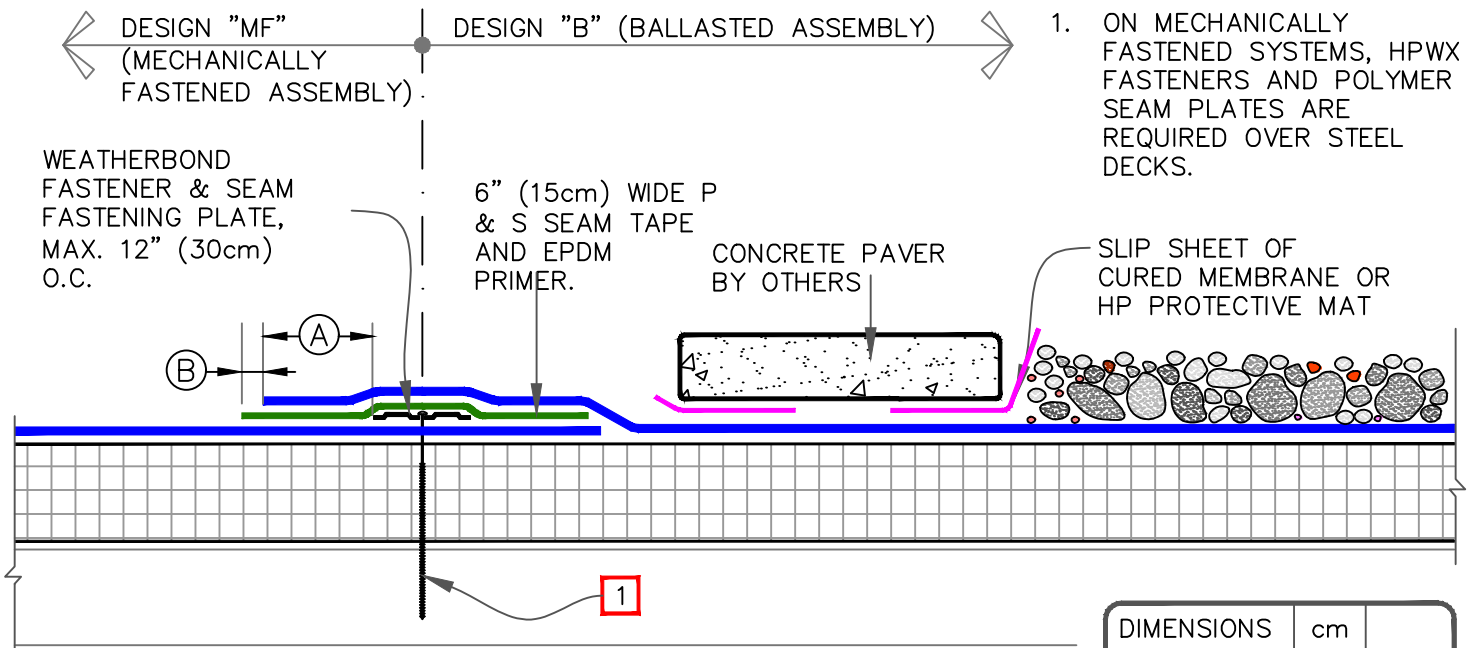

NOTE:

1. ON MECHANICALLY FASTENED SYSTEMS, HPWX FASTENERS AND POLYMER SEAM PLATES ARE REQUIRED OVER STEEL DECKS.

(B) BALLASTED TO MECHANICALLY FASTENED TIE-IN

DIMENSIONS	cm	
(A) 2"	5	MIN.
(B) 1/8"	0.5	MIN.
1/2"	1.5	MAX.



TIE-IN BALLASTED ROOF TO ADHERED AND MECHANICALLY FASTENED

- ● EPDM MEMBRANE
- APPROVED SUBSTRATE
- 0 ● SEE NOTE

EPDM ROOFING SYSTEM

WBRC-13.6

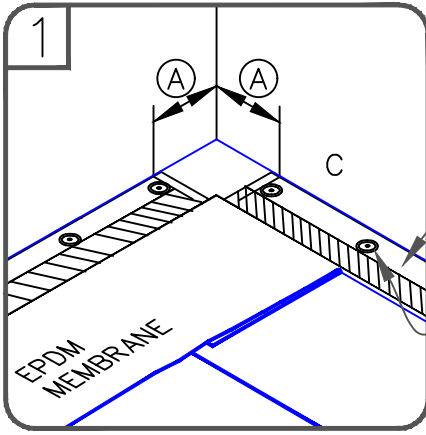

6" (15cm) WIDE PEEL & STICK RPS (MAY BE FASTENED INTO VERTICAL SUBSTRATE)

WEATHERBOND SEAM PLATE & FASTENER.

EPDM PRIMER

CUT 45° AND APPLY EPDM PRIMER AND P & S SEAM TAPE

DIMENSIONS	cm	
(A) 6"	15	TO
9"	23	

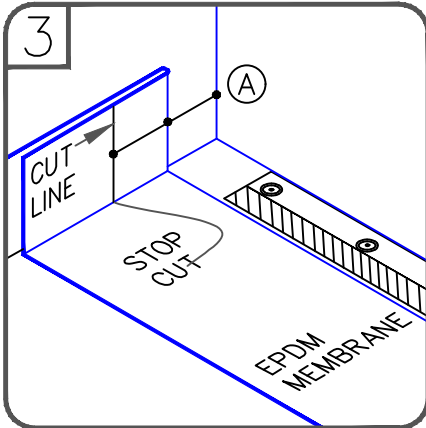
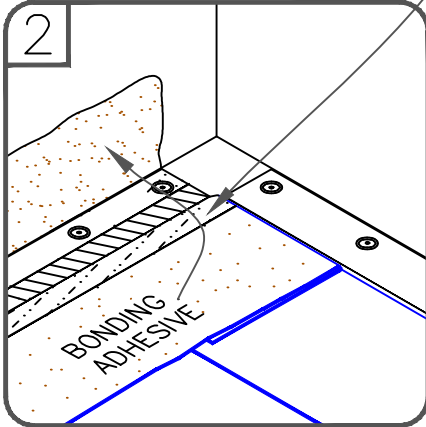
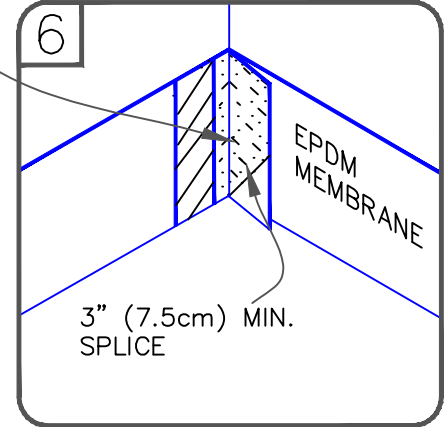
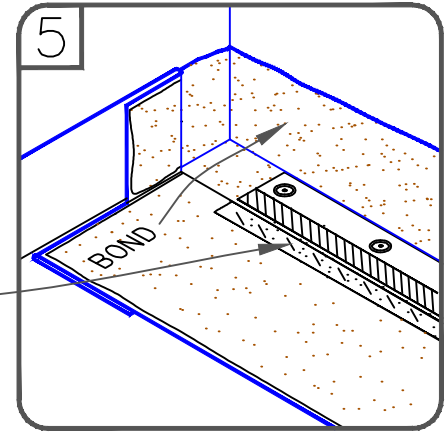

NOTES:

- REFER TO DETAIL [WBRC-15.3](#) OR [WBRC-15.4A](#) FOR INSIDE CORNER INSTALLATION REQUIREMENTS.

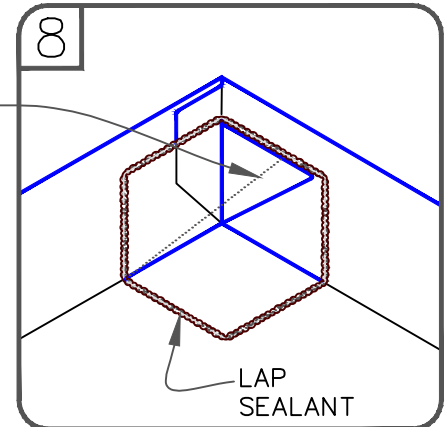
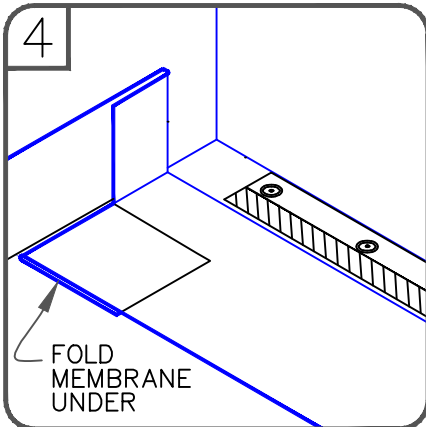
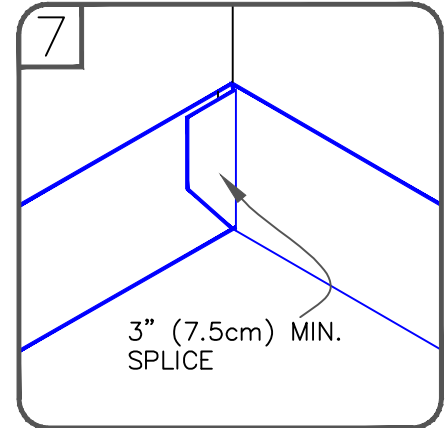

PIG EAR ON OPPOSITE WALL

LAP SEALANT



INSIDE CORNER WALL FLASHING WITH RPS (OPTION 1)

- EPDM MEMBRANE
- APPROVED SUBSTRATE
- SEE NOTE

EPDM ROOFING SYSTEM

WPRC-15.1

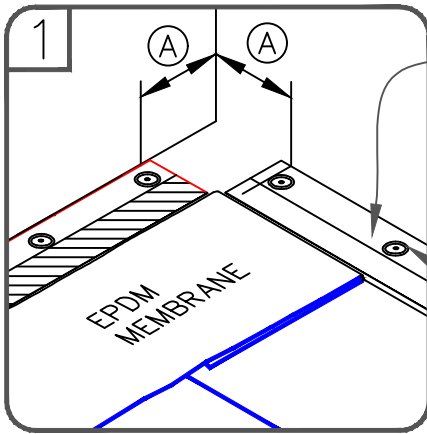

6" (15cm) PEEL & STICK RPS
(MAY BE FASTENED INTO
VERTICAL SUBSTRATE)

FORM PIG EAR WITH
CONTINUOUS MEMBRANE AT
CORNER AS SHOWN

WEATHERBOND SEAM PLATE
& FASTENER.

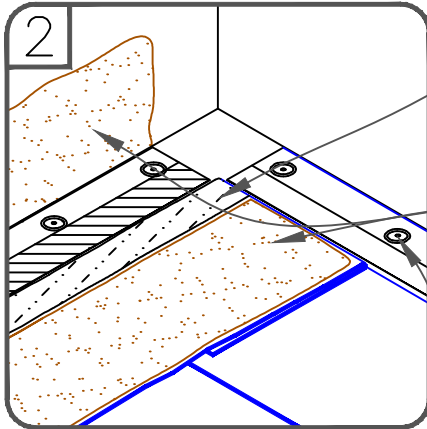

EPDM PRIMER

CUT & REMOVE EXCESSIVE
MEMBRANE

WEATHERBOND BONDING
ADHESIVE

WEATHERBOND SEAM
FASTENING PLATE &
FASTENER.

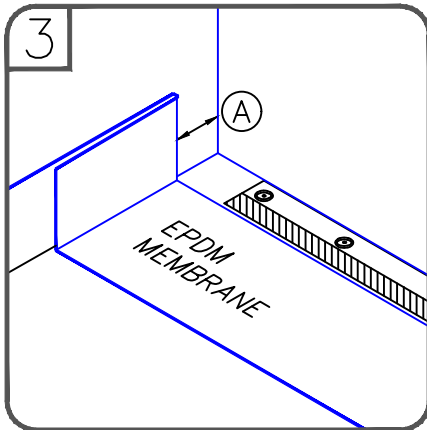

DIMENSIONS		cm	
(A)	6"	15	TO
	9"	23	

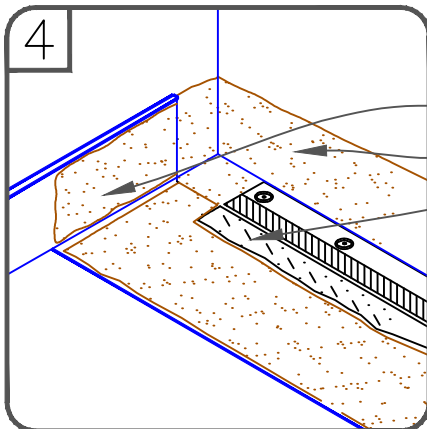

WEATHERBOND BONDING
ADHESIVE

EPDM PRIMER

6" (15cm) WIDE PEEL &
STICK UNCURED EPDM
FLASHING AND EPDM PRIMER

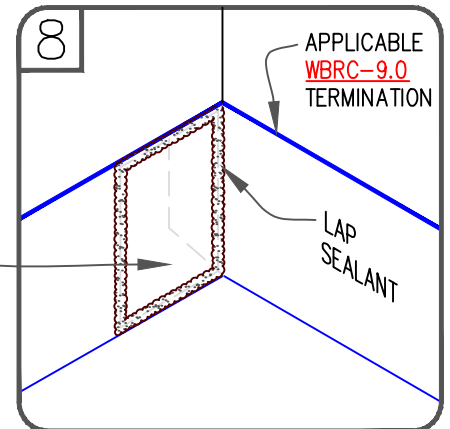
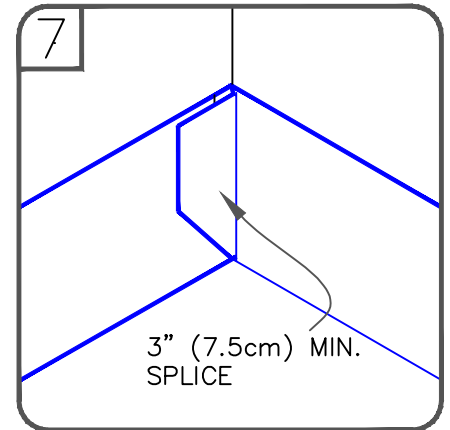
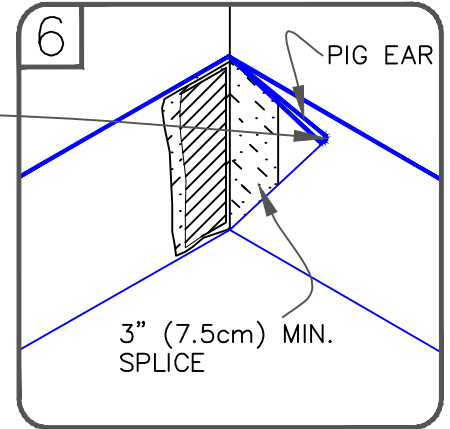
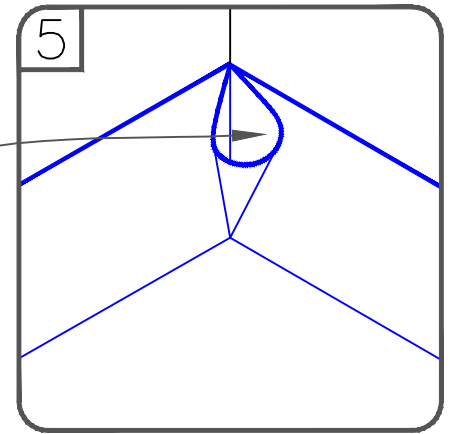

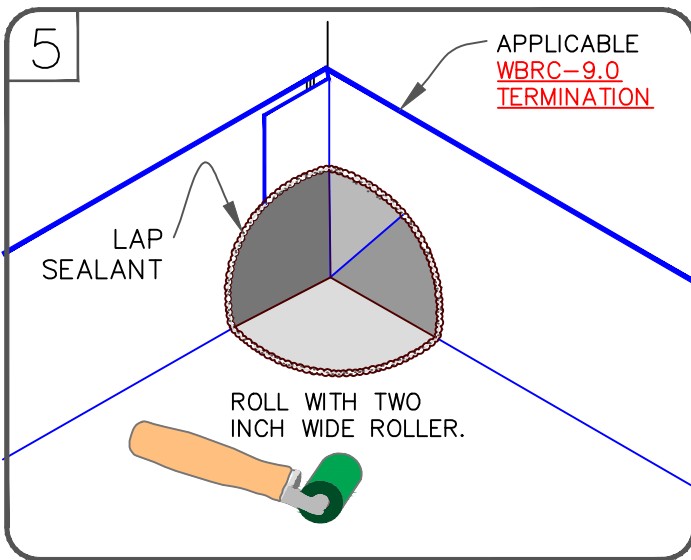
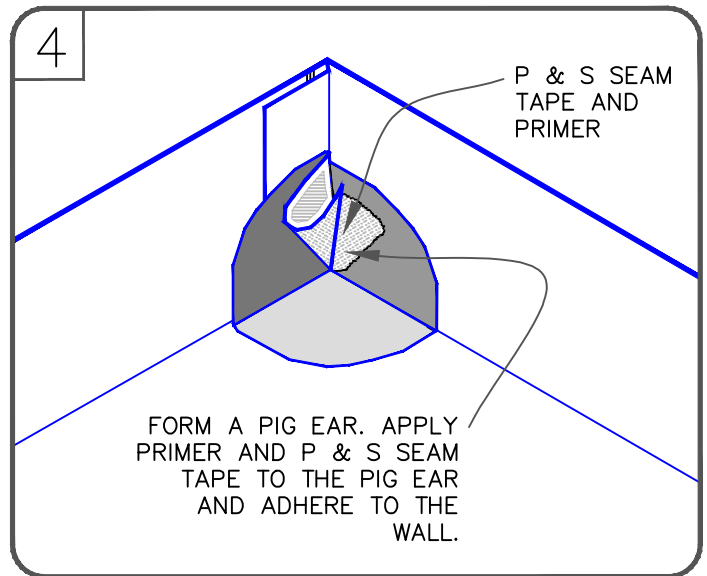
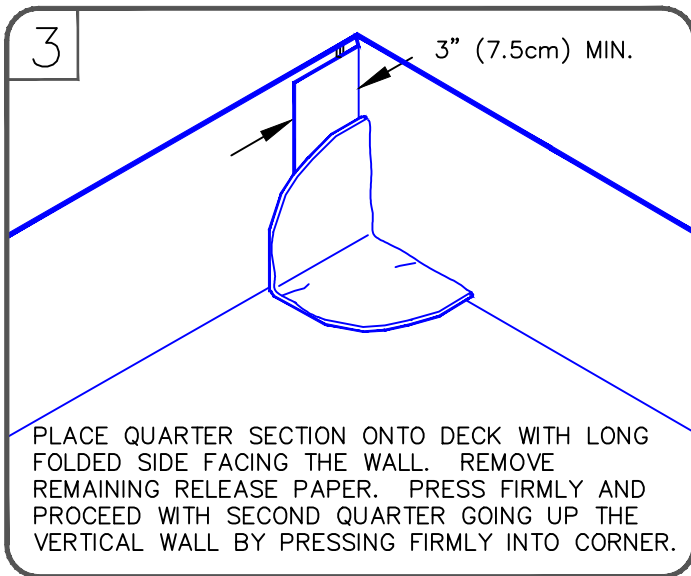
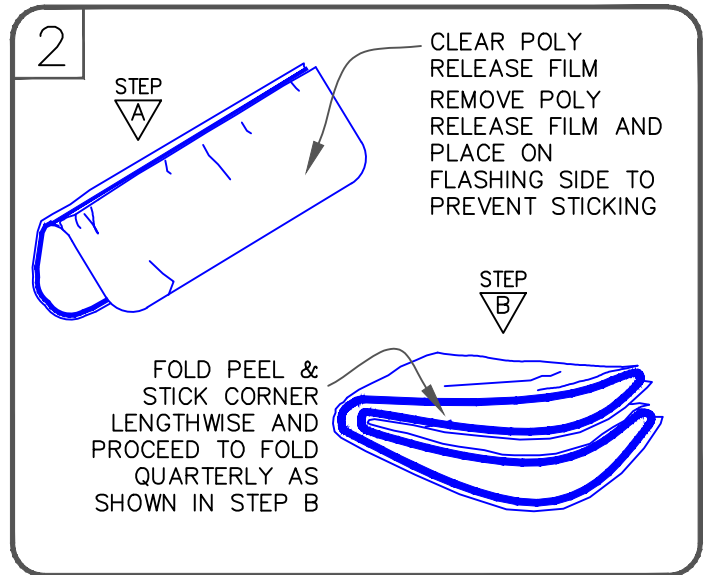
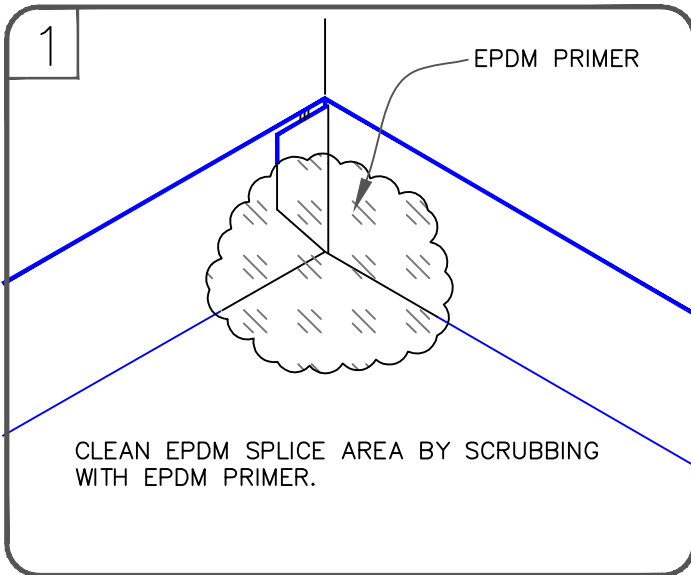

NOTES:

1. PRE-CUT 7" X 9" CORNER OR 9" X 9" PEEL & STICK UNCURED EPDM.
2. FOR PROJECTS WITH 25 AND 30-YEAR WARRANTIES OR WHEN USING 90-MIL MEMBRANE, INSTALL A 6" T-JOINT COVER PRIOR TO INSTALLING A 12" T-JOINT COVER. SEAL TOP LAYER WITH CONTINUOUS LAP SEALANT. PER DETAIL WBRC-15.4 A.
3. A HEAT GUN MUST BE USED WHEN FORMING PEEL & STICK UNCURED FLASHING IN COLDER TEMPERATURES.

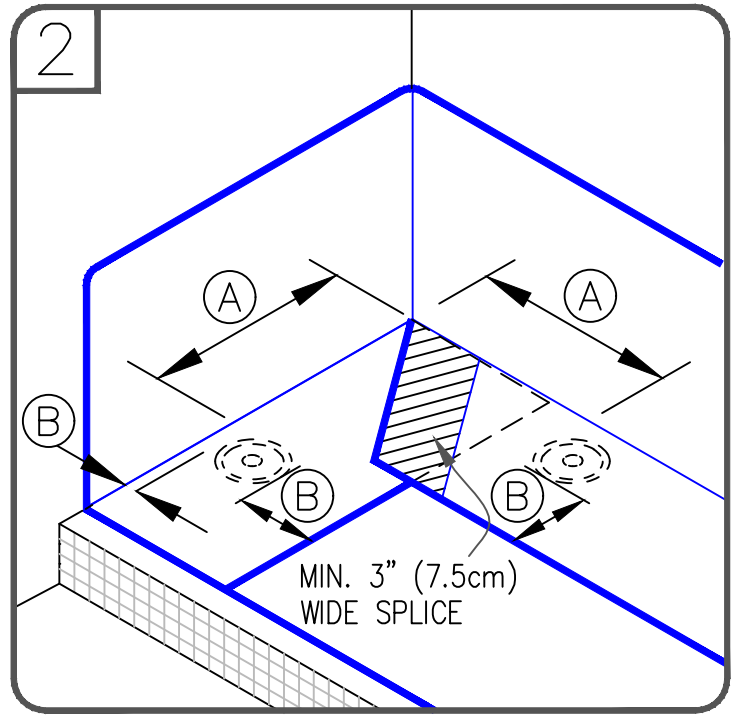
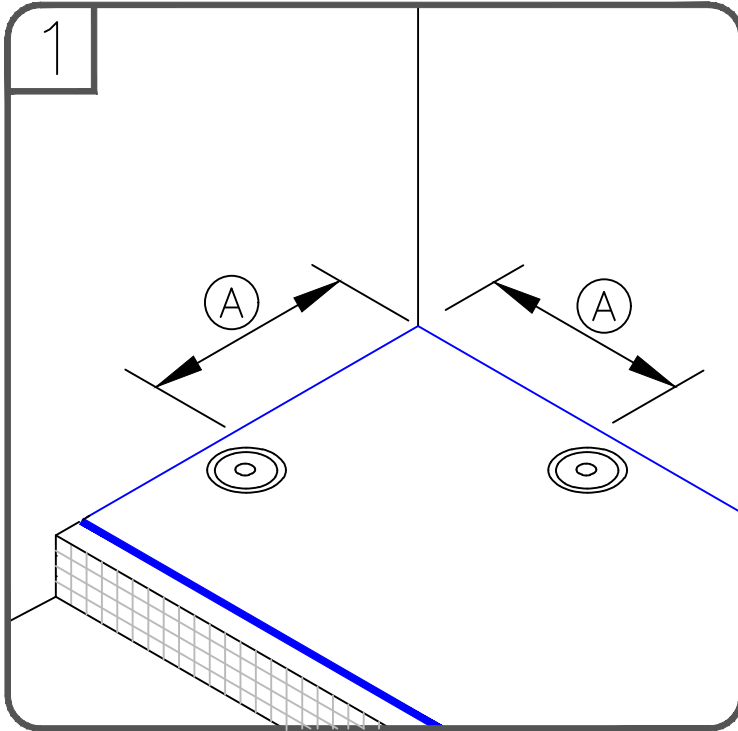

DIMENSIONS	cm	
(A)	6"	15 TO
	9"	23
(B)	3"	7.5

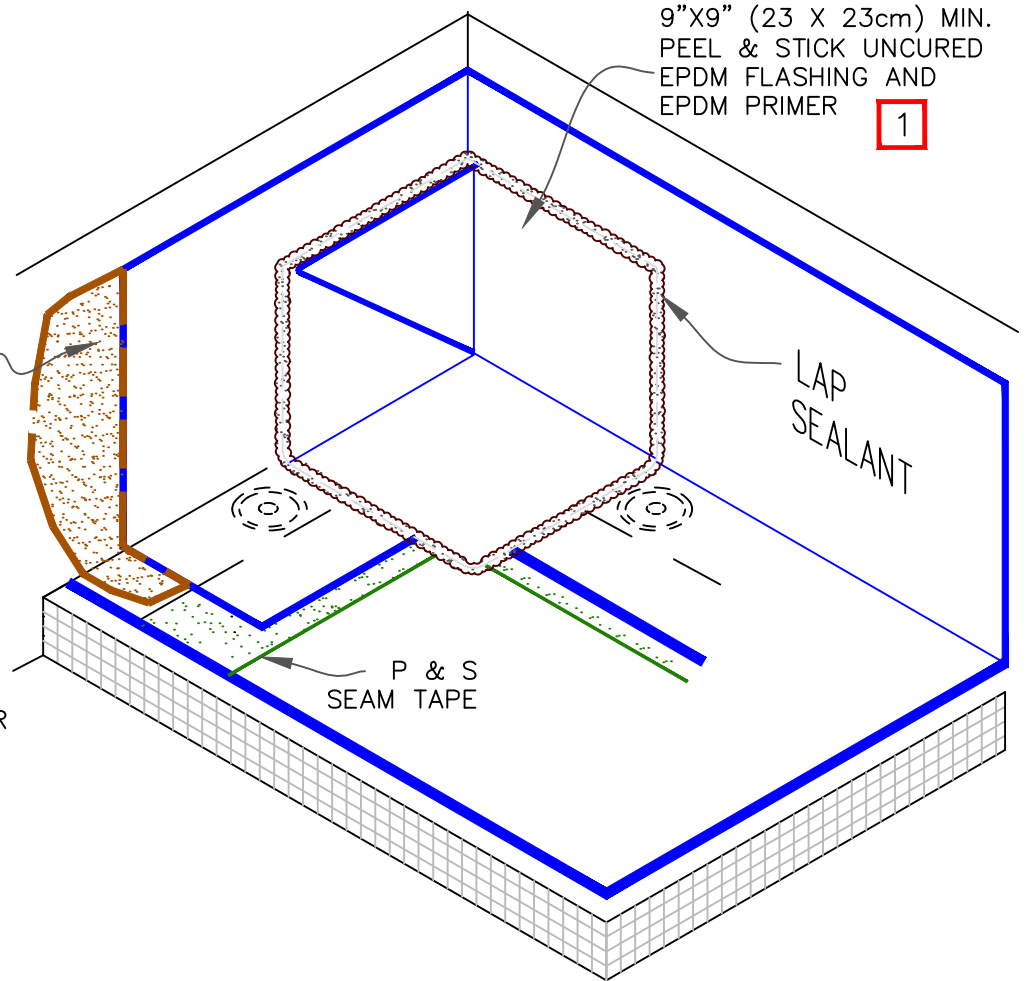

NOTES:

1. A HEAT GUN MUST BE USED WHEN FORMING PEEL & STICK UNCURED FLASHING IN COLDER TEMPERATURES.
2. FOR PROJECTS USING 90-MIL MEMBRANE, REFER TO [DETAIL WBRC-15.4A](#) FOR RECOMMENDED FLASHING ENHANCEMENTS.



INSIDE CORNER WITH SEPARATE EPDM WALL FLASHING

- EPDM MEMBRANE
- APPROVED SUBSTRATE
- SEE NOTE

EPDM ROOFING SYSTEM

WBRC-15.4A

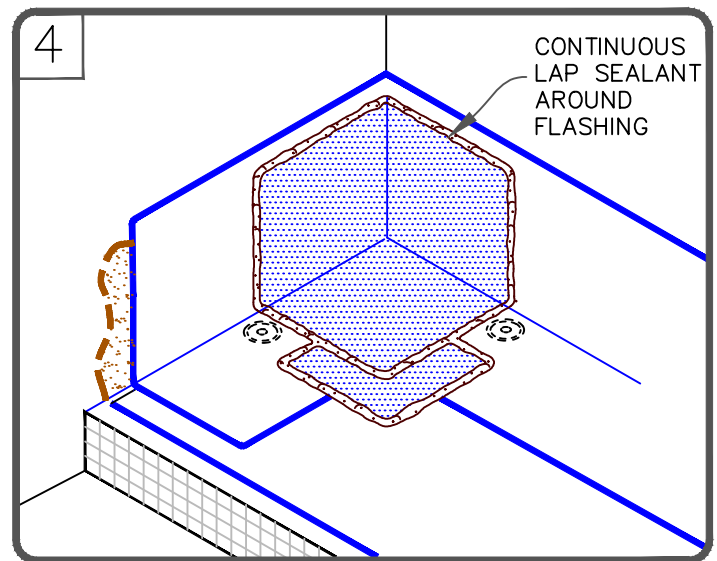
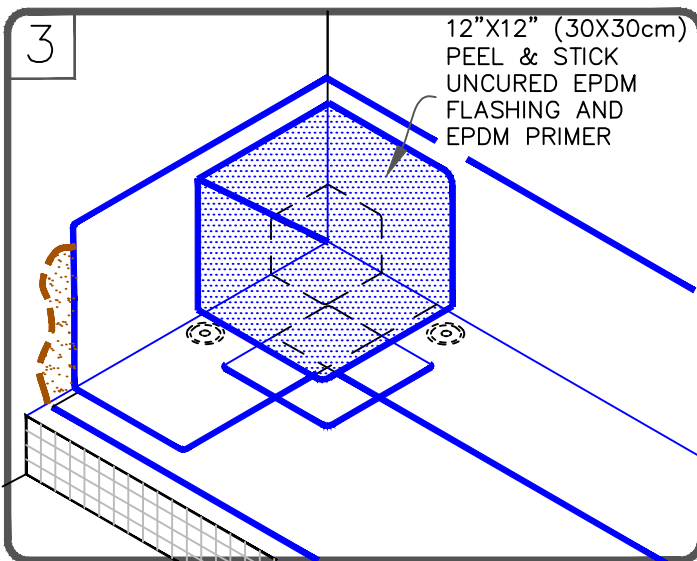
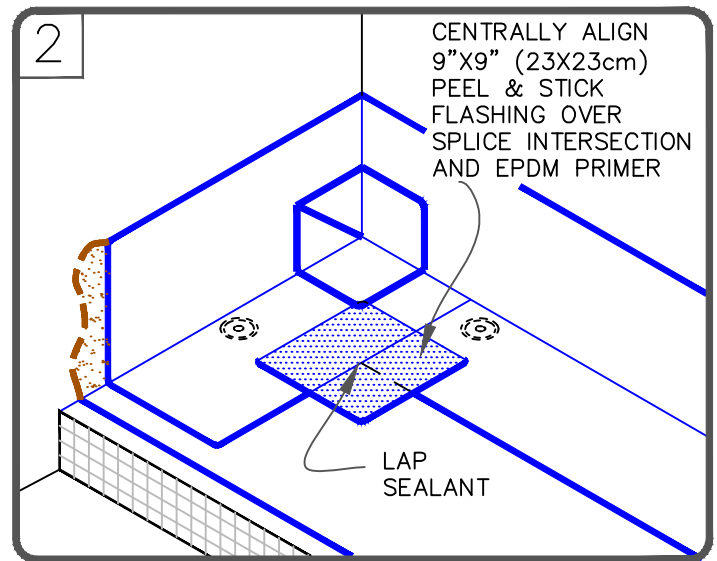
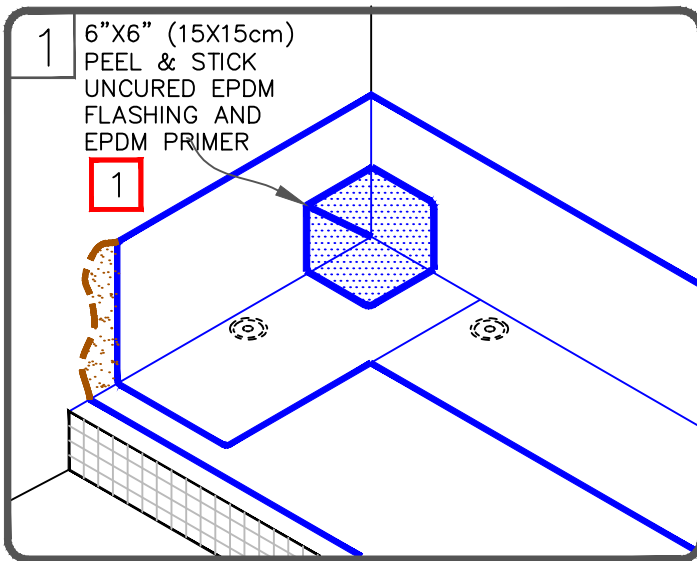



NOTES:

1. A 7"X9" (17.5cm X 23cm) PEEL & STICK PRE-CUT INSIDE/OUTSIDE CORNER MAY BE CUT DOWN TO 6" X 6" (7.5cm X 7.5cm).
2. A HEAT GUN MUST BE USED WHEN FORMING PEEL & STICK UNCURED EPDM FLASHING IN COLDER TEMPERATURES.
3. APPLY PRIMER AND PEEL & STICK SEAM TAPE TO ADHERE PIG EAR TO THE WALL.



INSIDE CORNER FLASHING FOR PROJECTS WITH 90-MIL MEMBRANE

-  EPDM MEMBRANE
-  APPROVED SUBSTRATE
-  SEE NOTE

EPDM ROOFING SYSTEM

WBRC-15.4B

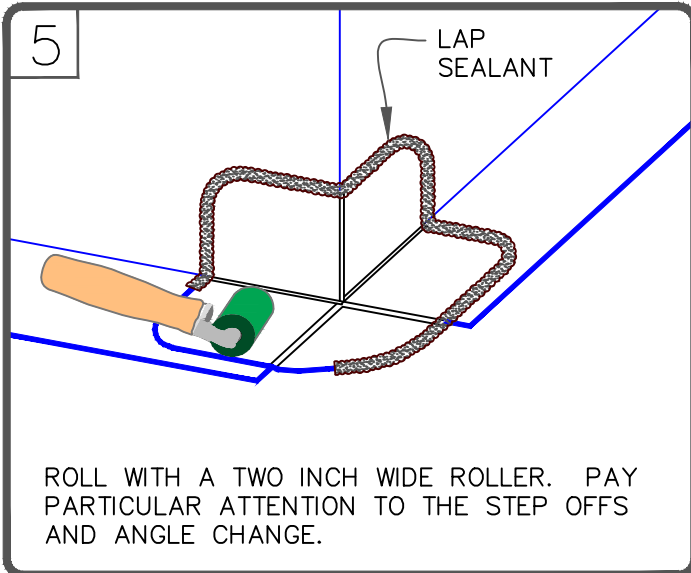
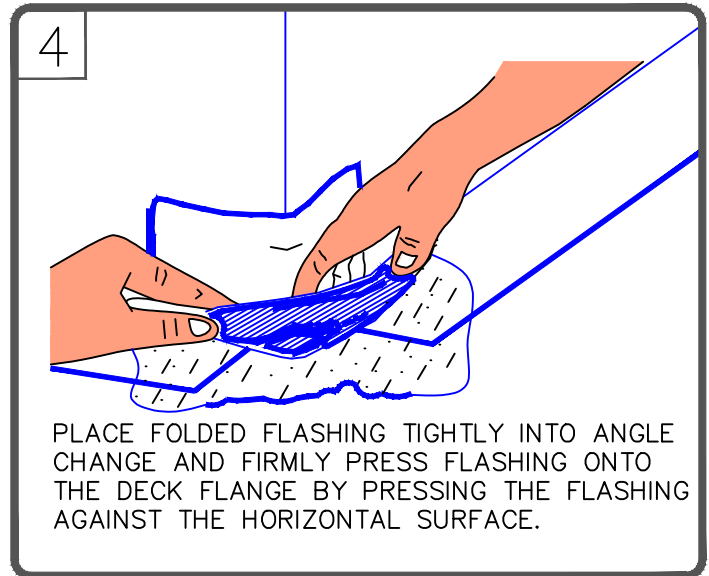
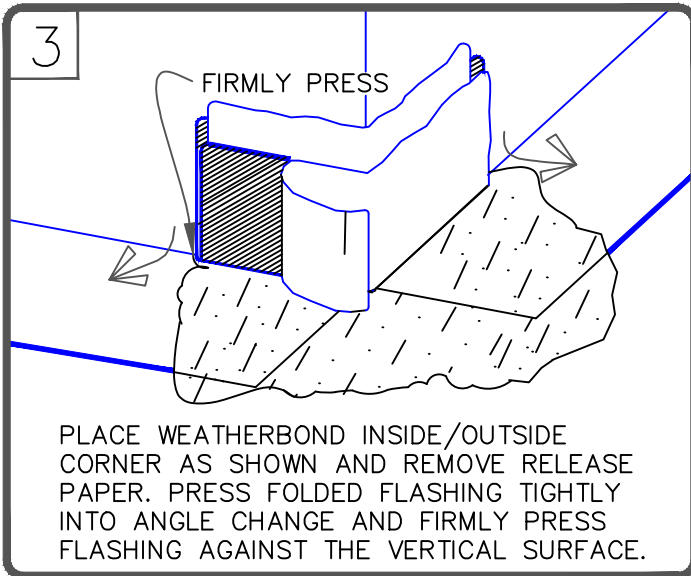
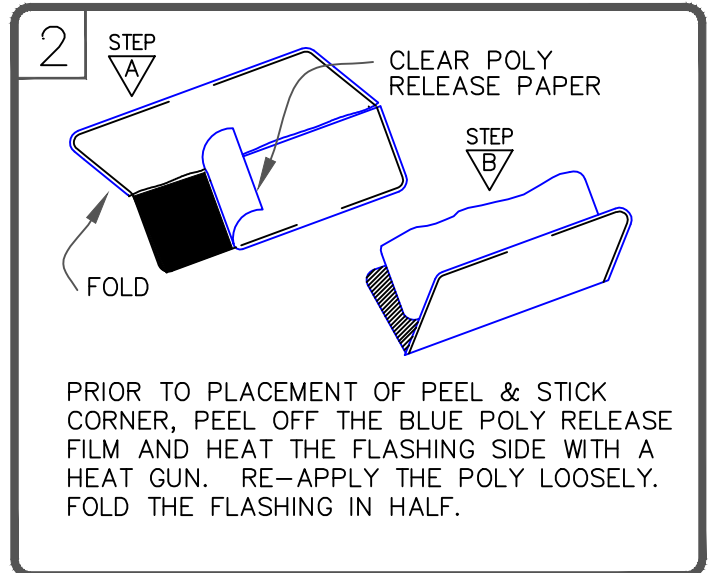
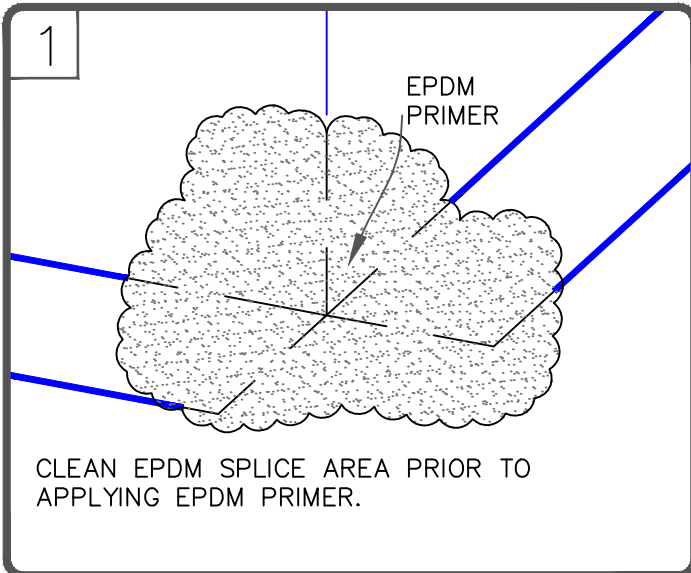



NOTE:

1. FOR PROJECTS USING 90-MIL MEMBRANE, SEE [DETAIL WBRC-15.7A](#) FOR RECOMMENDED FLASHING ENHANCEMENTS.



OUTSIDE CORNER WITH PRE-CUT PEEL & STICK FLASHING

-  EPDM MEMBRANE
-  APPROVED SUBSTRATE
-  SEE NOTE

EPDM ROOFING SYSTEM

WBRC-15.5

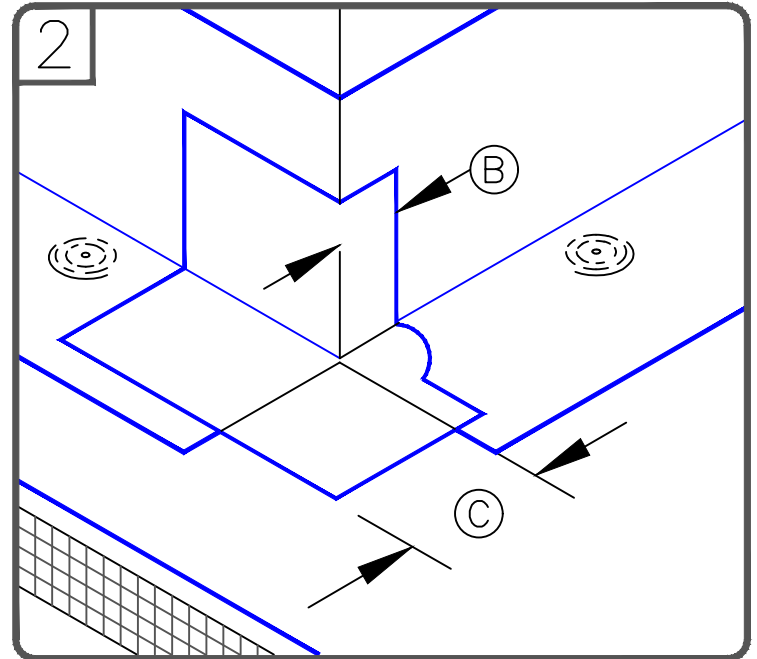
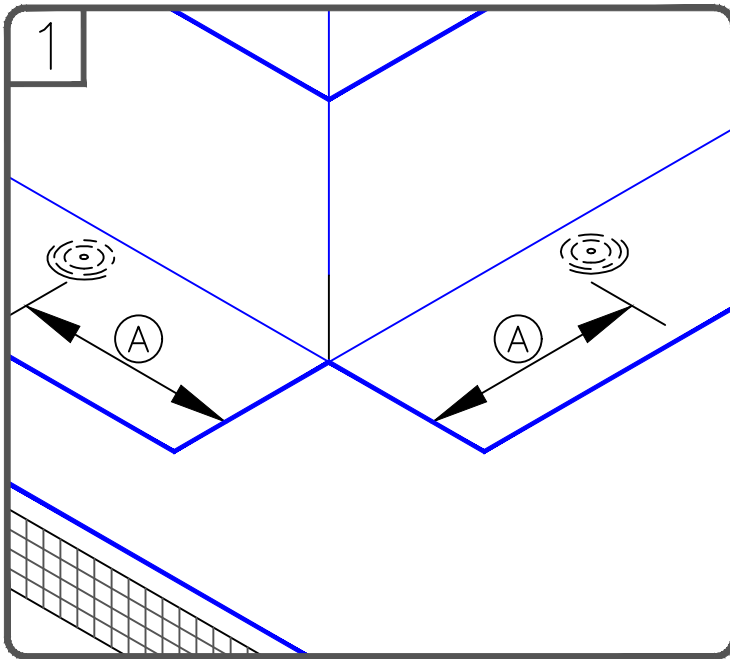

DIMENSIONS		cm	
(A)	6"	15	TO
	9"	23	
(B)	2"	5	MIN.
(C)	3"	7.5	MAX.

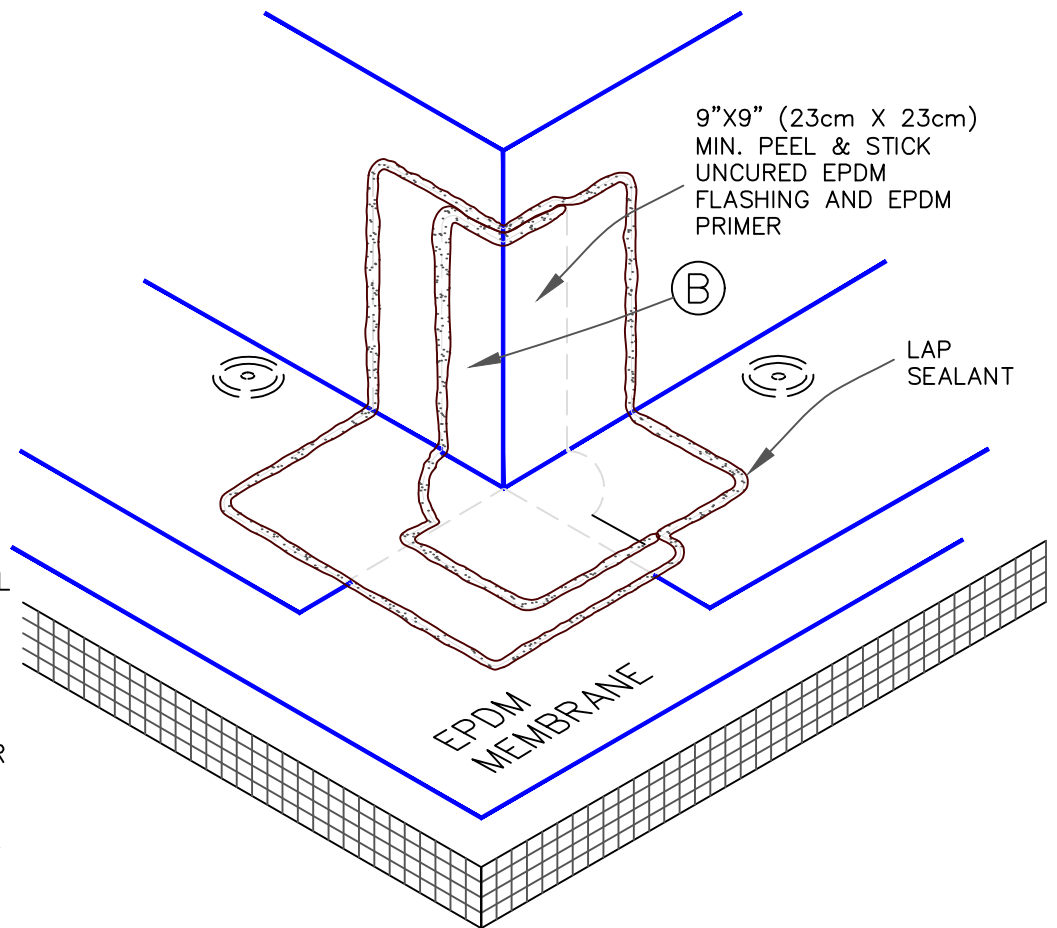

NOTES:

1. A HEAT GUN MUST BE USED WHEN FORMING PEEL & STICK UNCURED FLASHING IN COLDER TEMPERATURES.
2. FOR PROJECTS USING 90-MIL MEMBRANE, REFER TO [DETAIL WBRC-15.7A](#) FOR RECOMMENDED FLASHING ENHANCEMENTS.



OUTSIDE CORNER WITH PEEL & STICK UNCURED EPDM FLASHING (2 PIECE)

- EPDM MEMBRANE
- APPROVED SUBSTRATE
- SEE NOTE

EPDM ROOFING SYSTEM
WBRC-15.6

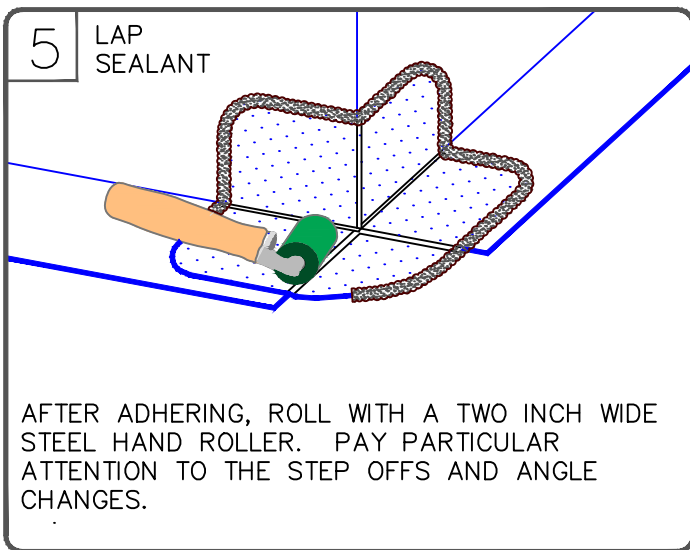
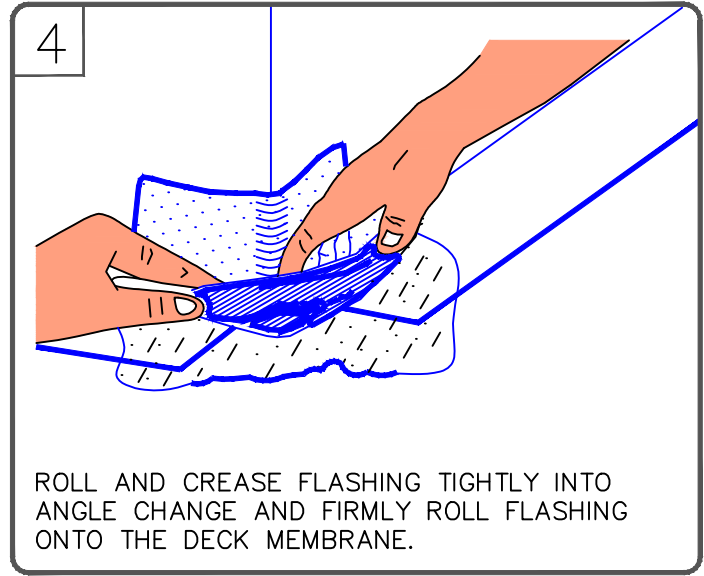
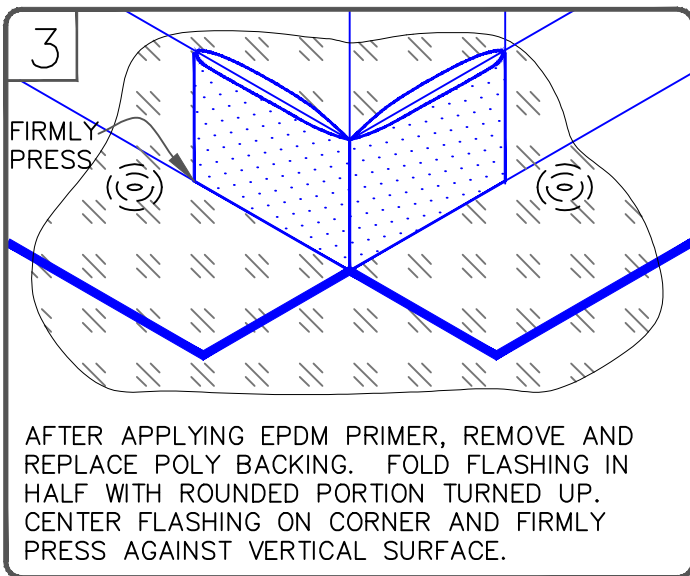
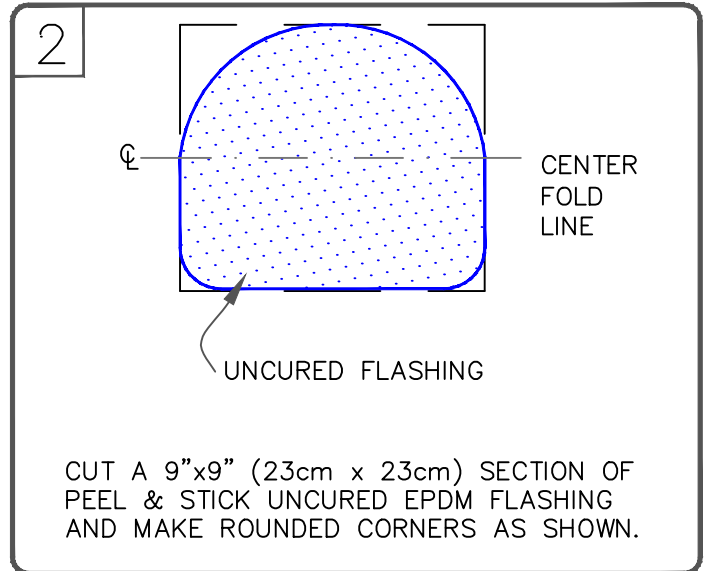
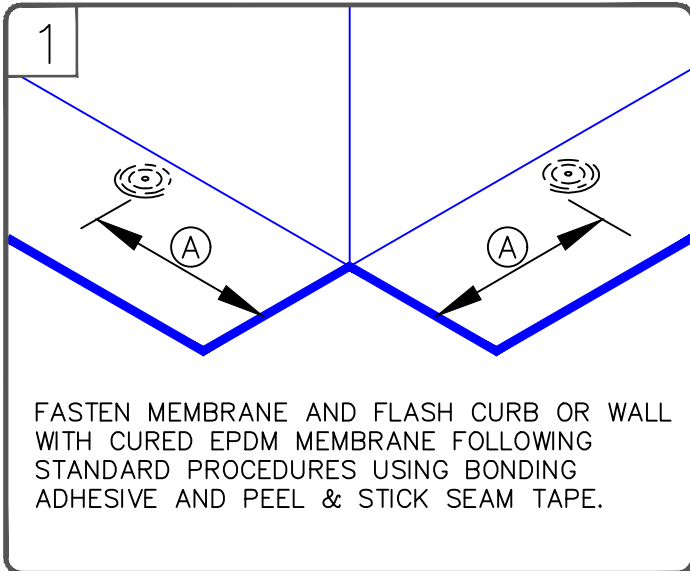

DIMENSIONS		cm	
(A)	6"	15	TO
	9"	23	

NOTES:

- FOR PROJECTS WITH 25 & 30-YEAR WARRANTIES OR WHEN USING 90-MIL MEMBRANE, REFER TO [DETAIL WBRC-15.7A](#) FOR REQUIRED FLASHING ENHANCEMENTS.
- A HEAT GUN MUST BE USED WHEN FORMING PEEL & STICK UNCURED EPDM FLASHING IN COLDER TEMPERATURES.



OUTSIDE CORNER WITH PEEL & STICK UNCURED EPDM FLASHING (1 PIECE)

- EPDM MEMBRANE
- APPROVED SUBSTRATE
- SEE NOTE

EPDM ROOFING SYSTEM

WBRC-15.7

1

FASTEN MEMBRANE AND FLASH CURB OR WALL WITH CURED EPDM MEMBRANE FOLLOWING STANDARD PROCEDURES.

2

USE PRE-CUT T-JOINT COVERS OR CUT A 6"x6" (15X15cm) & 12"x12" (30X30cm) SECTION OF PEEL & STICK UNCURED FLASHING AND ROUND CORNERS

3

CLEAN EPDM SPLICE AREA WITH WEATHERED MEMBRANE CLEANER PRIOR TO APPLYING EPDM PRIMER

4

REMOVE & REPLACE POLY BACKING ON FLASHING. FOLD FLASHING IN HALF WITH ROUNDED PORTION TURNED UP. CENTER ON CORNER & FIRMLY PRESS AGAINST VERTICAL SURFACE

5

ROLL & CREASE FLASHING TIGHTLY INTO ANGLE CHANGE & FIRMLY ROLL FLASHING ONTO THE DECK MEMBRANE

USE HEAT GUN TO WARM THE FLASHING IN COLD WEATHER

6

ROLL WITH A TWO INCH WIDE STEEL HAND ROLLER. PAY PARTICULAR ATTENTION TO THE STEP OFFS AND ANGLE CHANGES

7

ROLL STEP OFFS AND ANGLE CHANGES

8

APPLY EPDM PRIMER TO SPLICE AREA. INSTALL THE 12"x12" (30cmX30cm) SECTION OF PEEL & STICK UNCURED EPDM FLASHING CENTERED OVER PREVIOUSLY APPLIED FLASHING.

9

SEAL ALL EDGES WITH LAP SEALANT AS SHOWN

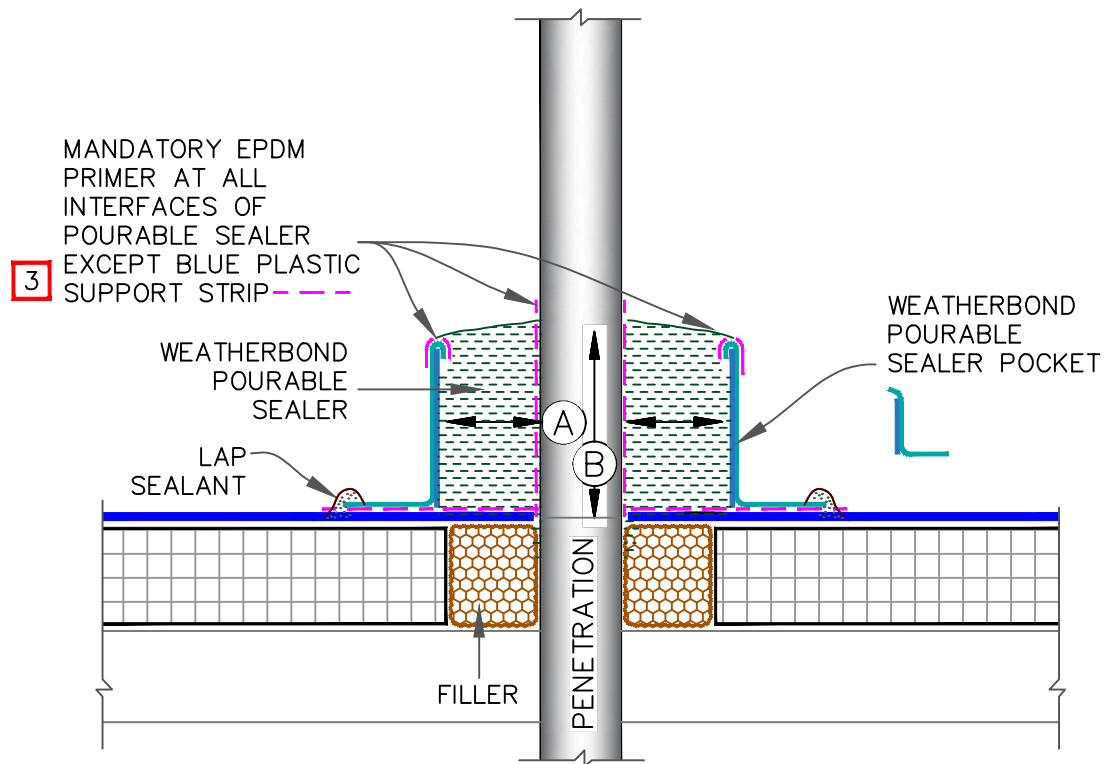

NOTES:

1. THE MAXIMUM ALLOWABLE SURFACE TEMPERATURE OF THE PENETRATION SHALL NOT EXCEED 180° F (82° C).
2. ALL DEBRIS (PAINT, RUST, LEAD, OTHER FLASHINGS, ETC.) MUST BE REMOVED FROM THE PENETRATION.
3. ALL SURFACES MUST BE PRIMED WITH EPDM PRIMER PRIOR TO APPLYING POURABLE SEALER. DO NOT PRIME THE BLUE PLASTIC SUPPORT STRIP.
4. POURABLE SEALER MUST COMPLETELY FILL POURABLE SEALER POCKET TO PREVENT PONDING OF WATER.
5. POURABLE SEALER MUST CONTACT PRIMED PEEL & STICK UNCURED FLASHING AND DECK MEMBRANE.
6. SECUREMENT IS REQUIRED FOR POURABLE SEALER POCKETS WHICH ARE GREATER THAN 18" (46cm) IN DIAMETER. REFER TO SPECIFICATIONS.
7. ON MECHANICALLY-FASTENED ROOFING SYSTEMS, ADDITIONAL MEMBRANE SECUREMENT IS REQUIRED (SIMILAR TO [WBRMA-8.1](#)) REGARDLESS OF SIZE OR DIAMETER.
8. MINIMUM 1" (2.5cm) CLEARANCE REQUIRED BETWEEN PENETRATIONS.

DIMENSIONS	cm	
(A)	1"	2.5 MIN.
(B)	2"	5 MIN.



PEEL & STICK POURABLE SEALER POCKET

- EPDM MEMBRANE
- APPROVED SUBSTRATE
- SEE NOTE

EPDM ROOFING SYSTEM

WBRC-16.1

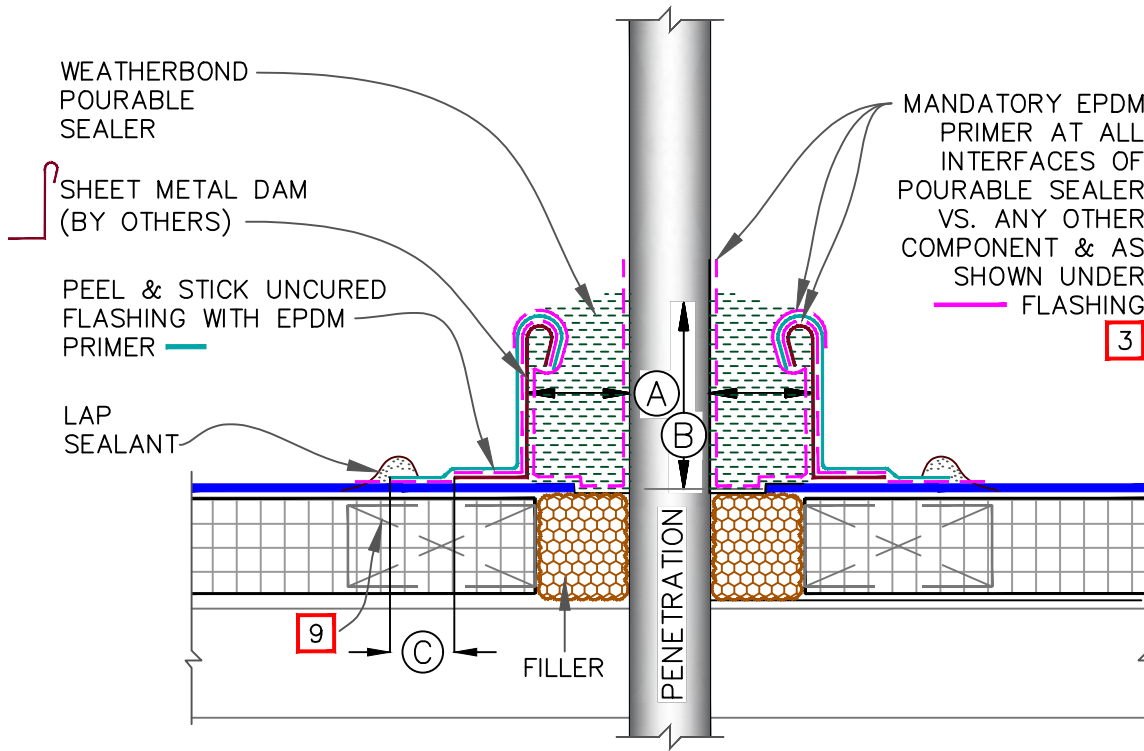

NOTES:

1. THE MAXIMUM ALLOWABLE SURFACE TEMPERATURE OF THE PENETRATION SHALL NOT EXCEED 180° F (82° C).
2. ALL DEBRIS (PAINT, RUST, LEAD, OTHER FLASHINGS, ETC.) MUST BE REMOVED FROM THE PENETRATION.
3. ALL SURFACES MUST BE PRIMED WITH EPDM PRIMER PRIOR TO APPLYING POURABLE SEALER.
4. POURABLE SEALER MUST COMPLETELY FILL POURABLE SEALER POCKET TO PREVENT PONDING OF WATER.
5. POURABLE SEALER MUST CONTACT PRIMED PEEL & STICK UNCURED EPDM FLASHING AND DECK MEMBRANE.
6. SECUREMENT IS REQUIRED FOR POURABLE SEALER POCKETS WHICH ARE GREATER THAN 18" (46cm) IN DIAMETER. REFER TO SPECIFICATIONS.
7. ON MECHANICALLY-FASTENED ROOFING SYSTEMS, ADDITIONAL MEMBRANE SECUREMENT IS REQUIRED (SIMILAR TO [DETAIL WBRMA-8.1](#)) REGARDLESS OF SIZE AND DIAMETER, UNLESS WOOD NAILERS ARE PRESENT.
8. DECK FLANGE MUST BE CONTINUOUS WITH ROUNDED CORNERS.
9. WHEN ANY ONE SIDE OF THE FIELD FABRICATED POURABLE SEALER POCKET EXCEEDS 12" (30cm), USE WOOD BLOCKING TO ANCHOR SHEET METAL.
10. MINIMUM 1" (2.5cm) CLEARANCE REQUIRED BETWEEN PENETRATIONS.

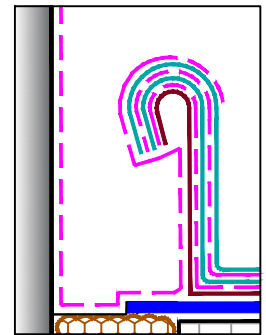

MANDATORY EPDM PRIMER AT ALL INTERFACES OF POURABLE SEALER VS. ANY OTHER COMPONENT & AS SHOWN UNDER FLASHING

DIMENSIONS	cm	
(A)	1"	2.5 MIN.
(B)	2"	5 MIN.
(C)	3"	7.5



FIELD FABRICATED POURABLE SEALER POCKET

- EPDM MEMBRANE
- APPROVED SUBSTRATE
- SEE NOTE

EPDM ROOFING SYSTEM

WBRC-16.2

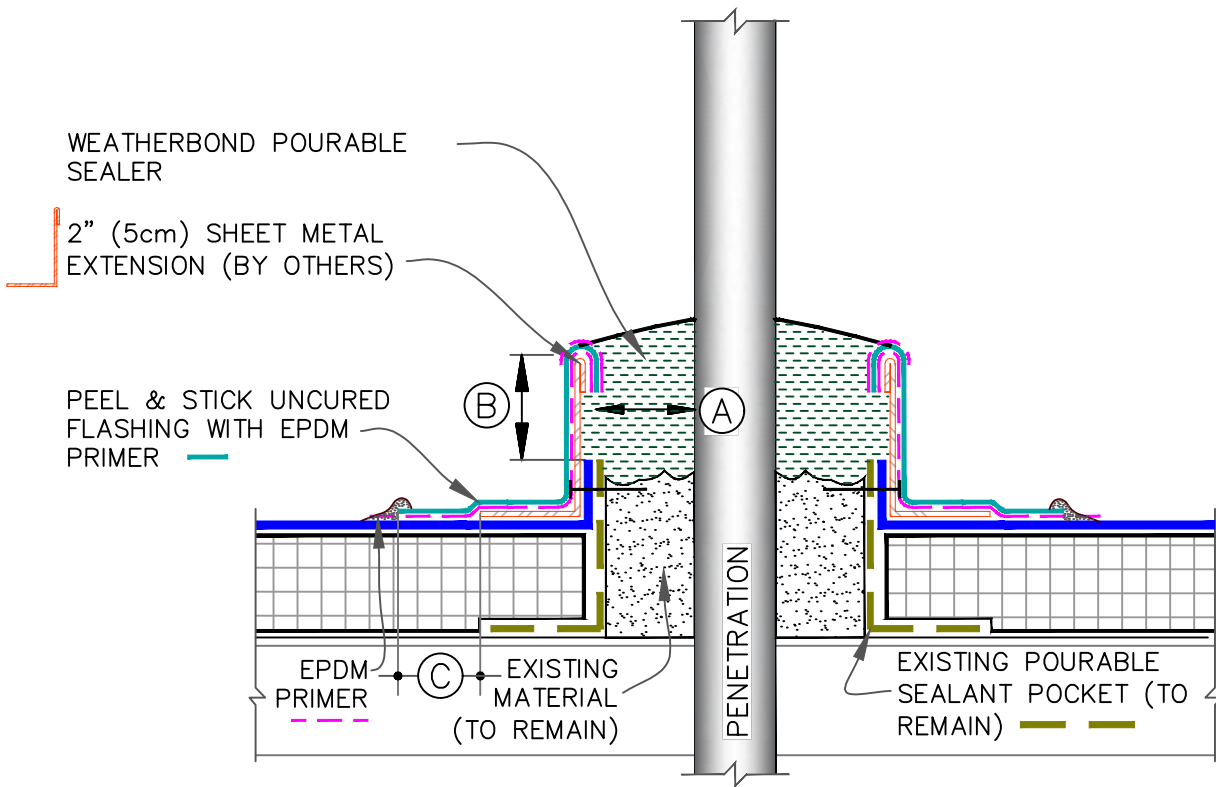

NOTES:

1. THE MAXIMUM ALLOWABLE SURFACE TEMPERATURE OF THE PENETRATION SHALL NOT EXCEED 180° F (82° C).
2. ALL DEBRIS (PAINT, RUST, LEAD, OTHER FLASHINGS, ETC.) MUST BE REMOVED FROM THE PENETRATION.
3. ALL SURFACES MUST BE PRIMED WITH EPDM PRIMER PRIOR TO APPLYING POURABLE SEALER.
4. POURABLE SEALER MUST COMPLETELY FILL POURABLE SEALER POCKET TO PREVENT PONDING OF WATER.
5. POURABLE SEALER MUST CONTACT PRIMED PEEL & STICK UNCURED EPDM FLASHING.
6. SHAPE METAL DAM TO FIT EXISTING PITCH POCKET.
7. SECUREMENT IS REQUIRED FOR POURABLE SEALER POCKETS WHICH ARE GREATER THAN 18" (46cm) IN DIAMETER. REFER TO SPECIFICATIONS.
8. ON MECHANICALLY-FASTENED ROOFING SYSTEMS, ADDITIONAL MEMBRANE SECUREMENT IS REQUIRED (SIMILAR TO [DETAIL WBRMA-8.1](#)) REGARDLESS OF SIZE OR DIAMETER.
9. MINIMUM 1" (2.5cm) CLEARANCE REQUIRED BETWEEN PENETRATIONS.

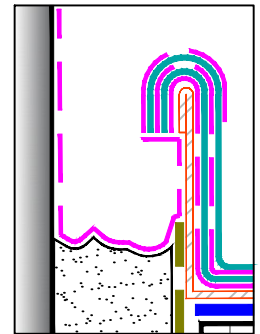

MANDATORY EPDM PRIMER AT ALL INTERFACES OF POURABLE SEALER

DIMENSIONS	cm		
(A)	1"	2.5	MIN.
(B)	2"	5	MIN.
(C)	3"	7.5	



EXTENDED POURABLE SEALER POCKET

- EPDM MEMBRANE
- APPROVED SUBSTRATE
- SEE NOTE

EPDM ROOFING SYSTEM

WBRC-16.3

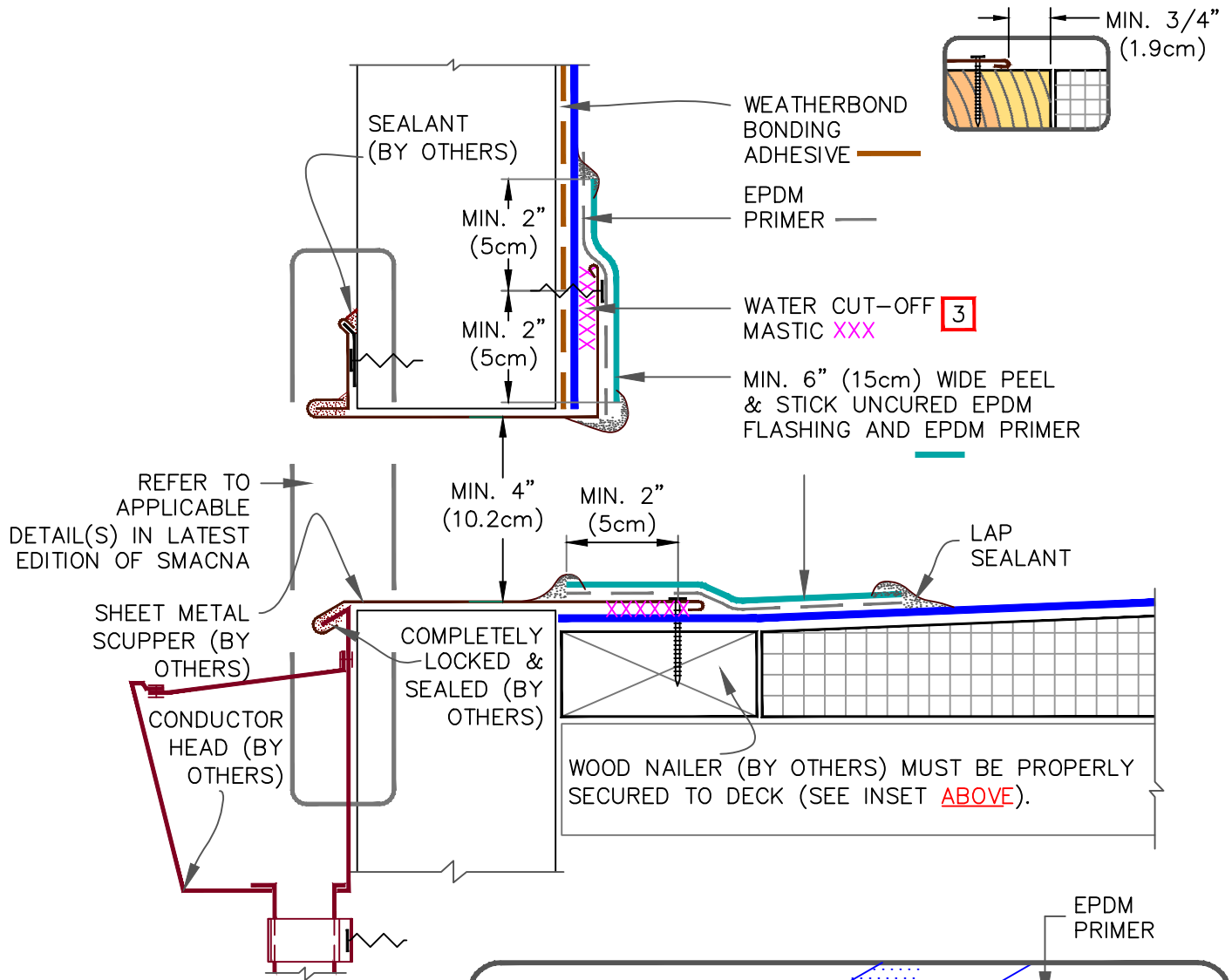

NOTES:

1. METAL SCUPPER BOX MUST HAVE CONTINUOUS FLANGES WITH ROUNDED CORNERS. SOLDER ALL SCUPPER SEAMS WATER-TIGHT.
2. WATER CUT-OFF MASTIC UNDER SCUPPER FLANGE MUST BE UNDER CONSTANT COMPRESSION.
3. CLEAN METAL FLANGE WITH WEATHERED MEMBRANE CLEANER; AND ALLOW TO DRY.
4. SCUPPERS WITHOUT A CONTINUOUS WATERTIGHT DESIGN MUST BE FLASHED IN PER [WBRC-15](#) OUTSIDE CORNER DETAILS.

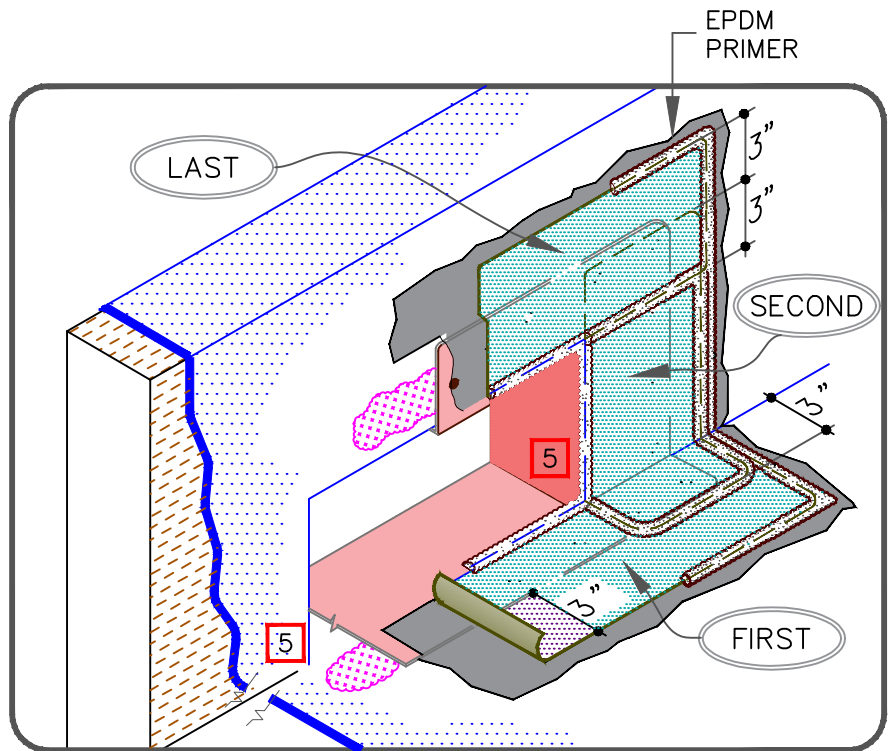

SCUPPER: SINGLE LAYER FLASHING

- ● EPDM MEMBRANE
- APPROVED SUBSTRATE
- 0 ● SEE NOTE

EPDM ROOFING SYSTEM

WBRC-18.1

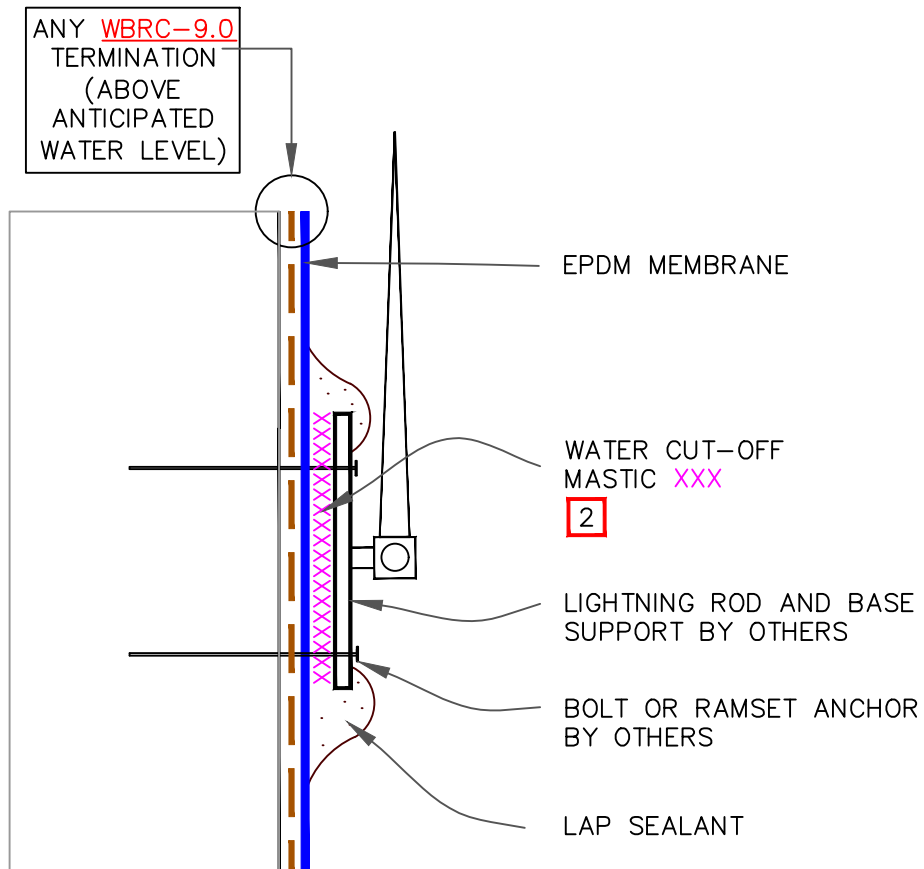



NOTES:

1. DETAIL MAY BE USED FOR ANY FASTENER PENETRATION (E.G., ACCESS LADDER, ANCHOR SUPPORT TO PARAPET).
2. WATER CUT-OFF MASTIC MUST BE UNDER CONSTANT COMPRESSION.
3. COMPLY WITH ZONING ORDNANCE AND LOCAL CODES FOR MOUNTING A LIGHTNING SYSTEM.
4. DETAIL UNACCEPTABLE FOR HORIZONTAL APPLICATIONS ON ROOF DECK.



LIGHTNING ROD AT PARAPET (VERTICAL ATTACHMENT)

-  EPDM MEMBRANE
-  APPROVED SUBSTRATE
-  SEE NOTE

EPDM ROOFING SYSTEM

WBRC-20.1

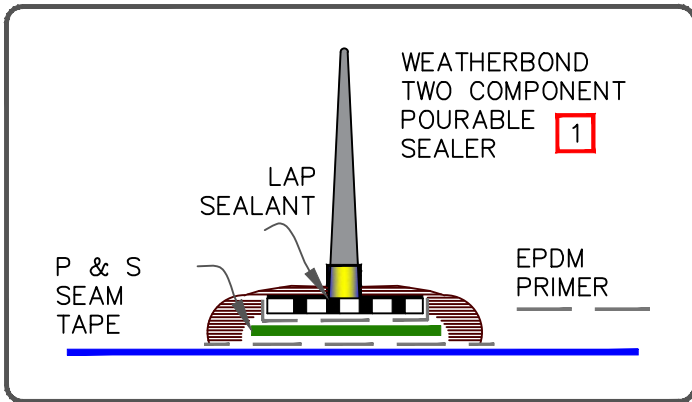

OPTION WITH PEEL & STICK SEAM TAPE ATTACHMENT

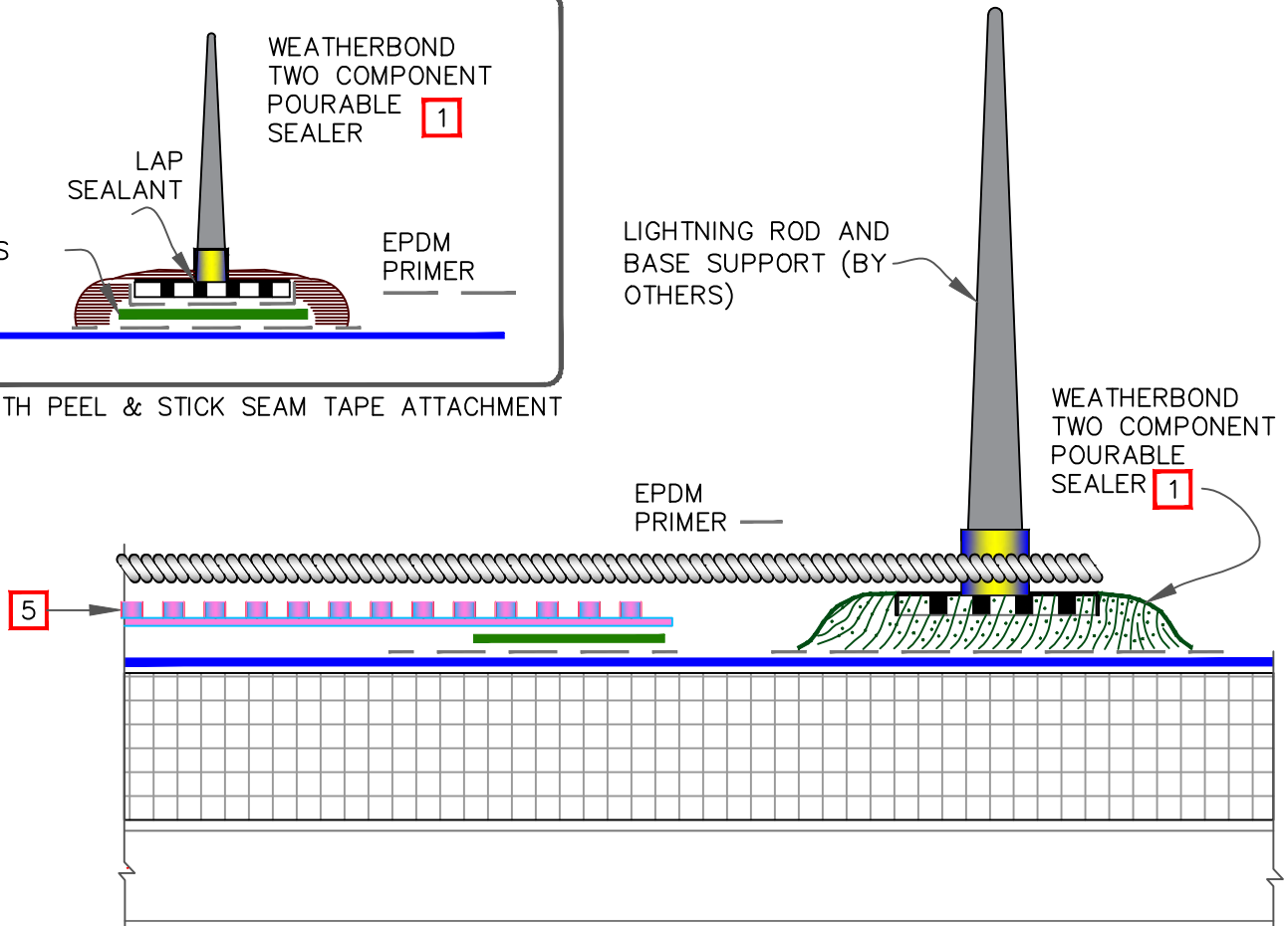

NOTES:

1. WEATHERBOND TWO COMPONENT POURABLE SEALER WITH EPDM PRIMER, OR UNIVERSAL SINGLE-PLY SEALANT.
2. CLEAN EXPOSED MEMBRANE WITH WEATHERED MEMBRANE CLEANER AND ALLOW TO DRY.
3. PRIOR TO THE APPLICATION OF POURABLE SEALER, APPLY EPDM PRIMER TO THE MEMBRANE AND LIGHTNING ROD BASE ACHIEVING A VERY THIN EVEN COAT ON BOTH SURFACES. ALLOW PRIMER TO DRY UNTIL IT IS TACK FREE.
4. COMPLY WITH ZONING ORDNANCE AND LOCAL CODES FOR MOUNTING A LIGHTNING SYSTEM.
5. PIECES OF WALKWAY PADS MAY BE INSTALLED UNDERNEATH THE BRAIDED WIRES. ENSURE, WATER FLOW IS NOT RESTRICTED AND PROVIDE PROPER GAPS.



EXAMPLE: BRAIDED WIRE IN CERTAIN COUNTRIES

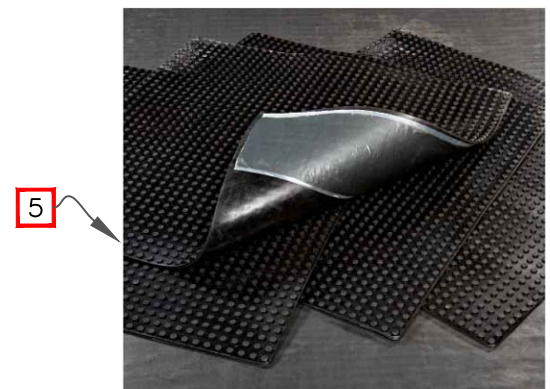

LIGHTNING ROD AT DECK LEVEL

- EPDM MEMBRANE
- APPROVED SUBSTRATE
- SEE NOTE

EPDM ROOFING SYSTEM

WBRC-20.2

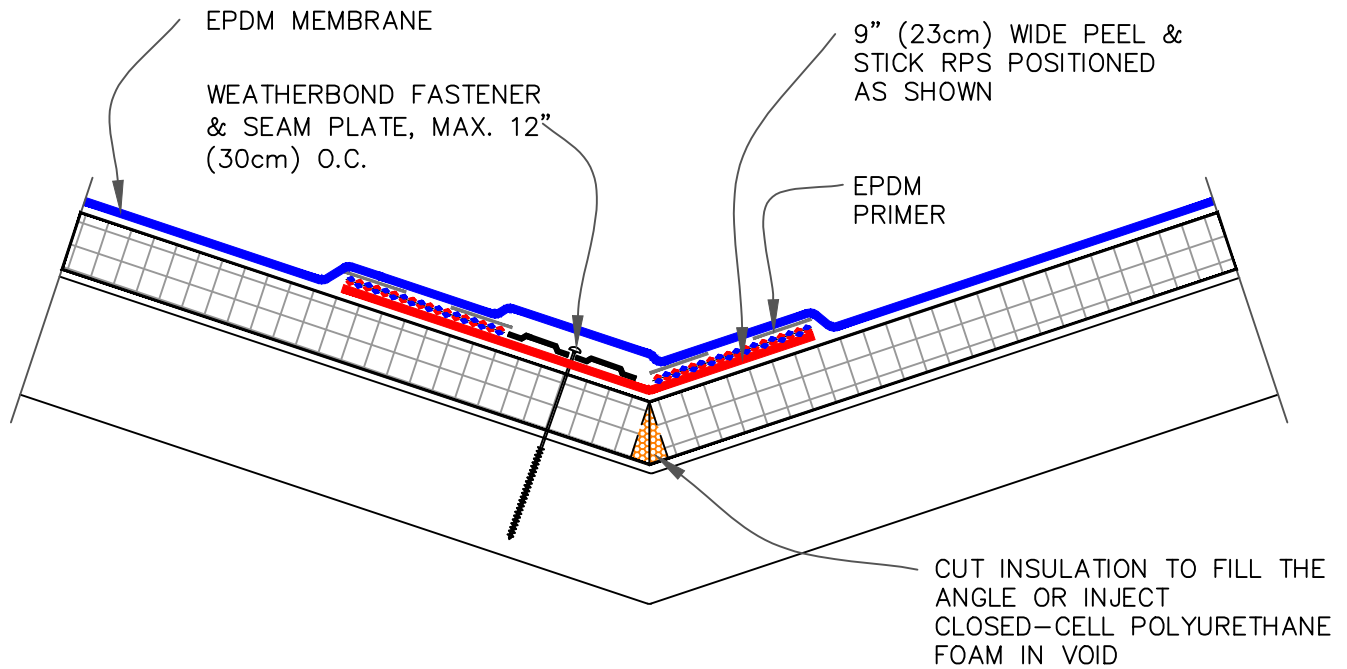



NOTES:

1. DETAIL FOR VERSIGARD/VERSIGARD-WHITE ADHERED AND VERSIGARD MECHANICALLY-FASTENED ROOFING SYSTEMS WHEN SLOPE AT VALLEY EXCEEDS 2" (5cm) IN ONE HORIZONTAL FOOT.
2. ON MECHANICALLY-FASTENED ROOFING SYSTEMS, HPWX FASTENERS AND POLYMER SEAMS ARE REQUIRED OVER STEEL DECKS.
3. EPDM PRIMER MUST BE APPLIED TO BACK SIDE OF DECK MEMBRANE PRIOR TO COMPLETING SPLICE TO QUICK APPLIED RPS.



VALLEY

-  EPDM MEMBRANE
-  APPROVED SUBSTRATE
-  SEE NOTE

EPDM ROOFING SYSTEM

WBRC-22.0

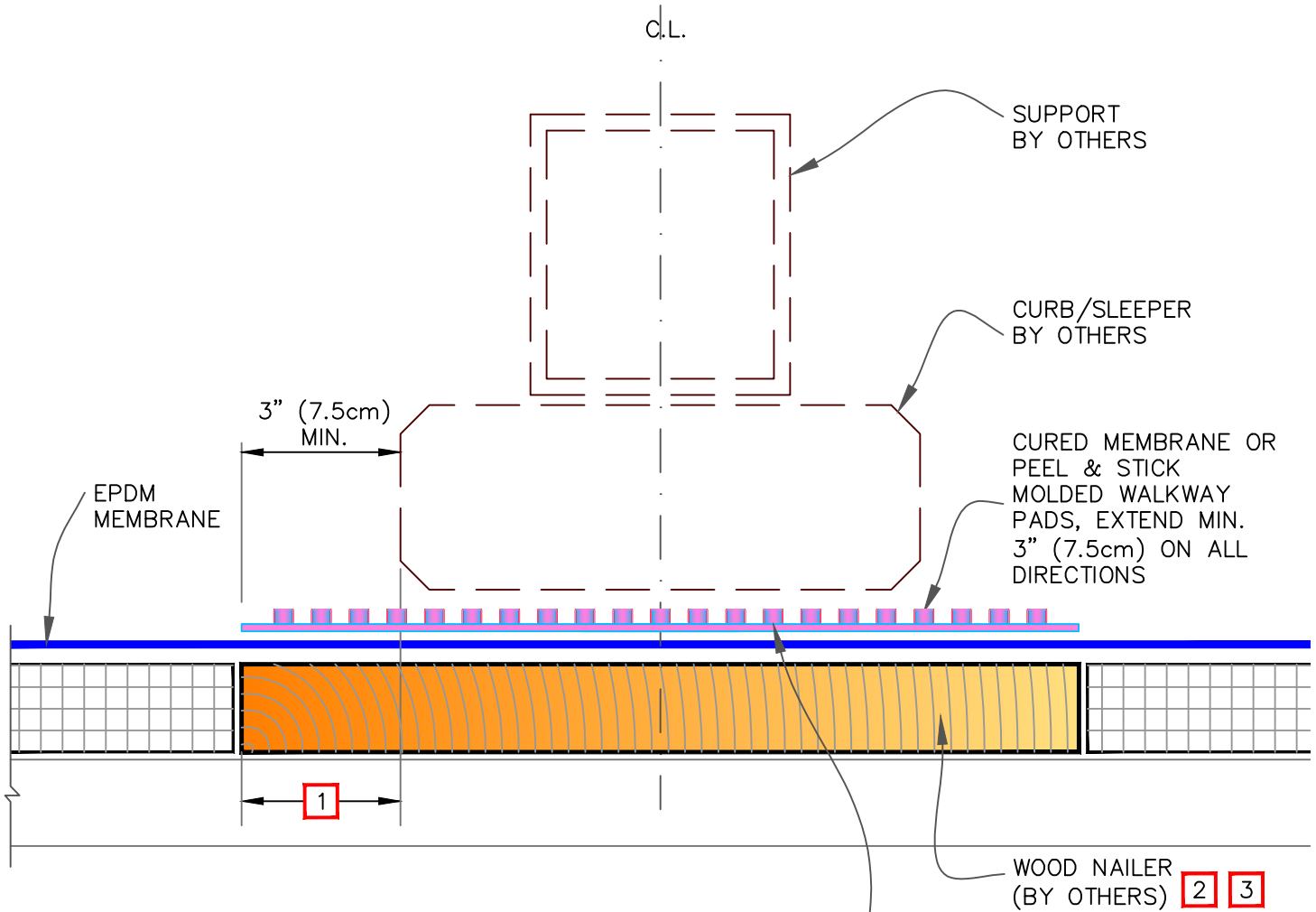

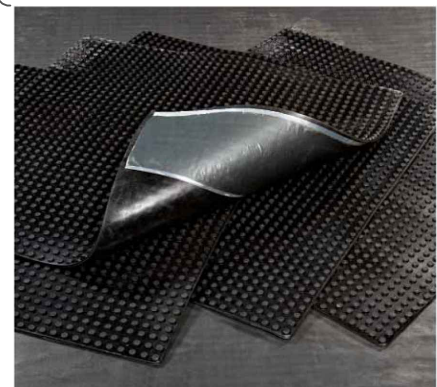

NOTES:

1. SLEEPER MUST BE LARGE ENOUGH TO SUPPORT WEIGHT OF EQUIPMENT WITHOUT INDENTING INSULATION. EXTEND WOOD NAILER OUT AS REQUIRED BY STRUCTURAL ENGINEER TO DISTRIBUTE SUBJECT LOAD OR AT LEAST EXTEND OUT MIN. 3" (7.5cm).
2. ENSURE SCREW/ANCHOR HEADS IN TOP SURFACE OF WOOD BLOCKING ARE RECESSED TO PROTECT MEMBRANE.
3. WOOD NAILERS REQUIRED IF WEIGHT OF SLEEPER MAY INDENT OR DAMAGE INSULATION.
4. CONSULT STRUCTURAL ENGINEER AND/OR SPECIFIER TO AVOID WATER PONDING DUE TO DECK DEFLECTION.



SLEEPER

-  EPDM MEMBRANE
-  APPROVED SUBSTRATE
-  SEE NOTE

EPDM ROOFING SYSTEM

WBRC-24.0

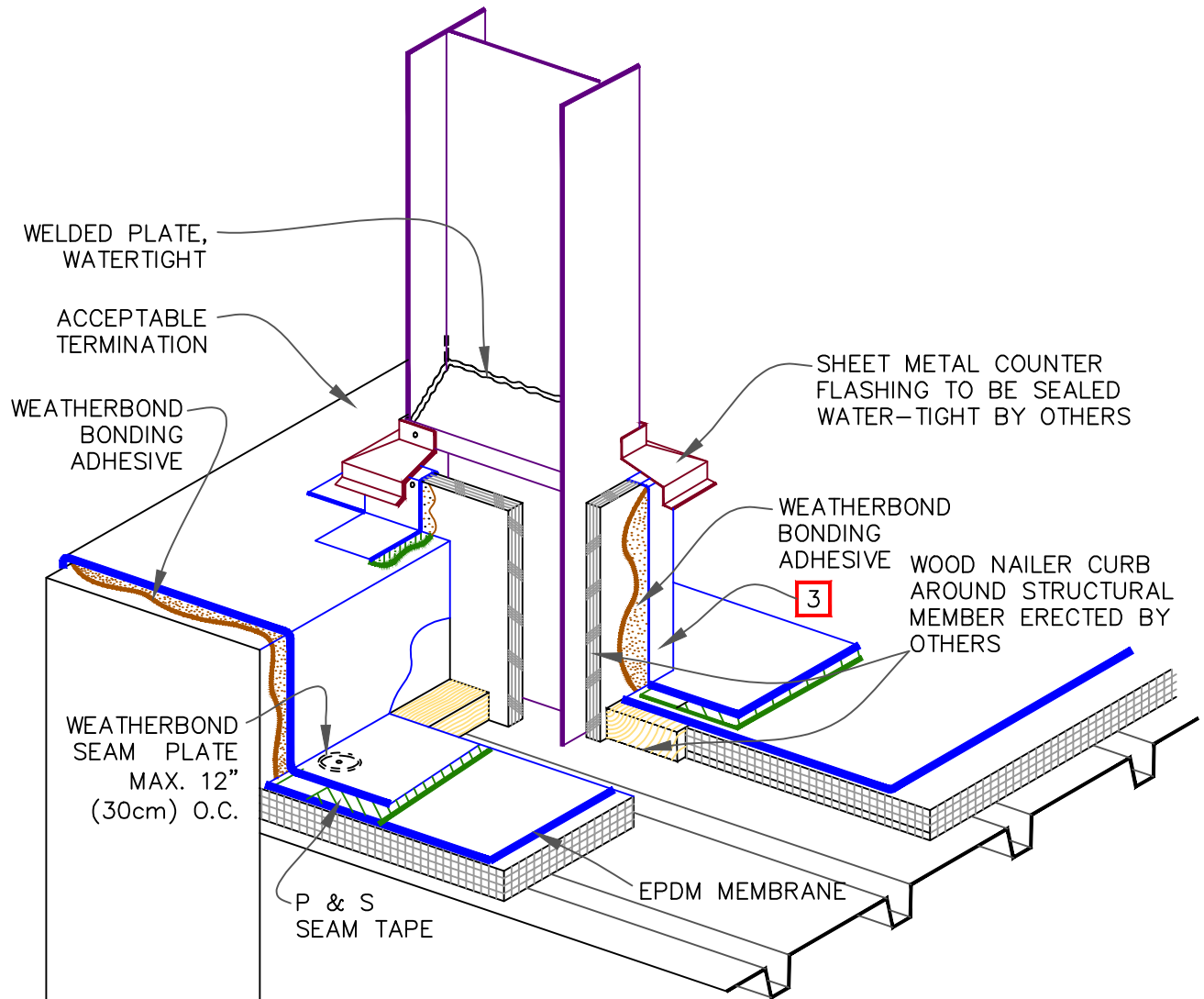



NOTES:

1. FOR PARAPET FLASHING, REFER TO DETAIL(S) [WBRC-12.](#)
2. FOR CURB FLASHING, REFER TO DETAIL(S) [WBRC-5.](#)
3. FOR CORNER APPLICATION, REFER TO DETAIL(S) [WBRC-15.](#)



I-BEAM PENETRATION

-  EPDM MEMBRANE
-  APPROVED SUBSTRATE
-  SEE NOTE

EPDM ROOFING SYSTEM

WBRC-30.0