



**WeatherBond TPO
Mechanically Attached and Fully Adhered Roofing Systems**

TABLE OF CONTENTS

January 2024

Part I-General

1.01 Description	3
1.02 General Design Considerations	3
1.03 Quality Assurance	5
1.04 System Recommendations	5

Tables

TABLE I – Mechanically Attached TPO – Membrane Fastening – Steel/Concrete Decks.....	6
TABLE II – Mechanically Attached TPO – Membrane Fastening – Plywood/OSB Decks	6
TABLE III – Mechanically Attached TPO – Membrane Fastening – Lightweight/Gypsum/Wood Fiber Decks	7
TABLE IV – Fully Adhered TPO – Underlayment/Fastening	7
TABLE V – Fully Adhered PAS TPO – Underlayment/Fastening	8
1.06 Product Delivery Storage and Handling	9

Part II – Product

2.01 Membranes	9
2.02 Insulations/Underlayments	11
2.03 Related Materials	14
2.04 Fastening Components	17
2.05 Insulation Securement Adhesive	19
2.06 Vapor/ Air Barrier.....	19
2.07 Edgings/Terminations.....	20
2.08 Roof Walkways.....	20
2.09 Other WeatherBond Accessories	21

Part III – Execution

3.01 General.....	21
3.02 Roof Deck/Substrate Criteria.....	21
3.03 Insulation/Underlayment.....	23
3.04 Insulation Attachment.....	23
3.05 Membrane Placement and Securement Criteria.....	25
3.06 Heat Welding Procedures	30
3.07 Welding Problems/Repairs.....	31
3.08 Flashings.....	31
3.09 Roof Walkways.....	34
3.10 Daily Seal.....	34

Note: In addition to information listed in this section Specifiers and contractors should reference Spec Supplement and Design Reference Sections for other pertinent information.

Installation Details.....	35
----------------------------------	-----------

This page intentionally blank



WeatherBond TPO Mechanically Attached and Fully Adhered Roofing Systems

January 2024

This section is to serve as a guide regarding the design and installation of WeatherBond's Fully Adhered and Mechanically Attached Thermoplastic Membrane Roofing Systems. Additional information essential for the design and installation of the roof system mentioned herein are also included in the Design Reference Section and also listed in the form of a Specification Supplement.

Various Tables have been included in Paragraph 1.05 citing various recommendations. Appropriate Table should be referenced to ensure proper coverage.

PART I – GENERAL

1.01 Description

A. Mechanically Attached Systems (WeatherBond TPO)

1. The **WeatherBond TPO Mechanically Attached Roofing System** incorporates 12', 10' or 8' wide, white, tan or gray 45, 60, or 80-mil thick scrim-reinforced, WeatherBond Thermoplastic Polyolefin (TPO) membrane field sheets. The Spectro-Weld Mechanically Attached Roofing System incorporates 10' or 6' wide, white, 60- or 80-mil thick scrim-reinforced Thermoplastic Polyolefin (TPO) membrane field sheets. Insulation is mechanically attached to an acceptable roof deck. WeatherBond TPO perimeter sheets (6' used with 10' and 12' wide field sheets; 4' used with 8' wide field sheets) are installed along building edges and field membrane sheets are Mechanically Attached to the roof deck with the appropriate WeatherBond fasteners and fastening plates. Adjoining sheets of WeatherBond TPO membrane are overlapped and joined together with a minimum 1-1/2" wide heat weld. Membrane fastening requirements are outlined in Tables in Paragraph 1.05 of this Specification.

B. Fully Adhered Roofing Systems (WeatherBond TPO / WeatherBond PAS TPO)

1. The **WeatherBond TPO Fully Adhered Roofing System** incorporates maximum 12' wide white, gray or tan 45, 60 or 80-mil thick scrim-reinforced WeatherBond Thermoplastic Polyolefin (TPO) membrane (also available in 16' wide white 45, 60 or 80-mil and special colors in 60-mil thick, maximum 10' wide sheets). WeatherBond Insulation is mechanically attached to the roof deck or secured with Flexible DASH Adhesive, OlyBond 500 BA, or OlyBond Spot Shot Adhesive and the membrane is fully adhered to the insulation with the appropriate WeatherBond TPO Bonding Adhesive. Adjoining sheets of membrane are overlapped approximately 2" and joined together with a minimum 1-1/2" wide heat weld.
2. The **WeatherBond PAS TPO (Peel & Stick TPO) membrane** is a heat-weldable single-ply thermoplastic polyolefin (TPO) sheet available in 10' wide, (white, tan or gray) 60 or 80-mil reinforced TPO membrane laminated to an elastomeric pressure-sensitive adhesive.

1.02 General Design Considerations

- A. The maximum recommended roof slope for Mechanically Attached Roofing Systems is 18" in one horizontal foot. There are no maximum slope restrictions for the application of the Fully Adhered Roofing System.
- B. The mechanically attached roofing system is **not acceptable** for installations on steel decks lighter than 22 gauge unless the steel deck is used in conjunction with lightweight concrete and a minimum of 360 pounds pullout per fastener is achieved with HPWX Fasteners into the steel deck below. A Fully Adhered Roofing System may be specified or refer to the Metal Retrofit Roofing System Specification, published separately for other roofing options.
- C. Certain petroleum based products, chemicals, and waste products may not be compatible with this roofing system. Contact WeatherBond for verification of compatibility and recommendations concerning an acceptable roofing assembly.

- D. Metal-Edge Systems and Copings should be designed in compliance with Section 1504.5 of the International Building Code and shall be tested in accordance with ANSI/SPRI ES-1.
- E. Concentrated loads from rooftop equipment may cause deformation of insulation/underlayment and possible damage to the membrane if proper protection is not provided. A protection course or sleepers must be specified.
- F. It is the responsibility of the building owner or his/her designated representative to verify structural load limitation. In addition, a core cut may be taken to verify weight of existing components when the roofing system is to be specified on an existing facility.
- G. For information regarding CRRC (Cool Roof Rating Council) and LEED™, refer to the applicable Technical Data Bulletins and Design Reference DR 07-22 "CRRC/LEED Information".

H. **Construction Generated Moisture / Vapor Drive**

- 1. On new construction projects, especially in cold climate regions, moisture generated due to the construction process could adversely impact various components within the roofing assembly if not addressed.
- 2. On structural concrete decks, when a vapor retarder is not used, gaps in the deck along the perimeter and around penetrations must be sealed along with vertical joints between tilt-up panels, if present, to prevent infiltration of hot humid air and possible moisture contamination resulting from condensation. This is specifically important when adhesive is used to attach the roof insulation.

NOTE: If left unaddressed, collected moisture could weaken insulation boards and facers resulting in a blow-off or increase the probability of mold growth.

I. **Drainage**

- 1. Drainage must be evaluated by the specifier in accordance with all applicable codes. Slopes may be provided by tapering the structure or through the use of tapered insulation; a sufficient number of roof drains should also be specified and properly located to allow for positive drainage. Significant ponding that could remain after 48 hours should be eliminated with the addition of auxiliary drains in low areas where ponding is anticipated.

WeatherBond specifically disclaims responsibility for the design and selection of an adequate drainage system and drain accessories. Selection must be made by the building owner or the owner's design professional.

- 2. Small incidental areas of ponded water will not impact the performance of this roofing system; however, in accordance with industry standards, the roofing assembly **should be designed to prevent ponding** of water on the roof for prolonged periods (longer than 48 hours). Good roofing practice dictates proper drainage to prevent possible excessive live load and, in the event of a roof leak, to minimize potential interior damage to the roofing assembly and to the interior of the building.
- 3. **Tapered edge strips, crickets or saddles** are recommended where periodic ponding of water may occur. When the slope of the taper exceeds 2 inches to one horizontal foot, additional membrane securement at the base of the tapered edge strip will be required.
- 4. Subject to code requirement, it is recommended that a minimum roof slope of 1/8" per horizontal foot be provided to serve long-term aesthetics. On new construction projects, roof drains should be positioned in areas where minimum deflection is anticipated. Slopes greater than 1/8" per foot it is recommended that a minimum roof slope of 1/8" per horizontal foot be provided to serve long-term aesthetics. On New Construction projects, roof drains should be positioned in areas where maximum deflection is anticipated. Slopes greater than 1/8" per foot should be considered due to possible roof deflection.

J. **Vapor Retarders**

- 1. WeatherBond does not require a vapor retarder for the protection of the membrane; however, it should be considered by the specifier for the protection of the roofing assembly (i.e. primarily insulation, underlayment and adhesives). The following criteria should be considered by the specifier:
- 2. Use of a vapor retarder to protect insulation and reduce moisture accumulation within an insulated roofing assembly, should be investigated by the specifier.
- 3. In the generally temperate climate of the United States, during the winter months, water vapor flows upward from a heated, more humid interior toward a colder, drier exterior. Vapor retarders are more commonly required in northern climates than in southern regions, where downward vapor pressure may be expected and the roofing

membrane itself becomes the vapor retarder.

K. **Retrofit - Recover Projects** (when the existing roofing material is left in place)

1. The removal of existing wet insulation and membrane must be specified. The specifier shall select an appropriate and compatible material as filler for voids created by removal of old insulation or membrane.
2. Entrapment of water between old and new membrane can damage and deteriorate new insulation/underlayment between the two membranes. **If a vapor retarder or air barrier is not specified**, WeatherBond recommends existing membrane be perforated to avoid potential moisture accumulation to allow for detection of moisture to enable the building owner to take corrective action. This can be accomplished by drilling approximately 3/4" diameter holes every 100 square feet in the existing built-up roof or single-ply membrane (excluding non-reinforced PVC membrane).
3. If total removal of existing non-reinforced PVC membrane is not specified, existing membrane may be cut into maximum 10' x 10' sections, when the new insulation or membrane underlayment is to be mechanically attached.
4. Regardless of the type of membrane or assembly selected, any loose flashings at the perimeter, roof drains and roof penetrations must be removed.

1.03 Quality Assurance

Building codes are above and beyond the intended purpose of this specification. The respective **owner** or **specifier** should consult local codes for applicable requirements and limitations. It is the responsibility of the specifier to review local, state and regional codes to determine their impact on the specified WeatherBond Roofing System.

NOTE: For code approvals information please contact WeatherBond.

- A. WeatherBond recommends the use of WeatherBond supplied products for use with WeatherBond TPO. The performance or integrity of products by others, **when selected by the specifier and accepted as compatible by WeatherBond**, is not the responsibility of WeatherBond.
- B. The solar reflectance of this roofing product may decrease over time due to environmental defacement such as dirt, biological growth, ponded water, etc. The roof should be monitored at regular intervals and maintained or cleaned when necessary to assure the maximum solar reflectance.
- C. Refer to the Design Reference DR-07-22 "CRRC/LEED Information" for information. (i.e. solar emittance, solar reflectance and recycled content).

1.04 System Recommendations

- A. See Tables Below for information regarding Systems and Design Criteria:

1. **TABLE I - Mechanically Attached Roofing Systems – TPO Membrane Fastening Criteria - Steel/Concrete Decks** Identifies fastening density, field membrane width and number perimeter sheets required for various wind zones.
2. **TABLE II - Mechanically Attached Roofing Systems – TPO Membrane Fastening Criteria – Plywood / OSB Decks** Identifies fastening density, field membrane width and number perimeter sheets required for the various wind zones.
3. **TABLE III - Mechanically Attached Roofing Systems – TPO Membrane Fastening Criteria – Lightweight Insulating Concrete over Steel/Gypsum/Cementitious Wood Fiber Decks** Identifies fastening density, field membrane width and number perimeter sheets required for the various wind zones.
4. **TABLE IV-Fully Adhered Roofing Systems - Underlayment and Fastening Density for TPO Assemblies** Identifies recommended underlayments for fully adhered roofing systems based on the various wind speed coverages available. The Table also identifies fastening density or adhesive bead spacing and required edge terminations.
5. **TABLE V – Fully Adhered Roofing Systems - Underlayment and Fastening Density for WeatherBond PAS Assemblies** Identifies required underlayments for fully adhered roofing systems. The Table also identifies fastening density or adhesive bead spacing and required edge terminations.

**TPO Membrane Fastening Criteria
for Mechanically Attached Roofing Systems
22 GA. Steel Deck or Structural Concrete Only**

Table I

Peak Gust Wind Speed	Max. Building Height	Min. Number of Perimeter Sheets			Field* Membrane Width	Perimeter* Sheet Width	Fastening Density* (Field & Perimeter Sheets)
		Building Distance from Coastline					
		Greater than 7 miles	3 to 7 miles	Less than 3 miles			
55 MPH	Up to 60'	1	2	3	12' or 10'	6'	12" O.C.
					8'	4'	12" O.C.
	61' to 100'	2	2	3	10'	6'	** See Note
					8'	4'	12" O.C.

*Using HPWX Fasteners for steel decks and MP 14-10 or CD-10 for structural concrete decks.

** Structural Concrete Decks use 12" O.C. spacing utilizing MP 14-10 or CD-10. Steel Decks use 6" O.C. utilizing HPWX Fasteners. Steel Decks use 12" O.C. spacing utilizing HPW-XL Fasteners.

**TPO Membrane Fastening Criteria
for Mechanically Attached Roofing Systems
Plywood / OSB Decks**

Table II

Peak Gust Wind Speed	Deck Type	Projected Pull-Out Values	Min. Number of Perimeter Sheets		Field Membrane Width	Perimeter Sheet Width	Fastening Density (Field & Perimeter Sheets)
			Building Distance from Coastline				
			Greater than 7 miles	Less than or equal to 7 miles			
55 MPH	7/16" OSB	210 lbs	2	3	10'	6'	9" O.C.
			2	3	8'	4'	12" O.C.
	15/32" 3-Ply Plywood	240 lbs	2	3	8'	4'	12" O.C.
	15/32" 5-Ply Plywood	530 lbs	1	1	10'	6'	12" O.C.
	5/8" OSB *	310 lbs	2	3	10'	6'	12" O.C.
			2	3	8'	4'	12" O.C.

**TPO Membrane Fastening Criteria
for Mechanically Attached Roofing Systems
Lightweight Insulating Concrete over Steel/Gypsum/Cementitious Wood Fiber**

Peak Gust Wind Speed	Building Height 50' Max.	Min. Number of Perimeter Sheets			Field Membrane Width	Perimeter Sheet Width	Fastening Density (Field & Perimeter Sheets)
		Building Distance from Coastline					
	Deck Type	Greater than 7 miles	3 to 7 miles	Less than 3 miles			
55 MPH	Lightweight Concrete over Steel Deck	2	3 (1)	N/A	12'	6'	12" O.C.
		1	2	4	10'	6'	12" O.C.(2)
		1	2	3	8'	4'	12" O.C.(3)
	Gypsum Deck or Cementitious Wood Fiber	2 (3)	3	N/A	10'	6'	9" O.C.
		2 (3)	3	4 (4)	8'	4'	12" O.C.

N/A is Not Acceptable

- (1) Fastening Density must be secured 6" O.C.
- (2) For Buildings 51' to 75' with 10' field sheets – Fastening Density must be secured 9" O.C.
- (3) Acceptable for Buildings up to 75' in height.
- (4) Fastening Density must be secured 9" O.C.

Additional Design Considerations

- 1-Membrane configuration and fastening density in Table above is based on HPWX Fasteners penetrating metal pan below Lightweight Insulating Concrete and for Polymer Gyptec Fasteners engaging into Gypsum and Cementitious Fiber Decks.
- 2-See Design Reference DR-06-22 "Withdrawal Resistance Criteria" for more information.

**Underlayment/Insulation & Required Attachment Assemblies
for TPO Fully Adhered Roofing Systems**

Table IV

Other Requirements are Listed in Additional Design Considerations following this Table

Peak Gust Wind Speed	Minimum Membrane Underlayment*	Insulation Attachment		Metal Edging	
		# of Fasteners per 4' x 8' board size (1)	Adhesive Ribbon Spacing for 4' x 4' size board		
			Field		Perimeter
55 MPH	1" (20 psi) Polyisocyanurate	16 (4)	12" (2)(3)	6" (2)	TPO Drip Edge
	1-1/2" (20 psi) Polyisocyanurate	10			
	2" (20 psi) Polyisocyanurate	8			
	1/2" XFP HD	12			
	1/4" DensDeck Prime or 1/4" Securock (5)	12			

*For Direct Application over Wood Decks and Lightweight Cellular Concrete, Refer to Roof Deck & Substrate Criteria Table.

- (1) For Building heights between 51'-100', enhance 12'-wide perimeter with 50% more fasteners and plates.
- (2) Gravel Surface BUR - Field @ 6" O.C. / Perimeter @ 4" O.C.
- (3) Steel Decks - Field & Perimeter @ 6" O.C.
- (4) Reduced fastening (11 fasteners per 4 x 8 board) is acceptable on Reroof/No Tear off projects with a maximum roof height of 40'.
- (5) Cover boards must be installed over a min. 1" thick approved WeatherBond Insulation.

Additional Design Considerations

- 1 – Refer to Table I in paragraph 1.05 for available options and applicable membrane thicknesses.
- 2 - Building height shall not exceed 100*
- 3 - Local Wind Zone per ASCE 7 shall not exceed 130 mph*
- 4 - Acceptable decking: 22-gauge or heavier steel, structural concrete, 1-1/2" wood plank, or 3/4" plywood.

* Projects where building height exceeds 100' or wind speed exceeds 130 mph, shall be submitted to WeatherBond for review.

Underlayment/Insulation & Required Attachment Assemblies for WeatherBond PAS TPO Fully Adhered Roofing Systems

Table V

Other Requirements are Listed in Additional Design Considerations following this Table

Peak Gust Wind Speed	Minimum Membrane Underlayment	Insulation Attachment		Metal Edging	
		# of Fasteners per 4' x 8' board size (1)	Adhesive Ribbon Spacing for 4' x 4' size board		
			Field		Perimeter
55 MPH	1" (20 psi) Polyisocyanurate	16 (5)	12" (2)(3)	6" (2)	TPO Drip Edge
	1-1/2" (20 psi) Polyisocyanurate	10			
	2"(20 psi) Polyisocyanurate	8			
	1/2" XFP HD	12			
	1/4" DensDeck Prime or 1/4" Securock (4)				
	2" (1.25 lb/density) Insulfoam SP				

- (1) For Building heights between 51'-100', enhance 12'-wide perimeter with 50% more fasteners and plates.
- (2) Gravel Surface BUR - Field @ 6" O.C. / Perimeter @ 4" O.C.
- (3) Steel Decks - Field & Perimeter @ 6" O.C.
- (4) Cover boards must be installed over a min. 1" thick approved WeatherBond Insulation.
- (5) Reduced Fastening (11 fasteners per 4 x 8 board) is acceptable on Reroof / No Tear off projects with a maximum roof height of 40'.

Additional Design Considerations

- 1 - Minimum membrane thickness 60-mil WeatherBond PAS TPO
- 2 - Building height shall not exceed 100'
- 3 - Local Wind Zone per ASCE 7 shall not exceed 130 mph*
- 4 - Acceptable decking: 22-gauge or heavier steel, structural concrete, 1-1/2" wood plank, or 3/4" plywood.
- 5 - All "T-joints" must be overlaid with appropriate flashing material or WeatherBond "T-Joint" covers.

- B. The formation or presence of mold or fungi in a building is dependent upon a broad range of factors including, but not limited to, the presence of spores and nutrient sources, moisture, temperatures, climatic conditions, relative humidity, and heating/ventilating systems and their maintenance and operating capabilities. These factors are beyond the control of WeatherBond and WeatherBond shall not be responsible for any claims, repairs, restoration or damages relating to the presence of any irritants, contaminants, vapors, fumes, molds, fungi, bacteria, spores, mycotoxins, or the like in any building or in the air, land, or water serving the building.

1.06 Product, Delivery, Storage and Handling

- A. Deliver materials to the job site in the original, unopened containers.
- B. When loading materials onto the roof, the Contractor must comply with the requirements of the specifier/owner to prevent overloading and possible disturbance to the building structure.
- C. Job site storage temperatures in excess of 90° F (32° C) may affect shelf life of curable materials (i.e., adhesives and sealants).
- D. When the temperature is expected to fall below 40° F (4° C), outside storage boxes should be provided on the roof for temporary storage of liquid adhesives and sealants. Adhesive and sealant containers should be rotated to maintain their temperature above 40° F (4° C).
- E. Do not store adhesive containers with opened lids due to the loss of solvent that will occur from flash-off.
- F. Store WeatherBond membrane on provided pallets in the original undisturbed plastic wrap in a cool, shaded area and cover with light-colored, breathable tarpaulins.
- G. Insulation/underlayment must be stored so that it is kept dry and is protected from the elements. Store insulation on a skid and completely cover with a breathable material such as tarp or canvas. If the insulation is lightweight, it should be weighted to prevent possible wind damage.

Part II – PRODUCTS

2.01 Membranes

A. WeatherBond TPO Membranes

- 1. General
 - a) WeatherBond TPO Membrane meets or exceeds the requirements of ASTM D6878, standard specification for Thermoplastic Polyolefin Based Sheet Roofing. In addition to the physical properties listed below, refer to the WeatherBond TPO Membrane Technical Data Bulletin for Cool Roof Rating Council (CRRC) and LEED™ radiative properties as well as U.S.E.P.A. Toxic Leachate Testing and dynamic puncture resistance.
 - b) The WeatherBond TPO membrane (white and tan) meets the CRRC (California Roof Rating Council) requirement for reflectance and emittance. When tested in accordance with ASTM C1549, the material has an initial reflectance of .79 and a 3-year aged reflectance of .70. The material has also been tested for emittance in accordance with ASTM C1371. An initial emittance of .90 and a 3-year aged emittance of .86 were achieved.
 - c) The WeatherBond TPO membrane (white) meets the emittance requirements set forth by the USGBC (US Green Building Council) for their LEED (Leadership in Energy and Environmental Designs) Program. When tested in accordance with ASTM E408, an emittance of .95 was achieved and an SRI (solar reflectance index) of 110 was calculated using ASTM E1980.
- 2. WeatherBond 45- or 60-mil thick Reinforced Thermoplastic Polyolefin (TPO) membrane, WeatherBond PAS (Peel & Stick) 60- or 80-mil thick Reinforced Thermoplastic Polyolefin (TPO) membrane and WeatherBond 80-mil thick Reinforced Thermoplastic Polyolefin (TPO) conforms to the following physical properties. WeatherBond PAS TPO (white, tan or gray) membrane is available in 10' wide by 50' or 100' long rolls and WeatherBond TPO (Standard and HS) membrane available in field sheets in rolls 16', 12', 10' or 8' wide by 100' long. Perimeter membrane sheets are available in widths of 5' or 6' (used with 12' and 10' wide field sheets) or 4' (used with 8'

wide field sheets) by 100' long. WeatherBond TPO Membrane is available in white, gray or tan. (16' wide WeatherBond Membrane only available in white). Special Color TPO membrane is available in 5 colors (Medium Bronze, Rock Brown, Terra Cotta, Slate Gray and Patina Green) in 60-mil field sheets in rolls 5' or 10' wide by 100' long and 80-mil field sheets in 10' wide by 100' long. Special Color TPO is a special order product and may require a lead time.

OPTION: 60- or 80-mil, white, WeatherBond TPO (white, tan or gray) reinforced membrane is available with an optional APEEL Protective Film. APEEL Protective Film can be left in place for up to 90 days without affecting the integrity of the film, guarding the TPO membrane's surface from scuffs and dirt accumulation during installation. Durable and easy to remove, APEEL Protective Film improves aesthetics and long-term reflectivity. Available 4', 6', 8', 10' and 12' widths by 100' long rolls. Some sizes and colors of WeatherBond PAS TPO with APEEL require a minimum order of 200 squares and 2-3 week lead time. Also available, APEEL 6" Cover Tape, allowing 100% coverage of the TPO surface. APEEL Cover Tape rolls are 1,640 feet long.

NOTE: WeatherBond TPO High Slope (HS)(also known as Extra Slope (ES)) and Special Color TPO Membrane is specially formulated with higher fire retardancy to accommodate steep slope roof conditions.

PHYSICAL PROPERTY	ASTM D6878 Requirement	45-mil Std & HS	60-mil Std & HS	60-mil PAS TPO	80-mil Plus
Tolerance on nominal thickness, % ASTM D751 test method	+15, -10	± 10	± 10	± 10	± 10
Thickness over scrim, in. (mm) ASTM D6878 optical method, average of 3 areas	0.012 min. (0.305)	0.018 typical (0.457)	0.024 typical (0.610)	0.024 typical (0.610)	0.034 typical (0.864)
Breaking strength, lbf (kN) ASTM D751 grab method	220 (976 N) min.	225 (1.0) min. 320 (1.4) typ.	250 (1.1) min. 360 (1.6) typ.	250 (1.1) min. 360 (1.6) typ.	350 (1.6) min. 425 (1.9) typ.
Elongation break of reinforcement, % ASTM D751 grab method	15 min.	15 min. 25 typ.	15 min. 25 typ.	15 min. 25 typ.	15 min. 25 typ.
Tearing strength, lbf (N) ASTM D751 proc. B 8 by 8 in.	55 (245) min.	55 (245) min. 130 (578) typ.	55 (245) min. 130 (578) typ.	55 (245) min. 130 (578) typ.	55 (245) min. 130 (578) typ.
Brittleness point, °F (°C) ASTM D2137	-40 (-40) max.	-40 (-40) max. -50 (-46) typ.	-40 (-40) max. -50 (-46) typ.	-40 (-40) max. - 50 (-46) typ.	-40 (-40) max. - 50 (-46) typ.
Linear dimensional change, % ASTM D1204, 6 hours at 158 °F	± 1 max.	± 1 max. -0.2 typ.	± 1 max. -0.2 typ.	± 0.5 max. -0.2 typ.	± 1 max. -0.2 typ.
Ozone resistance, no cracks 7X ASTM D1149, 100 pphm, 168 hrs	Pass	Pass	Pass	Pass	Pass
Water absorption resistance, mass % ASTM D471 top surface only 166 hours at 158 °F water	± 3.0 max.	3.0 max. 2.0 typ.	3.0 max. 2.0 typ.	4.0 max. 2.0 typ.	3.0 max. 2.0 typ.
Factory seam strength, lbf /in. (kN/m) ASTM D751 grab method	66 (290) min.	66 (290) min.	66 (290) min.	66 (290) min.	66 (290) min.
Field seam strength, lbf /in. (kN/m) ASTM D1876 tested in peel	No requirement	25 (4.4) min. 50 (8.8) typ.	25 (4.4) min. 60 (10.5) typ.	25 (4.4) min. 60 (10.5) typ.	40 (7.0) min. 70 (12.3) typ.
Water vapor permeance, Perms ASTM E96 proc. B	No requirement	0.10 max. 0.05 typ.	0.10 max. 0.05 typ.	0.10 max. 0.05 typ.	0.10 max. 0.05 typ.
Puncture resistance, lbf (kN) FTM 101C, method 2031 (see supplemental section)	No requirement	250 (1.1) min. 325 (1.4) typ.	300 (1.3) min. 350 (1.6) typ.	300 (1.3) min. 350 (1.6) typ.	400 (1.8) min. 450 (2.0) typ.
Properties after heat aging ASTM D573, 670 hrs at 240 °F Breaking strength, % retained Elongation reinf., % retained Tearing strength, % retained Weight change, %	90 min. 90 min. 60 min. ± 1.0 max.	90 min. 90 min. 60 min. ± 1.0 max.	90 min. 90 min. 60 min. ± 1.0 max.	90 min. 90 min. 60 min. ± 1.0 max.	90 min. 90 min. 60 min. ± 1.0 max.

2.02 Insulations/Underlayments

A. General

1. Roof insulation thickness must be determined by the thermal value required for each project and may be subject to code approval limitations. On projects where a vapor retarder is used, the specifier must calculate insulation thickness to ensure the temperature at the vapor retarder will not fall below the calculated dew point.
2. Multiple layers of insulation are recommended with all joints staggered between layers.
3. For minimum recommended R-Values, previously published by American Society of Heating and Air-Conditioning Engineers (ASHRAE), consult local building code official for applicable requirements.
4. For Insulation fastening pattern and densities refer to WeatherBond Applicable Details and Design Reference DR-05-22 "Insulation Fastening Patterns".
5. When new insulation or cover boards are specified, the use of WeatherBond Insulation and WeatherBond marketed cover board is required. Any of the WeatherBond Insulation/Underlayment may be specified subject to design restrictions included with each of the following tables.

B. WeatherBond Polyisocyanurate

Table B1 Polyisocyanurate (See below for product descriptions)				
Insulations / Underlayment	Minimum Thickness	ASTM	Roofing System Acceptability	
			Fully Adhered	Mechanically Fastened
WeatherBond XP Polyiso	*1.5"	C1289, Type II, Class 1, Grade 2 or 3	√	√
WeatherBond XFP Polyisocyanurate	*1.5"	C1289, Type II Class 2, Grade 2 or 3	√	√
WeatherBond XFP HD Polyiso Composite (XFP HD)	2"	C1289, Type IV, Class 2, Grade 2 or 3	√	√
WeatherBond XP-NB Polyiso Composite (OSB)	1.5"	C1289, Type V, Class 1, Grade 2 or 3	√	N/A
Design Restrictions				
-Maximum Flute Spanability shall be limited to 2-5/8" when 1" Minimum Polyiso Insulation is to be used. -Minimum thickness of insulation board may be restricted by wind speed coverage, refer to Tables in Paragraph 1.05. *1.5 minimum for fully adhered systems. 1" minimum for mechanically attached systems or as a base layer for fully adhered.				
Notes: N/A = Not Acceptable √ = Acceptable				

NOTE: XFP HD Cover Board is listed in Paragraph C4 below.

2. **WeatherBond XP Polyiso** – A foam core insulation board covered on both sides with a medium weight fiber-reinforced felt facer meeting ASTM C 1289-06, Type II, Class 1, Grade 2 (20 psi) or Grade 3 (25 psi). The product is available in 4' x 8' standard size with a thickness from 1 to 4 inches. 4' x 4' tapered panels are also available.
3. **WeatherBond XFP Polyisocyanurate**– A foam core insulation board covered on both sides with a coated glass fiber mat facer meeting ASTM C 1289-06, Type II, Class 2, Grade 2 (20 psi) or Grade 3 (25 psi). The product is available in 4' x 8' standard size with a thickness from 1 to 4 inches. 4' x 4' tapered panels are also available.
4. **WeatherBond XFP HD Cover Board** – Composite insulation panel comprised of ½-inch high-density Polyiso cover board laminated during the manufacturing process to XFP rigid Polyiso roof insulation meeting ASTM C1289 Type IV, Class 2, Grade 2 (20 psi) or Grade 3 (25 psi). Available in 4' x 8' boards with thickness from 2" to 4.5". 4' x 4' panels are also available.

5. **WeatherBond XP-NB Polyiso** – XP Polyiso insulation bonded on the bottom side with a medium weight fiber-reinforced felt face and laminated with a top surface of 7/16" or 5/8" thick Oriented Strand Board (OSB) meeting ASTM C1289, Type V, Class1 Grade 2 (20 psi) or Grade 3 (25 psi). Available in 4' x 8' boards with thickness from 1-1/2" to 4".

C. **EPS : Expanded Polystyrene**

Table C1 EPS : Expanded Polystyrene (See below for product descriptions)				
Insulations / Underlayment	Minimum Thickness	ASTM	Roofing System Acceptability	
			Adhered	Mechanically Fastened
InsulFoam I	1"	C578 Type I	N/A	√ (1)(3)
InsulFoam VIII	.75"	C578 Type VIII	N/A	√ (1)
InsulFoam II	.75"	C578 Type II	N/A	√ (1)
InsulFoam IX	.75"	C578 Type IX	N/A	√ (1)
InsulFoam HD Composite (XFP HD)	1.5"	C578 Type (I, VIII, II, or IX)	√	√
InsulLam (Various Cover Boards)	1.5"	C578 Type (I, VIII, II, or IX)	√	N/A
InsulFoam SP	1"	C578 Type VIII	N/A	√
InsulFoam SP	2"	C578 Type VIII	(2)	√
Design Restrictions				
-Local Codes must be consulted regarding the acceptance of expanded insulation directly over steel decks. When specified, minimum thickness shall be designated by the manufacturer. -Expanded polystyrene roof insulations cannot be installed directly over coal-tar pitch roof surfaces or existing PVC membranes. A separation layer of minimum 1/2" XFP HD, Recovery Board or Polyiso Insulation shall be used. (1) WeatherBond PVC Membrane is not acceptable for this application. (2) May be used as a substrate for WeatherBond PAS TPO membrane Only. (3) Minimum 1.25 lbs/cubic ft (pcf) density required for WB TPO Membrane (White Membrane Only)				
Notes: N/A = Not Acceptable √ = Acceptable				

NOTE: R-Tech Fanfold Recover Board is listed in Paragraph E7 below.

NOTE: Insulation boards listed in 'a' through 'd' may be specified beneath SecurShield HD, WB Recovery Board, Dens-Deck Prime or Securock

- InsulFoam I (EPS: Expanded Polystyrene)** – A closed-cell lightweight expanded polystyrene (EPS) that meets ASTM C578, Type I. Nominal density of 1.0 lbs/cubic ft (pcf) available in 4' x 4' or 4' x 8' sizes with thickness from 1/4" to 40". Custom lengths, widths and tapered boards are available.
- InsulFoam VIII (EPS: Expanded Polystyrene)** – A closed-cell lightweight expanded polystyrene (EPS) that meets ASTM C578, Type VIII. Nominal density of 1.25 lbs/cubic ft (pcf) available in 4' x 4' or 4' x 8' sizes with thickness from 1/4" to 40". Custom lengths, widths and tapered boards are available.
- InsulFoam II (EPS: Expanded Polystyrene)** – A closed-cell lightweight expanded polystyrene (EPS) that meets ASTM C578, Type II. Nominal density of 1.5 lbs/cubic ft (pcf) available in 4' x 4' or 4' x 8' sizes with thickness from 1/4" to 40". Custom lengths, widths and tapered boards are available.
- InsulFoam IX (EPS: Expanded Polystyrene)** – A closed-cell lightweight expanded polystyrene (EPS) that meets ASTM C578, Type IX. Nominal density of 2.0 lbs/cubic ft (pcf) available in 4' x 4' or 4' x 8' sizes with thickness from 1/4" to 40". Custom lengths, widths and tapered boards are available.
- InsulFoam HD Composite** – InsulFoam expanded polystyrene (EPS) insulation laminated with a top surface of 1/2" thick XFP HD. Available in 4' x 8' boards with thickness from 1-1/2" to 7".
- InsulLam** – InsulFoam expanded polystyrene (EPS) insulation laminated with a top surface of 7/16" or 5/8" thick Oriented Strand Board (OSB), 1/2" DensDeck Prime, 1/2" Securock, or 1/2" Recovery Board. Available in 4' x 8' boards with thickness from 1-1/2" to 7".
- InsulFoam SP** – A closed-cell lightweight expanded polystyrene (EPS) with a factory-laminated fiber glass facer. Nominal density of 1.25 lbs/cubic ft (pcf), available in 4' x 8' size, and meets ASTM C578, Type VIII. Designed for low-sloped roof applications that employ mechanically attached or WeatherBond PRO PAS TPO membranes.

- D. **XPS: Extruded Polystyrene** – Dimensionally stable with high thermal and low water absorption performance capability. XPS is available in varying compressive strengths thicknesses and sizes. Refer to specific Technical Data Bulletins for physical properties and additional technical information.

Table D1 XPS: Extruded Polystyrene (See below for product descriptions)				
Insulations / Underlayment	Minimum Thickness	ASTM	Roofing System Acceptability	
			Fully Adhered	Mechanically Attached
Thermapink 18	.75"	Refer to Product Data Sheet	N/A	√ (1)
Thermapink 25	1"	Refer to Product Data Sheet	N/A	√ (1)
Foamular 400	1"	Refer to Product Data Sheet	N/A	√ (1)
Dow Styrofoam Deckmate Plus	1"	Refer to Product Data Sheet	N/A	√ (1)
Design Restrictions				
-Local Codes must be consulted regarding the acceptance of expanded insulation directly over steel decks. When specified, minimum thickness shall be designated by the manufacturer. -Extruded polystyrene roof insulations cannot be installed directly over coal-tar pitch roof surfaces or existing PVC membranes. A separation layer of minimum 1/2" XFP HD, Recovery Board or Polyiso Insulation shall be used. -Refer to related products listed in Spec Supplement P-01-22 "Related Products" for other products which may be suitable for use. WeatherBond must be contacted for specific requirements.				
(1) WeatherBond PVC Membrane is not acceptable for this application.				
Notes: N/A = Not Acceptable √ = Acceptable				

2. Thermapink 18 or 25 Extruded Polystyrene
3. Foamular 400 Extruded Polystyrene
4. Dow Styrofoam Deckmate Plus Extruded Polystyrene

C. **Cover Boards / Slip Sheets**

Table E1 Cover Boards / Slip Sheets (see below for product descriptions)				
Insulations / Underlayment	Minimum Thickness	ASTM	Roofing System Acceptability	
			Fully Adhered	Mechanically Attached
XFP HD	.5"	C1289, Type II, Class 4 (109 psi)	√	√
XFP HD Plus	.5"	C1289, Type II, Class 4 (109 psi)	√	√
XP HD		C1289, Type II, Class 1, Grade 3	N/A	√
Securock Cover Board	.25"	Refer to Product Data Sheet	√	√
DensDeck StormX Prime	.625"	C1177	√	√ (1)
DensDeck Prime	.25"	C1177	√	√ (1)
DensDeck	.25"	C1177	N/A	√ (1)
R-Tech Fanfold Recovery Board	.5"	C578 Type (I, VIII, II. or IX)	N/A	√ (2)
HP Protection Mat	6 oz	Refer to Technical Data Bulletin	N/A	√
Design Restrictions				
-R-Tech Fanfold not recommended for direct use over Type B and F steel decks. -XFP HD not recommended for direct use over steel decks in lieu of thermal barrier. Fire testing standards yet to be established. -Securock Cover Board, Recovery Board, DensDeck StormX Prime, DensDeck Prime or DensDeck may not be used directly over New or Existing Lightweight Insulating Concrete Decks existing or Structural Concrete. - DensDeck, DensDeck Prime and DensDeck StormX Prime not recommended for use directly over existing roofing membrane -R-Tech Fanfold primarily for use in existing roof re-covers applications or directly over structural or lightweight insulating concrete.				
(1) Permitted for use on combustible decks with slopes greater than 2" per foot for compliance with external fire codes, refer to UL listings or contact WeatherBond.				
(2) Install Polymeric Side Up when installing WeatherBond PVC membrane.				
Notes: N/A = Not Acceptable √ = Acceptable				

2. **XFP HD** – a rigid insulation panel composed of a high-density (100 psi), closed-cell polyisocyanurate foam core laminated to coated-glass fiber-mat facer for use as a cover board or recover board. Available 1/2" thick 4' x 8' panel weight 11 lbs with an R-value of 2.5.
3. **XFP HD Plus** – A rigid insulation panel composed of a high-density (109 psi max), closed-cell polyisocyanurate foam core laminated to premium-performance coated-glass fiber-mat facer for use as a cover board or recover board. Available 1/2" thick 4' x 8' panel weight 11 lbs with an R-value of 2.5. Meets an FM 1-90 using only 8 fasteners per 4' x 8' board.
4. **XP HD** – a closed-cell polyisocyanurate foam core insulation board covered on both sides with glass-reinforced felt (GRF) facer meeting ASTM C 1289, Type II, Class 1, Grade 3. The product is available in 4' x 4' and 4' x 8' standard sizes with a thickness of one half inch.
5. **Securock Cover Board** – A uniform composition of fiber-reinforced with no facer for use as a cover board or a thermal barrier. Available in 1/4" to 5/8" thick and 4' x 4' or 4' x 8' size boards. Long uninterrupted runs (>200') may require slight gapping due to thermal expansion.
6. **DensDeck StormX Prime** –a reinforced gypsum cover board with an enhanced, moisture-resistant core and coated glass mat facers on the top and bottom side. The top surface is pre-primed and provides excellent bond strength for adhered membrane for use as a cover board. DensDeck StormX Prime is extremely durable and is approved for use in assemblies meeting FM's Very Severe Hail (VSH) Classification. Available in 5/8" thickness and 4' x 4' or 4' x 8' size boards.
7. **DensDeck Prime** –gypsum core that incorporates glass-mat facings on the top and bottom side. The top surface is pre-primed and provides excellent bond strength for fully adhered membrane for use as a cover board. Available in 1/4" to 5/8" and 4' x 4' or 4' x 8' size boards.
8. **DensDeck Cover Board** –gypsum core that incorporates glass-mat facings on the top and bottom side for use as a cover board. Available in 1/4" to 5/8" and 4' x 4' or 4' x 8' size boards.
9. **R-Tech FanFold Recover Board** – Closed-cell lightweight expanded polystyrene (EPS) with polymeric laminated faces which meets ASTM C 578 for use as a recover board. Polymeric facer compatible with PVC membrane, while metallic side used with EPDM. Available in thicknesses of 3/8" to 3/4" with coverage 4' x 50' (2 squares). 4' x 8' units are also available.
10. **HP Protection Mat** – A nominal 6-oz per square yard UV resistant polypropylene needle punched fabric used as an underlayment to the membrane. Available 15' x 30' roll (450 square foot) weighing 0.06 lbs per square foot.

2.03 Related Materials

- A. **WeatherBond TPO Flashing (for use with WeatherBond TPO Adhered, Mechanically Attached and WeatherBond PAS Fully Adhered Membrane Assemblies)**
 1. **WeatherBond TPO Flashing:** WeatherBond TPO **non-reinforced flashing** is available in rolls **12" and 24" wide by 50' long**. Flashing is used for inside/outside corners and field fabricated pipe flashings when the use of pre-molded or pre-fabricated accessories is not feasible. In addition, **45-mil by 6" wide by 100' long and 60-mil by 9" wide by 50' long and 80-mil by 9" wide by 50' long** WeatherBond TPO **reinforced membrane** is available for overlaying fasteners and fastening plates.
 2. **WeatherBond TPO Pressure-Sensitive Cover Strip:** A nominal 40-mil thick non-reinforced TPO membrane laminated to nominal 35-mil thick cured synthetic rubber pressure-sensitive adhesive used in conjunction with TPO Primer or Low VOC TPO Primer to strip in flat metal flanges (i.e., drip edges or rows of fasteners and plates). Available in rolls 6" wide by 100' long in colors of white, gray or tan.
 3. **APEEL Cover Tape:** A 6"-wide, 1,640' long roll of APEEL Protective Film used to protect areas of WeatherBond TPO membrane where APEEL Protective Film has been removed (around details) or was not factory applied (seams). APEEL Cover Tape allows contractors to keep 100 percent of the TPO surface clean during installation and is applied using the APEEL Cover Tape Applicator.
 4. **WeatherBond TPO Pressure-Sensitive RUSS:** A nominal 6" and 10" wide, 45-mil thick reinforced TPO membrane with nominal 3" wide 35-mil thick cured synthetic rubber pressure-sensitive adhesive laminated along one end on 6" wide RUSS and along both ends on 10" wide RUSS. Used in conjunction with TPO Primer or Low VOC TPO Primer. 6" wide RUSS is used as a base membrane securement along walls, curbs, etc.; 10" wide RUSS is used to form perimeter sheets on Mechanically Attached Systems.
 5. **WeatherBond TPO T-Joint Covers:** A 60-mil thick injection molded TPO flashing formed into a 4.5" diameter

circle used to seal step-offs at splice intersections. Installation is mandatory on all 60-, 72-, and 80-mil TPO systems and on 45-mil systems where step-offs have not been properly sealed. Packaged in boxes of 100. Available in white, tan or gray.

6. **Yellow Pressure-Sensitive (PS) Warning Strip:** A nominal 30-mil-thick non-reinforced TPO flashing laminated to a nominal 30-mil-thick, fully cured synthetic rubber Pressure-Sensitive adhesive and is available in 6" wide by 100' long rolls. Yellow Pressure-Sensitive Warning Strip can be applied to EPDM, TPO or Hypalon roofing systems to provide a visual warning of an impending hazard (i.e. roof edge, deep drain sump, skylight).
7. **WeatherBond TPO Rib Profile:** Used to obtain the appearance of standing seam metal roofing with the performance of a TPO single-ply membrane. TPO Rib Profile measures 1-1/4" tall and 1-3/4" wide, including the welding flanges, while the vertical profile is a substantial 3/8" thick. The profile has a continuous 1/8" diameter alignment hole, for use with fiberglass connecting pins, as well as a 1/8" fiberglass reinforcing cord for added strength. TPO Rib Profile is available in white, gray and tan, as well as Special Colors (Medium Bronze, Rock Brown, terra Cotta, Slate Gray and Patina Green) in 10' lengths and packaged 20 per carton.
8. **Pre-Molded Accessories:**
 - a) **Inside Corners:** A pre-molded corner flashing for inside corners. Available in white, gray or tan; 60-mil thick.
 - b) **Outside Corners:** A one-piece injection molded corner flashing used for flashing outside corners. Available in white, gray or tan; 60-mil thick.
 - c) **TPO Curb Wrap Corners:** Fabricated flashings are made of 60-mil thick reinforced WeatherBond PRO TPO membrane designed to reduce installation time to flash a curb when compared to conventional methods. Each corner is fabricated with a 6" wide base flange and a 12" overall height. Six sizes are available to fit curbs up to 6' by 6' in size. One curb requires 4 corners for a complete installation. TPO Curb Corners are packaged in boxes containing twelve. Corners. Custom sizes are available as a special order product requiring lead time.
 - d) **TPO Universal Corners:** a pre-molded flashing for use in a variety of corner details, including inside and outside corners. Available in white, gray and tan and are 60-mil thick.
 - e) **Pipe Flashings:** A pre-molded white, gray or tan pipe flashing used for pipe penetrations. Available for 3/4" –8" diameter pipes with clamping rings included.
 - f) **Split Pipe Seals:** A prefabricated flashing consisting of 60-mil thick reinforced WeatherBond TPO Membrane for pipes 1" – 6" in diameter. A split (cut) and overlapped tab are incorporated to allow the pipe seal to be opened and wrapped around the pipe when it is not possible to pull a standard pipe flashing over a round penetration. Custom sizes are available as a special order product requiring lead time.
 - g) **TPO Square Tubing Wraps:** Fabricated flashings made of 60-mil thick reinforced WeatherBond TPO membrane for square tubing. A split (cut) and overlap tab are incorporated into these parts to allow the seals to be opened and wrapped around a square penetration. Available for 3", 4", 5" and 6" square tubing
 - h) **Molded TPO Sealant Pockets:** A pre-fabricated, interlocking, 2-piece, injection molded, flexible pocket with a rigid polypropylene vertical wall and pre-formed deck flanges. Pockets can be adjusted from 11.5" to 7.5" in length by 6" in width by following the cutting lines molded into the pocket. Used in conjunction with White One-Part Pourable Sealer for waterproofing pipe clusters or other odd shaped penetrations. Available in white, gray or tan
 - i) **Pre-fabricated Sealant Pockets:** A two-piece, pre-fabricated sealant pocket that utilizes reinforced 60-mil TPO membrane and coated metal to form a rigid, oversized sealant pocket with a weldable horizontal deck flange. Available in 12" (total volume of 1.87 gallons). Packaged 2 per carton and available in white only. Refer to the applicable Technical Data Bulletin for dimensions and installation instructions. Custom sizes are available as special order products.
 - j) **Sealant Pocket Extension Legs:** Designed for use with the TPO Molded Sealant Pocket and the Pre-Fabricated Sealant Pocket to extend the length in increments of 10". Fabricated from 45-mil thick reinforced TPO membrane and TPO coated metal. Can be used full length, cut to size for customized lengths or welded to each other for extra-long applications. Packaged 10 legs per carton and available in white only.

B. Primers, Adhesives, Sealants and Cleaners

Refer to Technical Data Bulletins for material coverage rates and proper usage. Prior to the use of any of the products

listed below, consult the Safety Data Sheets for applicable cautions and warnings.

1. WeatherBond TPO Products

- a) **WeatherBond TPO Bonding Adhesive:** A high-strength, synthetic rubber adhesive used for bonding WeatherBond TPO membrane to various surfaces. The adhesive is applied to both the membrane and the substrate at a coverage rate of approximately 60 square feet per gallon per finished surface (includes coverage on both surfaces).
- b) **Low VOC Bonding Adhesive for TPO:** This product meets the <250 gpl VOC (volatile organic compound) content requirements of the OTC Model Rule for Single-Ply Roofing Adhesives. A high strength, solvent-based contact adhesive that allows bonding of TPO membrane to various porous and non-porous substrates. Apply at a rate of 60 ft² per gallon finished surface. Available in 5 gallon pails. **This product does not comply with certain counties in the State of California which have additional restrictions on solvents.**
- c) **Low VOC Bonding Adhesive 1168:** This product meets the <250 gpl VOC (volatile organic compound) content requirements of the OTC Model Rule for Single Ply Roofing Adhesives. A high strength, solvent-based contact adhesive that allows bonding of TPO membrane to various porous and non-porous substrates. Apply at a rate of 60 ft² per gallon finished surface. Available in 5-gallon cans. **This product complies with all counties in the State of California which have additional restrictions on solvents.**
- d) **Aqua Base 120 Bonding Adhesive:** A semi pressure-sensitive, water based adhesive used as a two-sided contact adhesive. Coverage rate is 120 square feet per gallon finished surface (applied to membrane and substrate). Refer to Spec Supplement G-09-22 "Aqua Base 120 Bonding Adhesive" for other considerations.
- e) **CAV-GRIP III Low-VOC Aerosol Contact Adhesive/Primer:** a low-VOC, spray-applied aerosol contact adhesive and primer used for a variety of applications: adhering standard WeatherBond TPO and WeatherBond EPDM membranes to horizontal and vertical surfaces, adhering WeatherBond Fleece membranes to vertical surfaces, as a primer for VapAir Seal 725TR, and as an unexposed asphalt primer for Flexible DASH for insulation attachment.
- f) **Cut-Edge Sealant:** A clear colored sealant used to seal cut edges of reinforced WeatherBond PRO TPO membrane. A coverage rate of approximately 225 - 275 linear feet per squeeze bottle can be achieved when a 1/8" diameter bead is applied.
- g) **Water Cut-Off Mastic:** Used as a mastic to prevent moisture migration at drains, compression terminations and beneath conventional metal edging (at a coverage rate of approximately 10' per tube or 100' per gallon).
- h) **Universal Single-Ply Sealant:** A 100% solids, solvent free, voc free, one part polyether sealant that provides a weather tight seal to a variety of building materials. It is white or grey in color and is used for general caulking such as above termination bars and metal counter flashings and at scuppers.
- i) **White One-Part Pourable Sealer:** A one-part, moisture curing, elastomeric polyether sealant used to fill Molded Pourable Sealant Pockets. Packaged in 4, 2-liter foil pouches inside a reusable plastic bucket. 1 pouch will fill 122 cubic inches of volume within a sealant pocket.
- j) **Weathered Membrane Cleaner:** Used to prepare membrane for heat welding that has been exposed to the elements or to remove general construction dirt at an approximate coverage rate of 400 square feet per gallon (one surface).
- k) **TPO Primer:** A solvent-based primer used to prepare the surface of WeatherBond PRO TPO Membrane prior to application of Pressure-Sensitive Coverstrip and TPO Pressure-Sensitive RUSS.
- l) **TPO Low VOC Primer:** A solvent-based, low solids primer used to prepare the surface of WeatherBond TPO Membrane prior to application of Pressure-Sensitive Coverstrip and TPO Pressure-Sensitive RUSS. This low VOC product is ideal for use in states where environmental issues are a concern.

2.04 Fastening Components

A. Securement Strips (RUSS)

1. **WeatherBond TPO Pressure-Sensitive RUSS (Reinforced Securement Strip):** A 6" or 10" wide, nominal 45-mil thick reinforced TPO membrane STRIP with a nominal 35-mil thick cured TPO splice tape adhesive laminated along one or both edges. (3" wide Peel & Stick P&S Seam Tape laminated along one edge for the 6" wide RUSS and along both edges for the 10" wide RUSS.)
 - a) 6" wide Pressure-Sensitive RUSS is used horizontally or vertically at the base of walls, curbs, etc., in conjunction with Seam Fastening Plates below the WeatherBond TPO deck membrane for additional membrane securement. Available in rolls 100' long, 2 per carton.
 - b) 10" wide PS RUSS is utilized for perimeter membrane securement along the center of field sheets to form perimeter membranes. Available in rolls 100' long, 1 per carton.

B. Fasteners

The following Table illustrates criteria for fastening of WeatherBond Insulation with the referenced roof deck and includes minimum penetration requirements and pilot hole criteria.

Insulation Fastening Criteria

Deck Type	WeatherBond Fasteners (1)	Min. Penetration	Pilot Hole Depth	Pilot Hole Diameter
Steel or Lightweight Insulating Concrete over Steel	ASAP or InsulTite	3/4"	N/A	N/A
Structural Concrete, rated 3,000 psi or greater	CD-10	1"	Note (2)	7/32"
	MP 14-10	1"	Note (2)	3/16"
Wood Plank, min. 15/32" thick Plywood or min. 7/16" OSB	HPW, ASAP or InsulTite	Min. 1" (3)	N/A	N/A
Cementitious Wood Fiber	Polymer Gyptec or Lite-Deck Fasteners	1-1/2"	Note (4)	N/A
Gypsum	Polymer Gyptec or Lite-Deck Fasteners	1-1/2"	Note (2)	7/16", 1/2" or 9/16" (5)

Notes: N/A = Not Applicable

(1) For Fully Adhered Systems, only 3" diameter insulation fastening plates can be used for insulation attachment.

(2) The pilot hole must be predrilled to a sufficient depth to prevent contact between the fastener point and any accumulated dust in the predrilled hole. This will help prevent bottoming out of the fastener during installation.

(3) For wood planks only, fastener penetration shall not exceed 1-1/2".

(4) Most cementitious wood fiber decks do not require pre-drilling; however, WeatherBond should be contacted prior to installation for verification of specific types that may require a pilot hole to be predrilled.

(5) Pilot hole size may be varied to maximize pullout resistance.

All Fasteners listed below can be used with WeatherBond TPO Roofing Systems. Refer to the applicable specification for specific requirements.

1. **HPWX Fastener:** A heavy duty #15 threaded fastener with a #3 Phillips drive used with WeatherBond's HPWX Fastening Plate to secure Mechanically Attached Roofing Systems. It is used on minimum 22 gauge steel decks or minimum 15/32" CDX plywood decks. It is also designed to offer an optimum combination of driving performance, back-out and corrosion resistance with excellent pullout performance.
2. **HPW-XL Fastener:** An oversized diameter #22(.315") steel, threaded fastener used in conjunction with HPW-XL Plates for membrane securement into minimum 22 gauge steel or wood decks on Mechanically Attached Roofing Systems.
3. **HPW Fastener:** A threaded E-coat square head fastener **for insulation attachment only**. Used into steel, wood plank, minimum 15/32" thick plywood or minimum 7/16" thick oriented strand board (OSB).
4. **Pre-Assembled InsulTite ASAP Fastener:** WeatherBond's InsulTite Fastener pre-assembled with a 3" diameter plastic plate used for **insulation attachment only** on Fully Adhered and Mechanically Attached Roofing Systems. Installed using Olympic Fasteners' Fastening Tool.
5. **InsulTite Fastener:** A threaded Phillips drive fastener used with WeatherBond Insulation Plates for **insulation attachment** to steel or wood decks.
6. **CD-10 Fastener:** A hammer-driven, non-threaded E-Coat fastener for use with structural concrete decks rated 3,000 psi or greater.
7. **MP 14-10 Concrete Fastener:** A #14 threaded fastener with a #3 Phillips drive used for minimum 3,000 psi concrete decks.
8. **Polymer Gyptec Fastener:** A glass-filled nylon auger fastener designed for securing insulation and/or membrane to specialty decks such as cement wood fiber or gypsum.
9. **Lite-Deck Fastener:** A deep, coarse threaded fastener used to secure insulation to gypsum and cementitious wood fiber decks in conjunction with Lite-Deck Plates.

C. Fastening Plates

1. **HPWX Plate:** A 2-3/8" diameter metal barbed fastening plate used with WeatherBond HPWX CD-10 or MP 14-10 Fasteners for membrane or insulation securement. This plate can be used for membrane or insulation securement on Mechanically Attached Roofing Systems.
2. **HPW-XL Plate:** A 2-3/8" diameter metal barbed fastening plate with an oversized hole for use with WeatherBond HPW-XL Fasteners for membrane securement on Mechanically Attached Roofing Systems.
3. **Seam Fastening Plate:** A 2" diameter metal plate used for insulation attachment on Mechanically Attached Systems or membrane securement at angle changes on Fully Adhered Systems in conjunction with the appropriate WeatherBond Fastener.
4. **Insulation Fastening Plate:** A nominal 3-inch metal plate used for insulation attachment in conjunction with the appropriate WeatherBond Fastener.

2.05 Insulation Securement Adhesive

1. **Flexible DASH Adhesive:** A two-component (Part A and B), low-rise polyurethane adhesive designed for bonding Fleece membrane and/or insulation to various substrates. Flexible DASH Adhesive is packaged in 50- and 15-gallon drums, as well as, 5-gallon Jug and Dual Cartridges that can be applied in full spray or extrusion, depending on dispensing type.
2. **Flexible DASH Dual Tank:** A two component (Part A and B), extrusion applied, low rise adhesive for bonding insulation to various surfaces. DASH Dual Tanks utilize an HFO blowing agent. HFO (hydrofluoroolefin) blowing agents are widely recognized as the next-generation environmentally friendly blowing agent, replacing their HFC (hydrofluorocarbon) predecessor. When extruded at 12" on center the coverage rate is 3,500 to 3,700 sq.ft. per set of Dual Tanks.
3. **Flexible DASH Dual Cartridge and 5-gallon Jug Adhesive:** A two component (Part A and B), extrusion applied, low rise adhesive for bonding insulation to various surfaces. When extruded at 12" on center the coverage rate is 400-600 sq.ft. per carton of Dual Cartridges or 2,000-2,500 sq.ft. per set of 5-gallon Jug Adhesive.
4. **OlyBond 500 BA** – A two-component, polyurethane, low-rise expanding adhesive used to bond insulation to various substrates. Packaged in 5-gallon pails of Part A and Part B formulations that are applied using a mechanical dispenser system. Applied in 1/2" to 3/4" beads or ribbons at the rate of 1 gallon per 150-250 square feet for 12" o.c. bead spacing. Perimeter bead spacing patterns and acceptable insulation and deck types are listed in the applicable Technical Data Bulletin.
5. **OlyBond Spot Shot** - A two-component, polyurethane construction grade, low-rising expanding adhesive designed for bonding insulation to various substrates. Applied in 1/2" to 3/4" beads or ribbons using a portable 1:1 applicator (oversized, dual-cartridge caulking gun). Refer to the Technical Data Bulletin for bead spacing with reference to building height.

2.06 Vapor / Air Barrier

1. General

If insulation is to be fully adhered to the vapor retarder with Flexible DASH Adhesive, the vapor retarder must be compatible and shall be fully adhered to the substrate. Available products include WeatherBond supplied "peel and stick" rubberized asphalt membrane with compatible film coating (725 Air and Vapor Barrier), and spray or roller applied butyl coatings. Installation requirements for 725 Air and Vapor Barrier are identified in Spec Supplement G-07-22 "Application Procedures for 725 TR Air and Vapor Barrier".

2. **VapAir Seal 725TR Air and Vapor Barrier** - A 40-mil thick composite consisting of 35-mil self-adhering rubberized asphalt membrane laminated to an 5-mil UV resistant poly film with an anti-skid surface which is fully compatible with Flexible DASH Adhesive. 725TR can also function as a temporary roof for up to 120 days. Available in rolls 39" wide by 100' long (325 square feet).
3. **VapAir Seal MD Air and Vapor Barrier** – a reinforced composite aluminum foil with self-adhesive SBS backing and removable poly release film. Used for direct application over metal decks. Used for direct application over metal decks. Available in rolls 42.5" wide by 131.23" long (460 square feet).
4. **CCW-702 Primer and 702LV Primer (Low-VOC)** - A single component, solvent based, high-tack primer used to provide maximum adhesion between 725TR Air and Vapor Barrier and an approved substrate. Applied by spray or long nap roller with a coverage rating ranging from approximately 300 to 350 square feet per gallon on smooth finishes (i.e., concrete) to 75 square feet per gallon on porous surfaces (i.e., Dens-Deck Prime gypsum

board). Available in 5-gallon containers. CCW-702LV Primer contains less than 250g/L VOCs and meets South Coast Air Quality Management District (SCAQMD) and Leadership in Energy and Environmental Design (LEED) Requirements for Volatile Organic Compounds.

5. **CAV-GRIP III Low-VOC Aerosol Contact Adhesive/Primer:** a low-VOC, methylene chloride-free adhesive that can be used for a variety of applications including: enhancing the bond between VapAir Seal 725TR and various substrates. Coverage rate is approximately 2,000-2,500 sq. ft. per 40 lb cylinder and 4,000-5,000 sq. ft. per 85 lb cylinder as a primer, in a single-sided application.

2.07 Metal Accessories, Edgings, Coping and Terminations

A. General

Products listed below can be used with any of the available WeatherBond Roofing Systems. Refer to the applicable WeatherBond details and installation instruction manuals for specific installation criteria.

B. Products

1. **WeatherBond TPO Coated Metal:** A 24 gauge, galvanized steel sheet coated with a layer of 40-mil non-reinforced WeatherBond TPO Flashing. The sheet is cut to the appropriate width and used to fabricate metal drip edges or other roof perimeter edging profiles. WeatherBond TPO Membrane may be heat welded directly to the coated metal. Coated metal is available in sheets 4' x 10' and comes packaged 25 sheets per pallet (also available packaged 10 sheets per pallet on a direct ship basis). Available in white, gray or tan. Also available in TPO Special Colors (Medium Bronze, Rock Brown, Terra Cotta, Slate Gray and Patina Green) and comes packaged 5 sheets per pallet on a direct ship basis.
4. **Termination Bar:** A 1" wide and 98-mil thick extruded aluminum bar pre-punched 6" on center which incorporates a sealant ledge to support Lap Sealant and provide increased stability for membrane terminations.
5. **Term Bar Fascia:** A 1.75" wide formed aluminum termination bar with pre-slotted fastening holes for ease of locating and installing. The decorative cover is available in 0.040" aluminum or 24-gauge galvanized steel. Term Bar Fascia is manufactured in 12' lengths for fewer joints/seams, fewer sections to handle and faster installation.
6. Refer to Spec Supplement P-01-22 "Related Products" for other edgings and coping materials.

2.08 Roof Walkways

Walkways are to be specified at all traffic concentration points (i.e., roof hatches, access doors, rooftop ladders, etc.), and if regular maintenance (once a month or more) is necessary to service rooftop equipment.

1. Walkway Types

- a) **WeatherBond TPO Heat Weldable Walkway Rolls:** Designed to protect WeatherBond TPO membrane in those areas exposed to repetitive foot traffic or other hazards. Walkway material may be heat welded to WeatherBond TPO membrane using an automated heat welder or hand held heat welder. The diamond plate tread pattern offers superior slip resistance. The walk edges are trimmed in safety yellow to better define the designated traffic flow. Walkway Rolls are 34" wide by 50' long and are nominal 180 mils thick. Available in white, tan or gray with safety yellow welding tabs along both edges.

NOTE: As an option, walkway rolls may be fully adhered to the membrane surface with P&S Seam Tape/TPO Primer.

- c) **TPO Crossgrip Walkway Rolls:** Manufactured from TPO and may be used in lieu of standard TPO Walkway Rolls when a walkway is to be loose-laid and not secured to the membrane. Loose-laid Crossgrip TPO Walkway Rolls are effective for winds up to 55 mph. Rolls are 36" wide by 33' long, available in white, gray and yellow.
- d) **Interlocking Rubber Pavers, 24" X 24" X 2"**, weighing approximately 6 pounds per square foot, may be specified loose-laid directly over the membrane.
- e) **Smooth Concrete Pavers**, when specified in conjunction with insulation that is mechanically attached, must be loose laid over a slip sheet of membrane or 2 layers of HP Protective Mat. When insulation is attached

with Flexible DASH Adhesive, concrete pavers may be placed over one layer of WeatherBond Protective Mat. Pavers cannot weigh more than 80 pounds per paper for ease of removal.

2.09 Other WeatherBond Accessories

Refer to Spec Supplement P-01-22 "Related Products" for additional accessories.

Part III – Execution

Prior to commencing with the installation of any of the Thermoplastic Membrane Systems refer to Paragraph 1.05 "Tables" for applicable components and proper securement method.

3.01 General

- A. Safety Data Sheets (SDS) must be on location at all times during transportation, storage and application of materials. The contractor shall follow all safety regulations as recommended by OSHA and other agencies having jurisdiction.
- B. Subject to project conditions, it is recommended to begin the application of this roofing system at the highest point of the project area and work to the lowest point to prevent water infiltration. This will include completion of all flashings, terminations and daily seals.
- C. A proper substrate shall be provided by the building owner. The structure shall be sufficient to withstand normal construction loads and live loads.

3.02 Roof Deck /Substrate Criteria

- A. Proper decking shall be provided by the building owner. The building owner or its designated representative must ensure that the building structure is investigated by a registered engineer to assure its ability to withstand the total weight of the specified roofing system, as well as construction loads and live loads, in accordance with all applicable codes. The specifier must also designate the maximum allowable weight and location for material loading and storage on the roof.
- B. Withdrawal resistance tests are strongly suggested to determine the suitability of a roof deck. Refer to Design Reference DR-06-22 "Withdrawal Resistance Criteria" for proper procedures for conducting pullout tests.
- C. Defects in the substrate must be reported and documented to the specifier, general contractor and building owner for assessment. The WeatherBond Contractor shall not proceed with installation unless defects are corrected.
- D. On structural concrete decks, when a vapor retarder is not used, gaps in the deck along the perimeter and around penetrations must be sealed along with vertical joints between tilt-up panels, if present, to prevent infiltration of hot humid air and possible moisture contamination resulting from condensation. This is specifically important when adhesive is used to attach the roof insulation. (Migrating warm air through gaps left unsealed can result in condensation and weakening of the insulation bottom facer leading to possible board dislodgement.)
- E. **For all projects** (new or retrofit), the substrate must be relatively even without noticeable high spots or depressions. Accumulated water, ice or snow must be removed to prevent the absorption of moisture in the new roofing components and roofing system.
- F. Prior to the placement of membrane underlayment, clear the substrate of debris and foreign material that may be harmful to the roofing system. Gaps greater than 1/4" must be filled with an appropriate material.
- G. For direct application over an acceptable roof deck/substrate or when HP Protective Mat is specified and approved by WeatherBond as the membrane underlayment in accordance with the Roof Deck and Substrate Criteria Table, the substrate must be smooth, steel trowel finished (structural concrete), free of debris, protrusions, sharp edges and loose and foreign material. Cracks or voids in the substrate, greater than 1/4", must be filled with an appropriate material.
- H. The following chart identifies the acceptable roof decks/substrates and the minimum underlayment requirements, Tables in Paragraph 1.05 for specific acceptable underlayment types:

TPO Membrane		Acceptable Roof Deck/Substrate
Fully Adhered	Mechanically Attached	NEW CONSTRUCTION
Insulation	Insulation	Steel (min. 22 gauge)(1)(2), Wood Plank (3/4" min.), or Fibrous Cement
Direct Application	Insulation	Structural Concrete (min. 3000 psi) or Gypsum
Direct Application(5)	Direct Application(5)	Plywood (min. 15/32" thick) or Oriented Strand Board (min. 7/16" thick)
Direct Application (5)(10)	Direct Application(5)	Lightweight Insulating Concrete
Fully Adhered	Mechanically Attached	RETROFIT / NO TEAR-OFF
Direct Application (9)(11)	Direct Application (9)(11)	Existing Smooth Surface BUR (8) or Mineral Surface Cap Sheet
Insulation	Insulation	Gravel Surfaced BUR (3)(4) or Coal Tar Pitch (3)(4)
Direct Application (7)(9)	Direct Application (7)(9)	Modified Bitumen (11)
Insulation	Direct Application (6)	Existing Single-Ply (11)
Complete Tear-off Required	Complete Tear-off Required	Sprayed-in-place Urethane
Fully Adhered	Mechanically Attached	RETROFIT / TEAR-OFF
Insulation	Insulation	Existing roof material removed (regardless of deck type)

Notes:

(1) Local codes must be consulted regarding thermal barrier requirements.

(8) Existing Type III or IV smooth asphalt BUR Only.

- I. **On retrofit - recover projects**, cut and remove wet insulation, as identified by the specifier, and fill all voids with new insulation of type specified so it is relatively flush (+/- 1/4") with the existing surface.

1. Entrapment of water between the old and new membrane can damage and deteriorate new insulation/underlayment between the two membranes. **If a vapor retarder or air barrier is not specified**, WeatherBond recommends the existing membrane be perforated to avoid potential moisture accumulation and to allow the detection of moisture to enable the building owner to take corrective action. This can be accomplished by drilling approximately 3/4" diameter holes every 100 square feet in the existing built-up roof or single-ply membrane (excluding non-reinforced PVC membrane).
2. If total removal of existing PVC membrane is not specified, existing non-reinforced membrane may be cut into maximum 10' x 10' sections, when the new insulation or membrane underlayment is to be mechanically attached.
3. Regardless of the type of membrane or assembly selected, any loose flashings at the perimeter, roof drains and roof penetrations must be removed.
4. When installing this roofing system over an existing **gravel surfaced built-up roof, loose gravel must be removed**. Power brooming is recommended by WeatherBond to remove the loose gravel, which may trap moisture. Any uneven areas of the substrate must be leveled to prevent insulation from bridging.
5. On retrofit projects, all existing phenolic insulation must be removed.
6. Refer to table above for other Recover/Retro-fit considerations.

J. **Vapor Retarder Installation**

Refer to Spec Supplement G-07-11 "Application Procedures for 725TR Air and Vapor Barrier". Follow the respective vapor retarder manufacturer's recommended installation procedures and the specifier's instructions for the installation of the product specified. When insulation is to be set in adhesive, verify compatibility with WeatherBond when Vapor Retarder by others is specified.

K. **Wood Nailers**

1. Install wood nailers in locations that have been designated by the specifier and as approved by WeatherBond. Refer to Design Reference DR-08-11 "Wood Nailers and Securement Criteria" for Wood Nailer Criteria.

3.03 Insulation/Underlayment

A. General

1. Roof insulation thickness must be determined by the thermal value required for each project and may be subject to code approval limitations. On projects where a vapor retarder is used, the specifier must calculate insulation thickness to ensure the temperature at the vapor retarder will not fall below the dew point.
2. New construction projects in cold climate regions, the use of vapor retarders or air barriers is strongly recommended to protect insulation from moisture generated during construction.
3. Multiple layers of insulation are recommended with all joints staggered between layers.
4. Do not install more insulation/underlayment than can be covered by membrane in the same day.
5. All insulation boards must be butted together with no gaps greater than 1/4". Gaps greater than 1/4" are not acceptable.
6. Restrictions:
 - a) WeatherBond Roofing Systems cannot be specified in conjunction with Phenolic Insulation.
 - b) Fiberglass insulation cannot be specified even if overlaid with additional insulation or membrane underlayment.

3.04 Insulation Attachment

A. General

1. Prior to proceeding with insulation securement refer to Tables, Paragraph 1.05, for attachment method and appropriate fastening density.

B. Fully Adhered Roofing Systems

1. **Mechanical Attachment**, insulation fastening density will vary based on insulation type and thickness. Tables in Paragraph 1.05 should be referenced for fastening density and the appropriate WeatherBond detail may be consulted to identify acceptable fastening pattern.
 - a) For code compliance, increased fastening density may be required depending upon project wind speed and wind uplift requirement. Refer to Design Reference DR-05-22 "Insulation Fastening Patterns" for fastening pattern reference.
 - b) When insulation securement is to comply with Factory Mutual (FM) approvals, follow the requirements of the specifier concerning additional securement at the roof perimeter and corners. Also refer to Design Reference DR-05-22 "Insulation Fastening Patterns" for various fastening patterns.
 - c) On Reroof/No Tear off projects with a maximum roof height of 40', any WeatherBond Insulation (i.e., 1/2" XFP HD, Recovery Board, Polyisocyanurate less than 1-1/2" thick) may be secured at the minimum rate of 11 Fasteners per 4' x 8' board (5 Fasteners per 4' x 4' board).
 - d) Oriented strand board (OSB) when specified as the membrane underlayment, must be mechanically attached to the deck at the rate 17 fasteners for 4 x 8 board in accordance with WeatherBond Details. If OSB is to be used in conjunction with WeatherBond urethane based adhesive, an OSB/Polyisocyanurate composite board is recommended. When positioning OSB it shall not be butted, allow 1/8" gaps between boards to prevent cupping.
2. **Adhesive attachment**, WeatherBond Urethane Adhesive (Flexible DASH or Olybond) may be used. When bead adhesive is specified bead spacing will vary, refer to Tables, Paragraph 1.05 and appropriate WeatherBond Details.

CAUTION: Apply adhesive bead so that the distance from the edge of the board does not exceed half the

bead spacing (i.e. within 6" of bead spacing of 12" O.C.).

CAUTION: Do not apply urethane adhesives directly to un-weathered asphalt, (new or residual).

CAUTION: Especially in cold regions on tear-off projects or new construction gaps between horizontal and vertical surfaces of the roof area as well as gaps around penetrations must be sealed to prevent interior warm air from infiltrating and condensing within the roofing assembly. Condensing moisture could weaken bottom insulation facer and eventually result in dislodgement or loose boards when adhesive is used.

- a) On FM Global insured projects, consult FM Global's local representative concerning the use of adhesive to attach insulation to steel decks.
- b) Check to ensure the substrate is clean, free of debris, other contaminants, and dry. Adhesive cannot be applied to a wet or a damp surface.
- c) Apply Adhesive over the dry substrate area at the coverage rates indicated in Spec Supplement G-02-22 "DASH Adhesive Application/Coverage Rates".
- d) Allow the adhesive to rise up approximately 1/8" and develop strings prior to setting insulation boards into adhesive.

NOTE: String-time is measured by touching the adhesive with a splice wipe and looking for development of "strings" of adhesive as you pull the splice wipe out of the adhesive. With Flexible DASH Adhesive, string time is generally around 1-1/2 – 2 minutes after application at room temperature.

- e) **Walk the boards into the adhesive and roll using the 30" wide, 100 – 150 pound weighted segmented steel roller** to ensure full embedment. Optimal set up time should be approximately 5 to 7 minutes.

CAUTION: Walking on the boards immediately after placement in adhesive can cause slippage/movement until the adhesive has started to set up.

On roofs with a slope greater than 1/2" in 12", begin adhering insulation at the low point and work upward to avoid slippage.

A person should be designated to walk/roll-in all boards and trim/slit or apply weight as needed to ensure adequate securement.

- f) Refer to Spec Supplement G-02-22 "Adhesive Application/Coverage Rate" for application procedures and coverage rates.

3. **Alternate attachment method**, the specifier may select an alternate insulation attachment that incorporates a solid mopping of the insulation with hot asphalt (ASTM D312, Type III or IV).

- a) Extruded or Expanded Polystyrene insulation are not acceptable when this alternate attachment method is specified.
- b) The existing gravel surfaced built-up roof must be scraped to remove all loose gravel. Large blisters that may prevent continuous embedment of insulation must be repaired. The surface of the substrate must also be dry and clear of foreign material.
- c) On coal tar pitch, when deemed compatible by the specifier, minimum 1.5" Polyisocyanurate is the required membrane underlayment when using darker heat weldable membranes (tan or gray). If WeatherBond TPO white membrane is used, minimum 1" thick Polyisocyanurate is required.
- d) For successful attachment, proper asphalt temperatures must be maintained and the specifier's requirements concerning the installation of a base sheet (where required) and quantity of hot asphalt must be followed.
- e) The maximum insulation board size shall not exceed 4' X 4'. Trim insulation boards around crickets and saddles to ensure continuous embedment.
- f) Care must be exercised to prevent contamination of the top surface of the insulation. Asphalt oozing through insulation joints must be wiped from the surface. Contact with fresh asphalt can result in discoloration of the WeatherBond TPO.
- g) A grid shall be installed subdividing the roof in individual sections of 2400 square feet. Required for wind

speed coverage up to 55mph.

- h) The wood nailers are installed relatively flush with the insulation surface and the membrane is to be fastened with seam fastening plates and WeatherBond HPW or HPWX Fasteners on 12" o.c. For wood nailer installation, refer to Design Reference DR-08-22 "Wood Nailers and Securement Criteria".

C. Mechanically Attached Roofing Systems

1. **WeatherBond Fasteners and Fastening Plates are required for insulation securement.** Refer to Insulation Fastening Criteria Table in Paragraph 2.05 for appropriate fastener and deck penetration. The fastener can be used with either 2-3/8" diameter HPWX/HPW-XL Plates OR 3" diameter Insulation Fastening plate.
2. **Any WeatherBond approved insulation or cover board** shall be mechanically attached to the roof deck at the minimum rate of **1 fastener and plate per every 8 square feet** (4 fasteners in a 4 x 8 board).

CAUTION: WeatherBond Polyisocyanurate Insulation with a thickness less than 1.5" installed over an existing roofing membrane without a tear-off must be mechanically attached to the roof deck with a minimum of **1 fastener and plate for every 4 square feet** or less of insulation.

3. Use of DensDeck, DensDeck Prime and DensDeck StormX Prime should be limited to assemblies with slopes greater than 2" per foot to ensure compliance with external fire codes.

3.05 Membrane Placement and Securement

A. General

1. **Ensure** that water does not flow beneath any completed sections of the membrane system by completing all flashings, terminations and daily seals by the end of each workday.
2. **Sweep** all loose debris from the substrate.
3. If aesthetics are of concern, protection should be specified to avoid discoloration of the white membrane surface resulting from adhesive residue or excess foot traffic.
4. In addition to the primary membrane securement (Bonding for Fully Adhered and Fastening for Mechanically Attached Assemblies), additional membrane securement is required at the perimeter of each roof level, roof section, curb, skylight, interior wall, penthouse, etc., at any inside angle change where slope or combined slopes exceed 2" in one horizontal foot, and at other penetrations in accordance with the applicable WeatherBond details. Refer to Paragraph F for additional membrane securement.

B. Membrane Placement

Maximum 12' wide WeatherBond TPO membrane is fully adhered or mechanically attached to an approved insulation or substrate.

1. **Position** WeatherBond TPO membrane over the acceptable substrate. For a mechanically attached assembly ensure the proper number of perimeter sheets are positioned along the perimeter of the roof as outlined in Paragraph 1.05 "Tables".
2. **Position** field sheets perpendicular to the steel deck flutes in Mechanically Attached Applications.
3. **Place** adjoining membrane sheets in the same manner, overlapping edges appropriately to provide for the minimum overlap width. It is recommended all overlaps be shingled to avoid bucking of water.

C. Membrane Securement / Bonding - Fully Adhered Roofing System

1. **Adhere** WeatherBond TPO membrane to an acceptable substrate with WeatherBond Bonding Adhesive. CAV-GRIP III Low-VOC aerosol adhesive may be utilized with WeatherBond TPO membranes. Comply with Labels, Safety Data Sheet (SDS) and Technical Data Bulletins for installation procedures and use. Adhesive must be applied to both the membrane and the surface to which it is being bonded.
2. On projects at high altitudes (6,000' and above), rapid flash off (drying) of Bonding Adhesive and Primers will occur due to low atmospheric pressure.
3. **Fold** membrane sheet back so half the underside is exposed. Sheet fold should be smooth without wrinkles or buckles.

4. **Stir** Bonding Adhesive thoroughly scraping the sides and the bottom of the can (minimum 5 minutes stirring is recommended). Bonding surfaces must be dry and clean.
5. **Apply** Bonding Adhesive to the exposed underside of the membrane and the corresponding substrate area. Do not apply Bonding Adhesive along the splice edge of the membrane to be heat welded over adjoining sheet.

When using **WeatherBond TPO Bonding Adhesive**, a coverage rate of approximately 120 square feet per gallon per one surface (membrane or substrate) or approximately 60 square feet per gallon per finished surface (includes coverage on both membrane and substrate) shall be achieved. **Apply** adhesive evenly, without globs or puddles with a plastic core, medium nap paint roller to achieve continuous coating of both surfaces. A 9-inch roller will easily fit into the 5-gallon containers.

A mechanical roller dispenser can be used to apply Bonding Adhesive when the continuous coating and coverage rate noted above are maintained.

CAUTION: Due to solvent flash-off, condensation may form on freshly applied Bonding Adhesive when the ambient temperature is near the dew point. If condensation develops, possible surface contamination may occur and the application of Bonding Adhesive must be discontinued. Allow the surface to dry and apply a thin freshener coat at the coverage rate which is approximately half the coverage rate stated above to the previously coated surface when conditions allow for continuing.

NOTE: When Aqua Base 120 is specified refer to Spec Supplement G-09-22 "Aqua Base 120 Bonding Adhesive" for application methods.

6. **Allow** adhesive to dry until tacky but will not string or stick to a dry finger touch.

CAUTION: Care must be exercised to ensure proper drying. Avoid thin areas of adhesive because over drying can occur and proper adhesion may not be achieved.

7. **Roll** the coated membrane into the coated substrate while avoiding wrinkles.
8. **Brush** down the bonded section of the membrane sheet immediately after rolling the membrane into the adhesive with a soft bristle push broom to achieve maximum contact.
9. **HydroBond Adhesive** can be applied directly to the substrate using an airless spray machine or a medium nap roller. Do not apply HydroBond to splice areas to be hot-air welded. When applying HydroBond, ensure that the adhesive has not dried before the membrane is laid in place. This is a wet lay-in adhesive; drying occurs rapidly during high temperatures, and care must be taken to ensure the membrane is laid into wet adhesive. To ensure a wet lay-in, adjust the application technique according to weather conditions. Avoid heavy or thin application of adhesive. Roll the membrane into the wet, adhesive coated substrate while avoiding wrinkles. Immediately brush down the bonded portion of the membrane with a soft-bristle push broom or a clean, dry roller applicator to achieve maximum contact and to work out any air bubbles. Immediately after brooming out from the center, roll the membrane in all directions with a minimum 100–150-lb (45–68 kg) weighted roller to achieve maximum contact.

NOTE: When using Hydrobond Adhesive, do not apply when the surface and/or ambient temperatures are below 40 degrees or when the temperature is expected to drop below 32 degrees within 72 hours of application. Hydrobond Adhesive is a wet lay-in, one-sided adhesive with coverage rate is 100-133 square feet per gallon finished surface.

10. **Fold** back the unbonded half of the sheet and repeat the bonding procedures. **Apply** Bonding Adhesive to the remaining exposed underside of membrane and adjacent substrate and complete this section as described above.
11. **Install** adjoining membrane sheets in the same manner, overlapping edges a minimum of 2 inches to provide for a minimum 1-1/2 inch heat weld. It is recommended that all splices be shingled to avoid bucking of water.

CAUTION: If aesthetics are of concern, protect completed sections of the roof so Bonding Adhesive will not discolor the membrane surface. Do not place Bonding Adhesive containers or their lids directly on the surface of the WeatherBond TPO membrane.

D. Membrane Securement / Fastening - Mechanically Attached Roofing Systems

1. Thermoplastic membranes shall be mechanically attached to the structural deck with specified WeatherBond Fasteners and designated Plates, for fastening densities and numbers of perimeter sheets refer to Tables,

Paragraph 1.05.

2. Membrane Fastening Selection Table:

Membrane Fastener Selection

Deck Type	WeatherBond Fasteners*	WeatherBond Plate	Min. Penetration
Steel or Lightweight Insulating Concrete over Steel**	HPWX	HPWX Plates	3/4"
	HPW-XL	HPW-XL Plates	
Structural Concrete, rated 3,000 psi or greater	CD-10	HPWX Plates	1"
	MP 14-10	HPWX Plates	
Wood Plank, min. 15/32" thick Plywood or min. 7/16" OSB**	HPWX	HPWX Plates	Min. 1"
	HPW-XL	HPW-XL Plates	
Cementitious Wood Fiber	Polymer Gyptec	Gyptec Plates – 2" Dia.	1-1/2"
Gypsum	Polymer Gyptec	Gyptec Plates – 2" Dia.	1-1/2"

Refer to Tables in Paragraph 1.05 for fastening densities and number of perimeter sheets.

*Determine proper fastener length for deck penetration, refer to Table 2.05B.

**For mechanically attached PVC assemblies, 2-3/4" x 1-1/2" oval metal barbed fastening plates can be used in conjunction with HPWX fasteners for membrane securement. (Not recommended for insulation Securement)

- On steel decks, membrane shall be positioned with seams perpendicular to the steel deck flutes. This allows the external forces on the roof assembly to be distributed between multiple steel deck panels. Refer to Design Reference DR-06-22 "Withdrawal Resistance Criteria".

4. Perimeter Sheets

The number of perimeter sheets and fastener spacing is dependent on the building height and wind zone location as outlined in Tables in Paragraph 1.05.

The roof perimeter is defined as all edges of each roof section (i.e., parapets, building expansion joints at adjoining walls, penthouse walls, etc.). When multi-level roofs meet at a common wall, the adjacent edge of the upper roof is treated as a roof perimeter if the difference in height is greater than 3'. Perimeter sheets are not required at the base of the wall at the lower level.

NOTE: Expansion joints, control joints and fire walls in the field of the roof or roof ridges with slopes less than 3" to the horizontal foot are not considered as part of the roof perimeter.

For WeatherBond TPO membranes, perimeter sheets can be formed by using individual 4' to 6' wide sheets or by sub-dividing 8' or 10' wide field sheet using 10" wide Pressure-Sensitive RUSS strip or row of seam fastening plates as described below.

a) **Individual perimeter sheets** (TPO – 4', 5' or 6' wide)

Position membrane along the perimeter of the roof over the acceptable insulation/underlayment. The perimeter membrane width from line of securement to line of securement should be approximately 3'-6" to 4'-0" wide.

b) **RUSS - Reinforced Universal Securement Strip (WeatherBond TPO Membrane Only)**

1) When **field sheets are positioned parallel to a roof perimeter, 10" wide WeatherBond TPO Pressure-Sensitive RUSS** (with 3" wide tape each side) shall be placed approximately down the center of the 8'-0", 10'-0" or 12'-0" wide WeatherBond TPO field membrane sheets. When a RUSS divides a field sheet in half, two perimeter sheets are created.

2) When field membrane sheets **extend perpendicular to the edge of the roof**, position the **10" wide WeatherBond TPO Pressure-Sensitive RUSS** beneath the membrane along the center of each field sheet extending a distance equal to 0.4 times the building height to create perimeter sheets.

CAUTION: 6" wide WeatherBond TPO Pressure-Sensitive RUSS is only available with 3" wide P&S Seam Tape on one side and therefore cannot be used to form perimeter sheets.

c) **Fastening Plates Method**

In lieu of the RUSS securement method, position a row of seam fastening plates in the locations identified in Paragraph 4.b.1 and 4.b.2, secure plates with appropriate fastener and overlay plates either 6" wide

Pressure-Sensitive TPO Cover Strip (TPO Only) overlay the plates as follows:

- 1) WeatherBond TPO Installation – 6" wide Pressure-Sensitive TPO Cover Strip or 6" wide WeatherBond TPO membrane centered over the plates and heat welded to the field membrane. Seal cut edges of TPO overlay with TPO Cut-Edge Sealant to seal any exposed scrim.

d) **Building with Special Conditions:**

Air pressurized buildings, canopies and buildings with large openings where the total wall openings exceed 10% of the total wall area on which the openings are located (such as airport hangars, warehouses and large maintenance facilities) will typically require additional perimeter membrane securement, an increased fastening density or other enhancement.

e) **Buildings with large openings**

When any wall contains major openings with a combined area which exceeds 10% of the total wall area on which the openings are located, four (4) perimeter sheets (centered over the opening) must be specified as shown.

As an option to the above perimeter securement, a fully adhered membrane section may be used in lieu of the mechanically attached membrane at large openings in accordance with the WeatherBond Specification for the WeatherBond TPO/Fully Adhered Roofing System.

NOTE: Depth of perimeter area, noted above, shall not be less than 2.5 times the width of the opening.

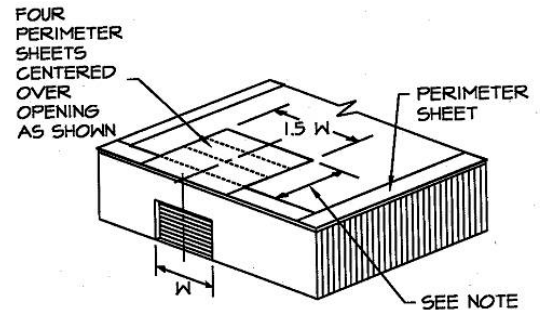

f) **Buildings with overhangs**

The membrane must be specified with perimeter sheets installed over the entire overhang area extending onto the main roof deck when at the same level.

As an option, a fully adhered membrane section may be used in lieu of the mechanically attached membrane at building overhangs in accordance with the WeatherBond Specification for the WeatherBond Fully Adhered Roofing System.

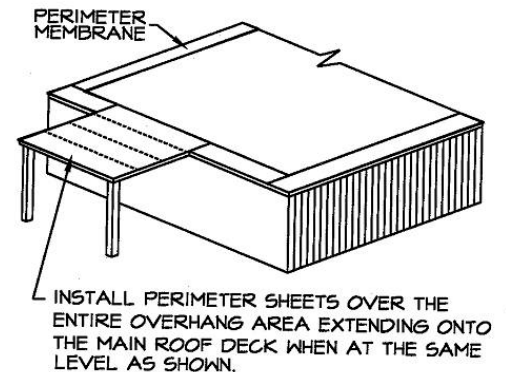

5. **Field Membrane**

- a) **Position** adjoining field membrane sheets to allow an approximate overlap of 5-1/2" at those locations where Fastening Plates are located (along the length of the membrane); at the same time overlap end roll sections (the width of the membrane) a minimum of 2".
- b) **Secure the membrane** at the approved fastening density with the required WeatherBond Fastener and Fastening Plates.
- c) For installation of membrane with fullness, tighten the sheet between fasteners as follows:
 - 1) Unroll sheets and position.

- 2) Place a fastener and plate in one end of the sheet on the appropriate fastener mark. Go to the opposite end of the sheet, pull it tight and place a fastener and plate at the appropriate mark. Place the remaining fasteners into the sheet.
- 3) Proceed to weld the sheet in place and continue across the roof.

6. **Prevention of membrane distortion during windy conditions:**

- a) Unroll sheet approximately 5' and position edge of membrane with overlap line on adjacent sheet.
- b) Install fasteners along the 5' exposed edge.
- c) While the 5' of exposed membrane is being fastened, begin welding the overlapped edge using the Automatic Heat Welder.
- d) As sheet is being welded and fastened concurrently, unroll membrane. Unroll only enough membrane to stay a few feet ahead of welding and fastening process. This reduces amount of unsecured membrane to be distorted by wind.
- e) Continue this process for each adjoining sheet.

E. **WeatherBond PAS TPO (Peel & Stick TPO) – Roofing System (membrane bonding)**

10' wide WeatherBond PAS TPO is fully adhered to an approved insulation or substrate with Factory Applied Peel & Stick Adhesive.

1. **Position** WeatherBond PAS TPO membrane over the acceptable substrate.
2. **Fold** membrane sheet back so half the underside is exposed.
3. **Remove** the release liner on one half of the sheet starting from the split in the liner at the middle of the sheet. The liner should be removed at an angle to reduce risk of splitting or tearing.
4. **Roll** the membrane onto the substrate while avoiding wrinkles. To achieve the best adhesion, the membrane should be rolled onto the substrate at an angle with 150 lb weighted segmented roller. When applying the WeatherBond PAS TPO membrane it is recommended to maintain a large curve on the leading edge of the membrane. This will help eliminate creases and bubbles that cannot be removed after the sheet is in place.
5. **Fold** back the remaining half of the sheet and repeat the above process.

F. **Additional Membrane Securement**

1. Securement must be provided at the perimeter of each roof level, roof section, expansion joint, curb, skylight, interior wall, penthouse, etc., at any inside angle change where slope exceeds 2 inches to one horizontal foot, and at all penetrations as identified on the WeatherBond details.
2. Securement may be achieved as follows:
 - a) On Mechanically Attached Roofing Systems, WeatherBond's HPWX Fastening Plates are used to secure the membrane with the appropriate WeatherBond Fastener at the base of walls and penetrations and flashed as shown on the applicable WeatherBond detail (excluding OSB, cementitious wood fiber and gypsum decks where the required WeatherBond Fastener is installed with the associated 2" diameter plate). On **Fully Adhered Roofing Systems**, WeatherBond standard 2" diameter Seam Fastening Plates may be used in lieu of HPWX Plates.
 - b) Securement of the membrane shall be a maximum of 12 inches on center. Starting 6 inches minimum to 9 inches maximum from the inside or outside corner.
 - c) On Mechanically Attached assemblies, additional membrane securement is required around pipes and sealant pockets as shown on the applicable detail. The plates must be positioned a maximum of 12" away from the penetration, spaced a maximum of 12" on center and flashed in accordance with the applicable WeatherBond Detail.
 - d) After securing the membrane, flash in accordance with the appropriate detail.

3.06 Heat Welding Procedures

A. General

1. APEEL Protective Film should be removed from within areas that are to be heat-welded together. In areas that do not require heat welding, the APEEL Protective Film can be left in place for up to 90 days.
2. Heat weld the WeatherBond TPO membrane sheets using the Automatic Heat Welder or Hot Air Hand Welder and silicone roller.
3. When roof slope exceeds 5" per horizontal foot, use of the Automatic Heat Welding Machine may become more difficult; use of the Hand Held Hot Air Welder is recommended.
4. **Check the surfaces** of the membrane to be heat welded to ensure they are properly prepared.

The surfaces to be heat welded must be clean. Membrane overlaps that become contaminated with field dirt must be cleaned with Weathered. Weathered Membrane Cleaner should be wiped dry with a clean Splice Wipe prior to welding. No residual dirt or contaminants should be evident.

B. Automatic and/or Hand Held Heat Welder Equipment

Refer to **Spec Supplement T-01-22 "Heat Welding Equipment"** for:

- a) Temperature Settings
- b) Equipment Set-up
- c) Additional Information

C. Membrane Welding

1. Prepare the Automatic Heat Welder and allow it to warm for approximately 5 to 10 minutes to reach operating temperature.
2. Position the Automatic Heat Welder properly prior to seaming with the guide handle pointing in the same direction the machine will move along the seam.
3. Lift the overlapping membrane sheet and insert the blower nozzle of the Automatic Heat Welder between the overlap. Machine will begin moving along the seam immediately.
4. Weight plates provided on Automatic Welders must be utilized.
5. Proceed along the seam ensuring that the small guide wheel in front of the machine aligns with the edge of the top membrane sheet. Guide the machine from the front only.

CAUTION: Ensure the power cord has plenty of slack to prevent dragging the machine off course (which could result from a tightly stretched cord).

6. At all splice intersections, roll the seam with a silicone roller to ensure a continuous heat welded seam (the membrane should be creased into any membrane step-off with the edge of the silicone roller). A false weld may result due to surface irregularities created by multiple thicknesses of WeatherBond TPO membrane sheets.

When using **60-mil or 80-mil** WeatherBond TPO, a **TPO "T" Joint Cover** must be applied over all "T" joint splice intersections.

7. To remove the Automatic Heat Welder from the finished splice, disengage and pull the nozzle from the seam area, the machine will stop automatically.
8. Mark the end of the heat welded seam with a water-soluble marker for easy identification. A Hand Held Welder will be necessary to complete the weld in the area between where the Automatic Heat Welder is stopped and restarted.
9. Perform a test weld, at least, at the start of work each morning and afternoon. Test welds should be made if any changes in substrate or weather conditions occur.
10. All membranes, at end laps, a minimum 6" wide, reinforced coverstrip must be used in conjunction with applicable primer.

D. Preventing Membrane Creeping During Welding

1. The operator of automatic welding equipment must apply foot pressure to the membrane, keeping the membrane tight under the welder. Refer to **Spec Supplement T-01-11 "Heat Welding Equipment"** for additional information.

E. Test Cuts

1. Perform a test weld at least at the start of work each morning and afternoon. Refer to **Spec Supplement T-01-22 "Heat Welding Equipment"** for additional information.

F. Seam Probing

1. A cotter pin puller or WeatherBond TPO Seam Probe is recommended to probe all heat-welded seams. Probing seams must be done once heat welds have thoroughly cooled. Refer to **Spec Supplement T-01-22 "Heat Welding Equipment"** for additional information.

G. Cut-Edge Sealant

1. Apply Cut-Edge Sealant on all cut edges of the WeatherBond TPO reinforced membrane (where the scrim reinforcement is exposed) **after seam probing** is completed. When a 1/8" diameter bead of Cut-Edge Sealant is applied, approximately 225 – 275 linear feet of coverage per squeeze bottle can be achieved.
 - a) Cut-Edge Sealant is not required on vertical WeatherBond TPO splices.

3.07 Welding Problems / Repairs

- A. A Handheld Hot Air Welder and a 2" wide silicone roller must be used when repairing the WeatherBond TPO membrane. When the **entire** heat welded **seam** is to be **overlaid**, an **Automatic Heat Welder** may be used.
- B. Prior to proceeding with any repair procedure, the area to be repaired must be cleaned with Weathered Membrane Cleaner / TPO Membrane Cleaner. The membrane can typically be repaired with standard cleaning methods. In cases where the standard cleaning method is not sufficient, the following procedures must be used.
 1. Scrub the area to be welded with a "Scotch Brite" Pad and Weathered Membrane Cleaner (TPO).
 2. Clean all residue from the area to be welded with a Splice Wipe or a clean natural fiber (cotton) rag.
 3. Weld the new membrane to the cleaned area using standard welding procedures.
- C. Voids in welded seams can be repaired using a Hand-held Hot Air Welder and a silicone roller. Depending on conditions, a splice overlay may be required.
- D. Position the hand-held welder facing into void so hot air is forced between overlapping membranes. Roll the top membrane surface using positive pressure toward the outer edge until the heated membrane surfaces are fused.
- E. Exposed scrim-reinforcement (resulting from scorching surface of membrane) and test weld areas must be repaired by overlaying the damaged area with a separate piece of WeatherBond PRO TPO/WeatherBond PRO PVC reinforced membrane with rounded corners. The overlay must extend a minimum of 2 inches past the area to be repaired.
- F. **Probe** all edges of the overlay once cooled to ensure a proper weld has been achieved.
- G. **Seal** all cut edges of WeatherBond TPO reinforced membrane with Cut-Edge Sealant.

Note: The same overlay repair procedures may be used for puncture in the WeatherBond TPO membrane.

3.08 Flashings

A. General Considerations

1. The height of new wall flashing must extend above the anticipated water level or slush line.
2. WeatherBond's Termination Bar, in conjunction with Water Cut-Off Mastic, is recommended under all metal counterflashings and surface mounted reglets.

3. To comply with various options, flashing material must equal the required minimum membrane thickness but shall not be less than 60 mils thick.
4. For wall and curb flashing, the required thickness shall equal the deck membrane thickness.
5. **On Retrofit Projects**

Bitumen-based roof cement and asphaltic-based flashing material, if allowed to remain in contact with the membrane, will cause severe membrane discoloration. Existing wall and curb flashing must be removed or concealed with a new acceptable substrate.

- a) The specifier must examine structural supports for rooftop equipment to determine if reasonable access to the membrane beneath the equipment is provided. WeatherBond should be consulted for clarification when access to the membrane system will be restricted.
 - b) When hot pipes or other similar penetrations exceed 160°F (71°C) (TPO), they must be designed to incorporate an insulated metal collar and rain hood designed to maintain a surface temperature less than 160°F (71°C) (TPO).
6. When possible, all reinforced membrane splices are heat welded with the Automatic Heat Welder. The Handheld Hot Air Welder should be utilized in hard to reach areas, smaller curbs, vertical splices and when using non-reinforced membrane.
 - a) The new WeatherBond TPO membrane flashing must not conceal weep holes or cover existing throughwall flashing.
 - b) Install surface mounted reglets and compression bar terminations directly to the wall surface.
 7. In areas where metal counterflashing or surface mounted reglets are used as vertical terminations, the counterflashing must be sealed with a rubber grade caulking to prevent moisture migration behind the new wall flashing.

B. **Application of Bonding Adhesive**

1. Membrane shall be fully adhered to vertical surfaces with WeatherBond TPO Bonding Adhesive. CAV-GRIP III low-VOC aerosol adhesive may be utilized with WeatherBond TPO membranes. Bonding Adhesive shall be applied continuously, without globs or puddles.
2. **Allow** adhesive to flash-off until it is tacky but will not string or transfer to a dry finger touch.
3. Roll the membrane into the adhesive.
4. Care must be taken when setting the flashing to avoid bridging greater than 3/4 inch at angle changes (i.e., where a parapet or roof penetration meets the roof deck). This can be accomplished by creasing the membrane into the angle change.
5. Terminate the edges of the installed membrane in accordance with WeatherBond's applicable details.
6. When using TPO membrane flashing only, bonding adhesive is not required when the flashing height is 12" or less. When WeatherBond termination bar is used beneath the counter-flashing, bonding adhesive can be eliminated when the flashing height is 18" or less.

C. **Walls, Parapets, Curbs, Skylights, etc.**

The flashing height must be calculated so that the WeatherBond membrane flashing includes a minimum 1-1/2 inch heat weld beyond the Fastening Plates.

1. Fasten at angle change as identified in **Paragraph 3.08**, Additional Membrane Securement, with the required WeatherBond Fastener and plate.
2. Flash the fasteners/plates with a separate piece of WeatherBond TPO reinforced membrane; apply heat and crease the flashing into the angle change before attaching it to the vertical surface.

D. **Metal Edge Terminations**

Factory-fabricated metal edge systems must be secured to the wood nailer as specified by the manufacturer. Shop-fabricated edging must be installed in compliance with appropriate WeatherBond Detail using WeatherBond TPO Coated Metal in order to achieve ES-1 Compliance. Refer to the appropriate Common Details for other flashing options and requirements.

E. **Roof Drains**

1. WeatherBond TPO membrane may extend into the drain sump when the slope of the sump is less than 3" to one horizontal foot.

When the drain sump is greater than 3" to one horizontal foot, additional membrane securement must be installed.

2. Only drain strainers that have been approved by the specifier in accordance with applicable codes may be used.

F. **WeatherBond TPO Rib Profiles**

1. WeatherBond TPO Rib Profiles are recommended for use with Fleece adhered roofing systems.
2. The WeatherBond TPO Rib Profiles should be positioned parallel to the laps of the installed TPO roofing system and parallel with the roof slope where possible.
3. Ensure that all welding surfaces are clean and dry. Inspect all seam areas for proper weld prior to installing WeatherBond TPO Rib Profile.
4. Rib Profile spacing can be individually determined to achieve the desired appearance.
5. Connecting multiple ribs is achieved by using fiberglass pins. Insert a pin half-way into the end of one profile. Connect the adjoining rib by inserting the exposed end of the pin into the alignment hole. Repeat previous steps for additional TPO Rib profiles.
6. Consult the WeatherBond TPO Rib Profile installation guides for instructions on proper installation techniques.

G. **Other Penetrations**

On Mechanically Attached assemblies, additional membrane securement is required around pipes and sealant pockets as shown on the applicable detail. The plates must be positioned a maximum of 12" away from the penetration, spaced a maximum of 12" on center and flashed in accordance with the applicable WeatherBond Detail.

1. **Pipes, Round Supports, etc.**

- a) Flash pipes with Molded Pipe Flashings or Split Pipe Seals where their installation is possible. Molded pipe flashings cannot be cut and patched; deck flanges cannot be overlapped or installed over angle changes.
- b) Where Molded Pipe Flashings or Split Pipe Seals cannot be installed, APPLY FIELD FABRICATED PIPE FLASHING using WeatherBond TPO non-reinforced membrane.

2. **Flexible Penetrations** (braided cables, conduits, wires, etc.) must be enclosed in a stable "goose neck." Apply a Split Pipe Seal or field fabricated pipe flashing to flash the goose neck.
3. **Hot pipes** that exceed 160°F (71°C) (TPO), must utilize an insulated metal collar and rain hood, flashed with a field fabricated pipe flashing.
4. For **pipe clusters** or unusually shaped penetrations, a Molded Sealant Pocket and White One-Part Sealant must be utilized.
5. **Existing Roof Tie-Ins** For TPO membranes refer to applicable WeatherBond details for tie-ins.
6. **Flashing of Difficult Penetrations**, refer to Spec Supplement G-11-22 for "LIQUISEAL Liquid Flashing" for additional information and specific requirements.

H. **APEEL Protective Film (Optional)**

When the optional APEEL Protective Film is utilized on TPO, remove and discard the APEEL Protective Film after the installation of the entire TPO Roofing System is complete.

3.09 Roof Walkways

Walkways are to be specified at all traffic concentration points (i.e., roof hatches, access doors, rooftop ladders, etc.), and if regular maintenance (once a month or more) is necessary to service rooftop equipment. **Refer to Spec Supplement G-05-22 “Roof Walkway Installation”.**

3.10 Daily Seal

On phased roofing, when the completion of flashings and terminations is not possible by the end of each workday, provisions must be taken to temporarily close the membrane to prevent water infiltration. **Refer to Spec Supplement G-06-22 “Daily Seal & Clean Up”.**

Copyright 2024 WeatherBond
WeatherBond is a Trademark of WeatherBond

Insulfoam, InsulLam and R-Tech are Trademarks of Insulfoam
Thermapink, Foamular and Durapink are Trademarks of Owens Corning
Styrofoam is Trademark of the DOW Chemical Company
Olybond is a Trademark of OMG, Inc.

This specification represents the applicable information available at the time of its publication. Owners, specifiers and Roofing Contractors should consult WeatherBond or their WeatherBond Independent Sales Representative for any information, which has subsequently been made available.



WEATHERBOND ROOFING SYSTEMS

WeatherBond TPO Mechanically Attached and Fully Adhered Roofing Systems

Installation Details Table of Contents

January 2024

	Detail
Mechanically Attached	
Membrane Securement.....	WPMA-2.0A
TPO Membrane Securement with Peel & Stick RUSS.....	WPMA-2.0B
Mechanically Attached Membrane Splice, Page 1 of 2.....	WPMA-2.1
Mechanically Attached Membrane Splice, Page 2 of 2.....	WPMA-2.1
Ridge Membrane Attachment.....	WPMA-22.0
Metal Edges and Gravel Stops	
TPO Drip Edge Fascia.....	WP-1.1
TPO Heat Weldable Drip Edge.....	WP-1.2
Metal Bar Edge Termination.....	WP-1.3
Membrane Splices	
Membrane Splice.....	WP-2.0
TPO Membrane Splice.....	WP-2.1
Expansion Joints	
Deck-to-Deck Expansion Detail.....	WP-3A.1
Deck-to-Deck Expansion Detail.....	WP-3.1
Deck-to-Wall Expansion Detail.....	WP-3.2
Curb Flashing	
Curb Flashing.....	WP-5.1
Coated Metal Curb Flashing.....	WP-5.2
Pre-Fabricated TPO Curb Wrap Corner.....	WP-5.3
Self Flashing Curb.....	WP-5.4
Drains	
Roof Drain (Drain Sump Up to 3 inches to 1 Horizontal Foot).....	WP-6.1
Roof Drain (Drain Sump Greater than 3 inches to 1 Horizontal Foot) Option 1.....	WP-6.2
Roof Drain (Drain Sump Greater than 3 inches to 1 Horizontal Foot) Option 2, Page 1 of 2.....	WP-6.3
Roof Drain (Drain Sump Greater than 3 inches to 1 Horizontal Foot) Option 2, Page 2 of 2.....	WP-6.3
Add-On Drain.....	WP-6.4
Pipe Flashing	
Pre-Molded Flashing.....	WP-8.1
Field Fabricated Pipe Flashing.....	WP-8.2
Pre-Fabricated Square Tube Wrap.....	WP-8.3
Field-Fabricated Square Tube Flashing.....	WP-8.4
Pre-Fabricated Split Pipe Seal.....	WP-8.5
Hot Pipe Flashing.....	WP-8.6
Terminations	
Membrane Terminations, Page 1 of 3.....	WP-9.0A
Membrane Terminations, Page 2 of 3.....	WP-9.0B
Membrane Terminations, Page 3 of 3.....	WP-9.0C

Moisture Relief Vent for MF System.....	WBPC-9.1
Low-Slope Roof: Sealing the Underside of the Deck to Prevent Condensation	WBPC-9.2

Parapet Flashing

Parapet Flashing	WBPC-12.1
Parapet Flashing with Pressure-Sensitive RUSS, Page 1 of 2.....	WBPC-12.2A
Parapet Flashing with Pressure-Sensitive RUSS, Page 2 of 2.....	WBPC-12.2B
Coated Metal Wall Flashing	WBPC-12.3
Parapet Flashing / No Adhesion – Any Height Option.....	WBPC-12.6
Weatherbond PAS TPO Parapet Flashing with TPO PAS RPS	WBPC-12.7
WeatherBond PAS Parapet Flashing with Weatherbond PAS RPS.....	WBPC-12.8

Tie-Ins

TPO Tie-In To Built-Up Roofing Over Steel Roof Deck.....	WBPC-13.1
TPO Tie-In To Built-Up Roofing Over Concrete Roof Deck.....	WBPC-13.2
TPO Tie-In To Existing Single-Ply.....	WBPC-13.3
TPO Tie-In to Existing EPDM Membrane.....	WBPC-13.4
EPDM Tie-In on Concrete Deck	WBPC-13.5
TPO Tie-In to Shingled Roof	WBPC-13.6

Inside / Outside Corners

Pre-Molded Inside Corner Flashing.....	WBPC-15.1
Field Fabricated Inside Corner Flashing.....	WBPC-15.2
Inside Corner with Coated Metal Flashing.....	WBPC-15.3
Pre-Molded Outside Corner Flashing.....	WBPC-15.4
Field Fabricated Outside Corner Flashing.....	WBPC-15.5
Outside Corner with Coated Metal Wall Flashing	WBPC-15.6
TPO: Universal Corners – Combination Inside & Outside Corners	WBPC-15.7

Sealant Pocket

Molded Sealant Pocket	WBPC-16.1
Field Fabricated TPO Coated Metal Pocket.....	WBPD-16.2

Through-Wall Scupper

Scupper with Coated Metal	WBPC-18.1
Scupper at Deck – TPO	WBPC-18.2

Lightning Rods

Lightning Rod at Parapet (Vertical Attachment)	WBPC-20.1
Lightning Rod at Deck Level	WBPC-20.2

GUIDELINES FOR ROOF PERIMETER ZONES FOR MECHANICALLY ATTACHED ROOF SYSTEM

SPLIT LEVEL ROOFS

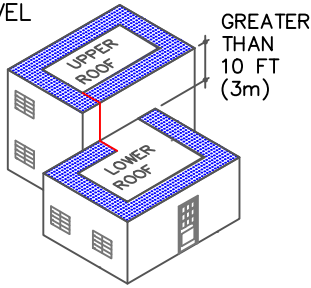

SPLIT LEVEL ROOFS

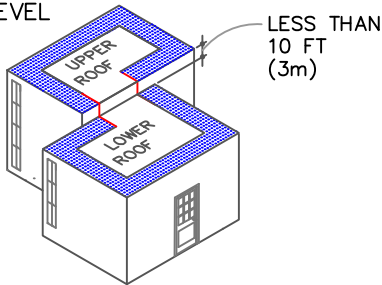

CANOPY ROOF

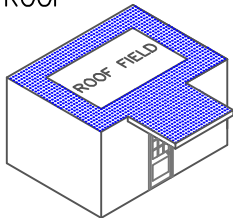

INSTALL PERIMETER SHEETS OVER THE ENTIRE OVERHANG (PROJECTION ROOF) AREA, EXTENDING ONTO THE MAIN ROOF DECK WHEN AT THE SAME LEVEL AS SHOWN.

LARGE OPENINGS OR LOADING DOCKS

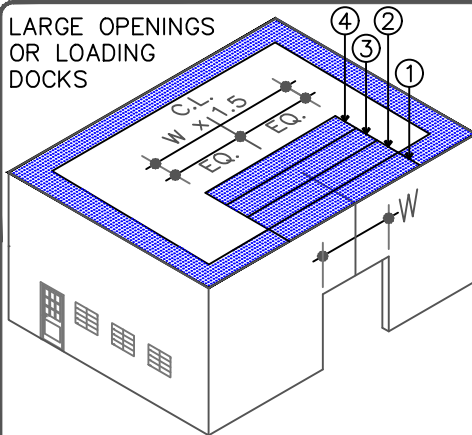

FOUR PERIMETER SHEETS CENTERED OVER LARGE OPENINGS

PERIMETER ZONES

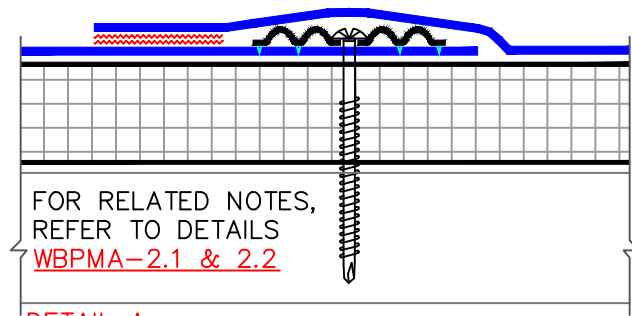
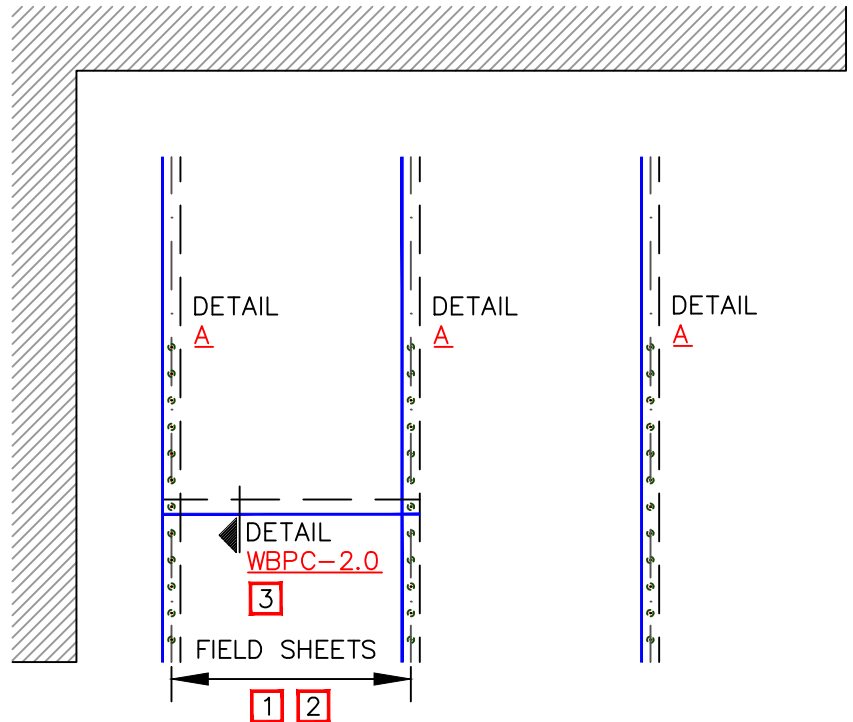

FOR RELATED NOTES, REFER TO DETAILS [WBPMA-2.1 & 2.2](#)

DETAIL A

NOTES:

1. WHEN USING 10' (3m) OR 12' (3.7m) WIDE TPO FIELD SHEETS, 6' (1.8m) WIDE PERIMETER SHEETS ARE UTILIZED. WHEN USING 8' (2.4m) WIDE TPO FIELD SHEETS, 4' (1.2m) WIDE PERIMETER SHEETS ARE USED. WHEN USING 10' (3m) WIDE PVC FIELD SHEETS, 5' (1.5m) WIDE PERIMETER SHEETS ARE UTILIZED. WHEN USING 81" (2.1m) WIDE PVC FIELD SHEETS, 40.5" (1m) WIDE PERIMETER SHEETS ARE USED.
2. REFER TO WEATHERBOND SPECIFICATIONS FOR REQUIRED NUMBER OF PERIMETER SHEETS, SHEET WIDTH AND MEMBRANE FASTENING DENSITY.
3. END LAPS DO NOT REQUIRE MECHANICAL FASTENING AND SHALL BE OVERLAPPED 2" (5cm) MINIMUM. REFER TO WEATHERBOND [DETAIL WBPC-2.0](#).



WEATHERBOND
ROOFING SYSTEMS
© 2024 WeatherBond

MEMBRANE SECUREMENT

- TPO MEMBRANE
- APPROVED SUBSTRATE
- 0 —● SEE NOTE

THERMOPLASTIC ROOFING SYSTEM

WBPMA-2.0A

GUIDELINES FOR ROOF PERIMETER ZONES FOR MECHANICALLY ATTACHED ROOF SYSTEM

SPLIT LEVEL ROOFS

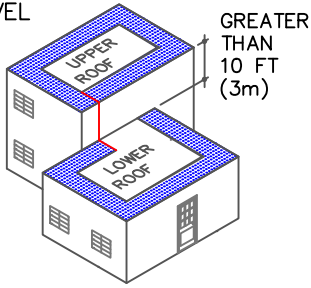

SPLIT LEVEL ROOFS

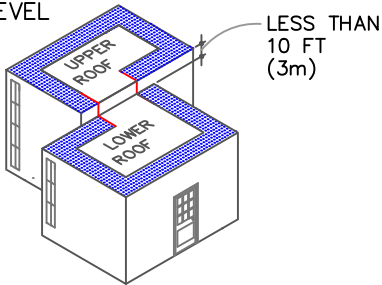

CANOPY ROOF

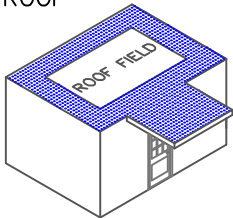

INSTALL PERIMETER SHEETS OVER THE ENTIRE OVERHANG (PROJECTION ROOF) AREA, EXTENDING ONTO THE MAIN ROOF DECK WHEN AT THE SAME LEVEL AS SHOWN.

LARGE OPENINGS OR LOADING DOCKS

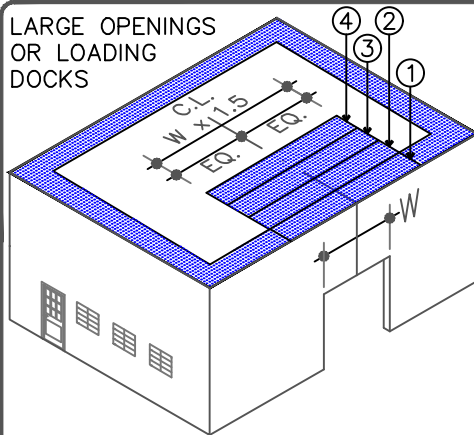

FOUR PERIMETER SHEETS CENTERED OVER LARGE OPENINGS

PERIMETER ZONES

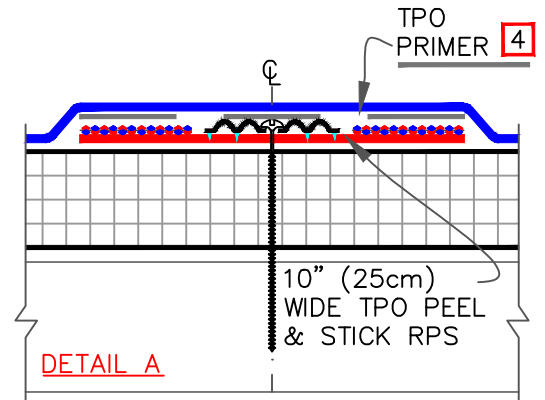
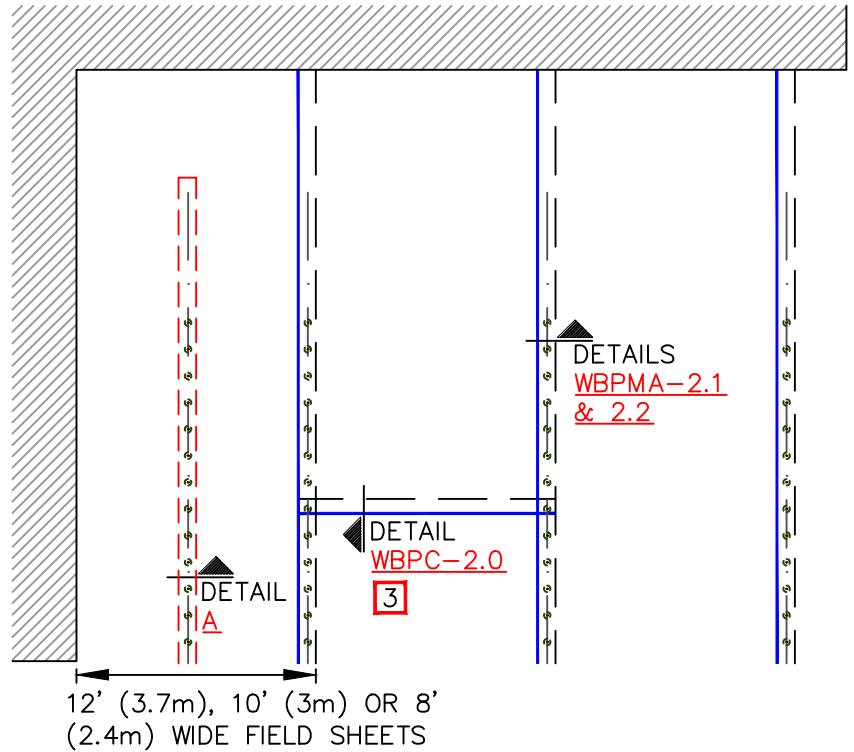

NOTES:

1. PEEL & STICK RPS SHALL BE POSITIONED 5' (1.5m) TO 6' (1.8m) FROM THE PERIMETER EDGE WHEN USING 10' (3m) OR 12' (3.7m) WIDE TPO FIELD SHEETS. WHEN USING 8' (2.4m) WIDE TPO FIELD SHEETS, PEEL & STICK RPS SHALL BE POSITIONED 4' (1.2m) FROM THE PERIMETER EDGE.
2. REFER TO WEATHERBOND SPECIFICATIONS FOR REQUIRED NUMBER OF PERIMETER SHEETS, SHEET WIDTH AND MEMBRANE FASTENING DENSITY.
3. END LAPS DO NOT REQUIRE MECHANICAL FASTENING AND SHALL BE OVERLAPPED 2" (5cm) MINIMUM. REFER TO WEATHERBOND [DETAIL WBPC-2.0](#).
4. TPO PRIMER MUST BE APPLIED TO THE BACK SIDE OF MEMBRANE SURFACE PRIOR TO ADHERING MEMBRANE TO PEEL & STICK RPS.

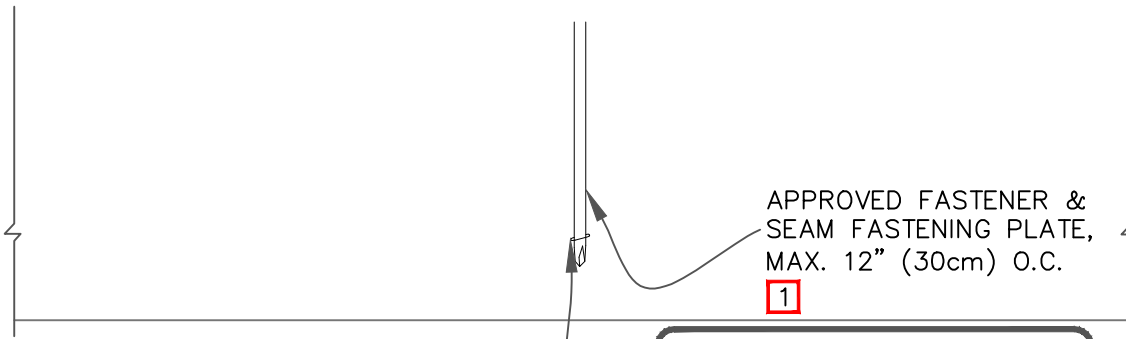

FASTENER & PRESSURE PLATE TYPES FOR DIFFERENT ROOF DECKS			
DECK TYPE	OPTION	FASTENER	PLATE
STEEL OR WOOD	A	HPWX	HPWX
	B	HPW-XL	HPW-XL
STRUCTURAL CONCRETE	A	CD-10	HPWX
	B	MP 14-10	HPWX

T-JOINT REQUIREMENTS

MEMBRANE	THICKNESS		
	45/50	60	80
PVC	N/A	N/A	YES
KEE HP	N/A	N/A	YES
TPO	N/A	YES	YES

NOTES:

1. POSITION SEAM FASTENING PLATES BEYOND NON-REINFORCED ENCAPSULATED EDGE.
2. APPROXIMATELY 1/8" (0.5cm) DIAMETER BEAD OF CUT-EDGE SEALANT IS REQUIRED ON CUT EDGES OF WEATHERBOND REINFORCED TPO MEMBRANE.

WHEN USING 60 OR 80-MIL (1.52/2.03mm) THICK MEMBRANE
 APPLY A 4-1/2" (11.8cm) DIAMETER "T-JOINT" COVER AT FIELD SPLICE INTERSECTIONS, CENTRALLY ALIGNED.

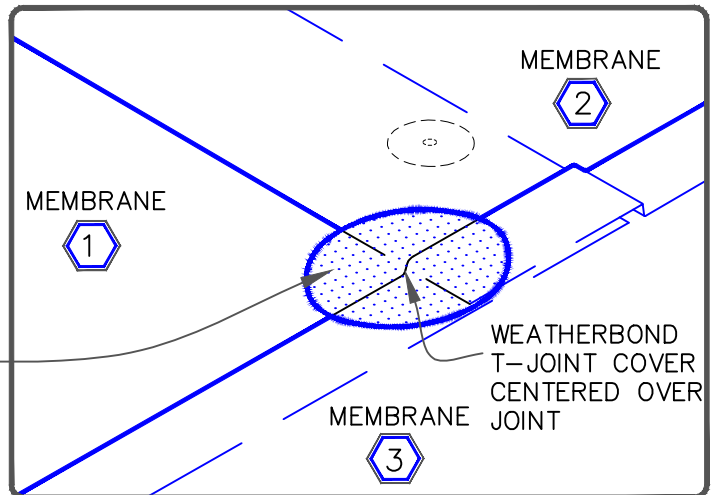

MECHANICALLY ATTACHED SEAM, PAGE 1 OF 2

- TPO MEMBRANE
- APPROVED SUBSTRATE
- SEE NOTE

THERMOPLASTIC ROOFING SYSTEM

WBPMMA-2.1

FASTENER & PRESSURE PLATE TYPES FOR DIFFERENT ROOF DECKS			
DECK TYPE	OPTION	FASTENER	PLATE
STEEL OR WOOD	A	HPWX	HPWX
	B	HPW-XL	HPW-XL
STRUCTURAL CONCRETE	A	CD-10	HPWX
	B	MP 14-10	HPWX

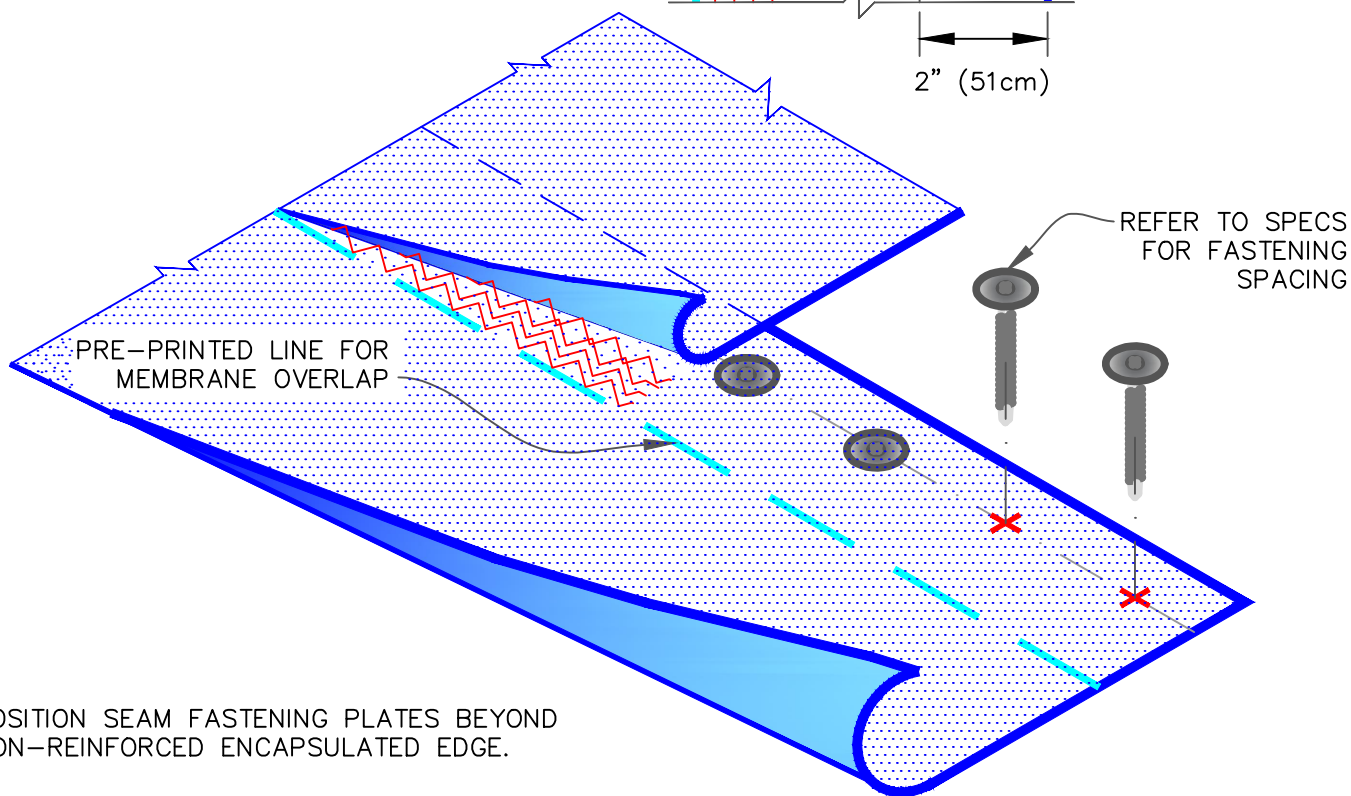
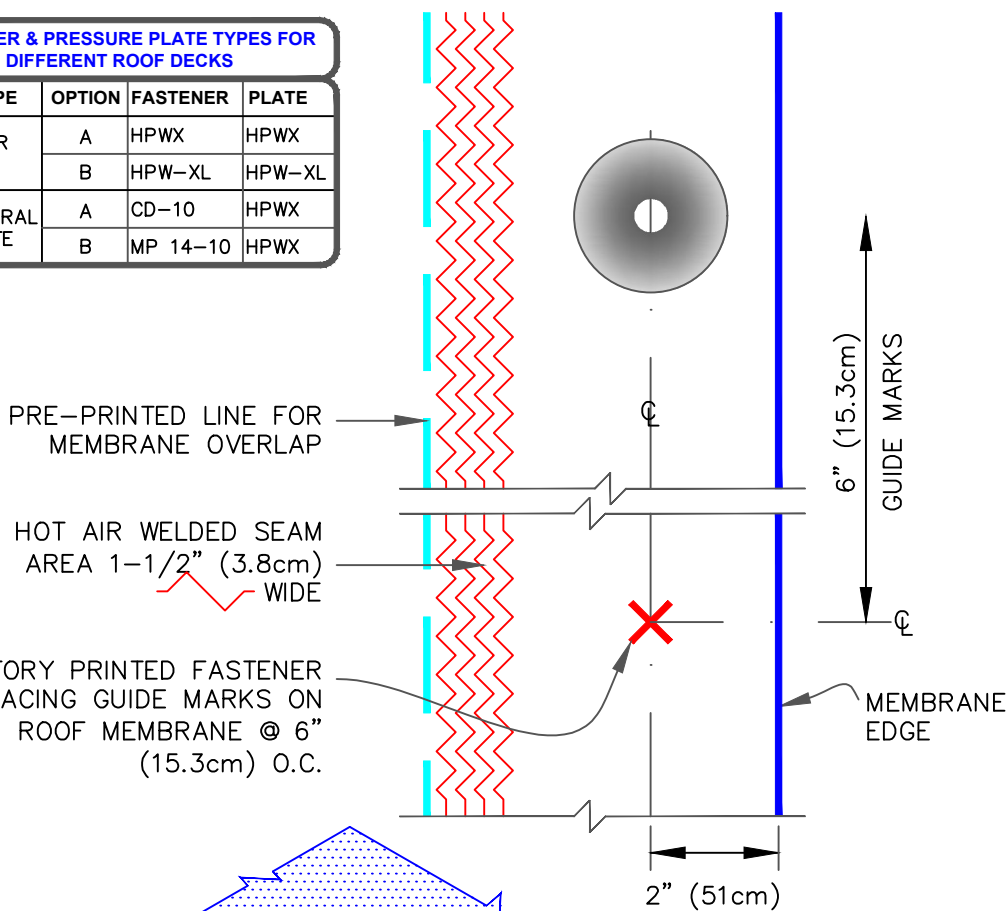

NOTE:

1. POSITION SEAM FASTENING PLATES BEYOND NON-REINFORCED ENCAPSULATED EDGE.



MECHANICALLY ATTACHED SEAM, PAGE 2 OF 2

- TPO MEMBRANE
- APPROVED SUBSTRATE
- 0 —● SEE NOTE

THERMOPLASTIC ROOFING SYSTEM

WBPMA-2.1

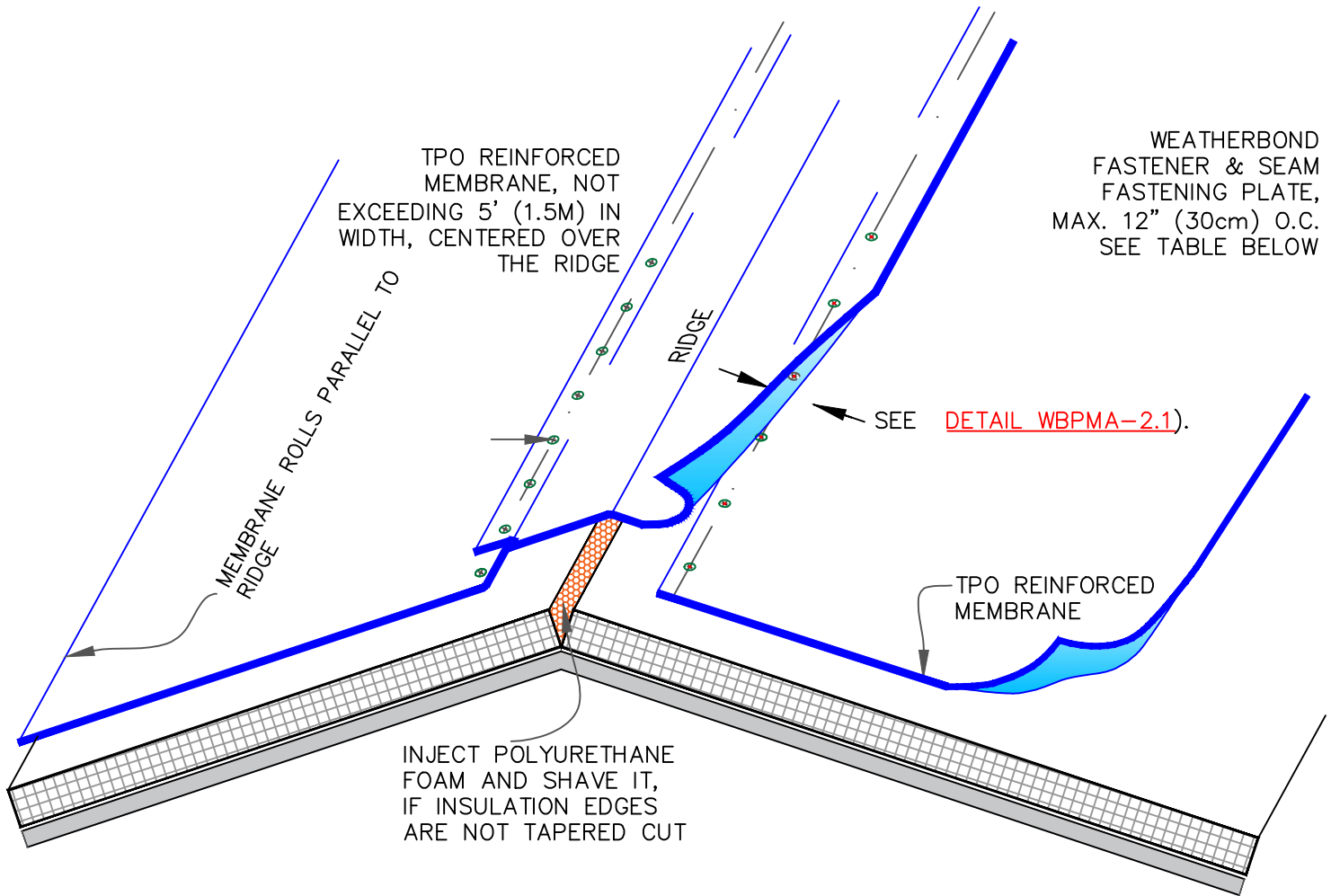

NOTES

1. RIDGE MEMBRANE ATTACHMENT IS ONLY REQUIRED WHEN ROOF SLOPE EXCEEDS 3" TO ONE HORIZONTAL FOOT.
2. REFER TO WEATHERBOND SPECIFICATIONS FOR REQUIRED NUMBER OF PERIMETER SHEETS, SHEET WIDTH AND MEMBRANE FASTENING DENSITY.
3. AS AN OPTION TO USING PERIMETER SHEETS, 10" (25cm) WIDE TPO PEEL & STICK RPS MAY BE USED BENEATH TPO FIELD SHEETS ONLY FOR PERIMETER SECUREMENT. SEE DETAIL [WBPMA-2.0B, DETAIL A](#)
4. APPROXIMATELY 1/8" (0.5cm) DIAMETER BEAD OF CUT-EDGE SEALANT IS REQUIRED ON CUT EDGES OF WEATHERBOND REINFORCED TPO MEMBRANE.

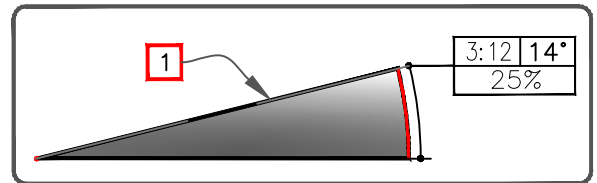

FASTENER & PRESSURE PLATE TYPES FOR DIFFERENT ROOF DECKS			
DECK TYPE	OPTION	FASTENER	PLATE
STEEL OR WOOD	A	HPWX	HPWX
	B	HPW-XL	HPW-XL
STRUCTURAL CONCRETE	A	CD-10	HPWX
	B	MP 14-10	HPWX



RIDGE MEMBRANE ATTACHMENT

- TPO MEMBRANE
- APPROVED SUBSTRATE
- SEE NOTE

THERMOPLASTIC ROOFING SYSTEM

WBPMA-22.0

CAUTION

- **DETAIL B** IS NOT RECOMMENDED FOR ROOFS THAT ARE LIKELY TO EXPERIENCE SIGNIFICANT SNOW AND ICE UP-SLOPE FROM THE GUTTER /EDGE. REFER TO DETAILS [WBPC-1.2](#) OR [WBPC-1.3](#).

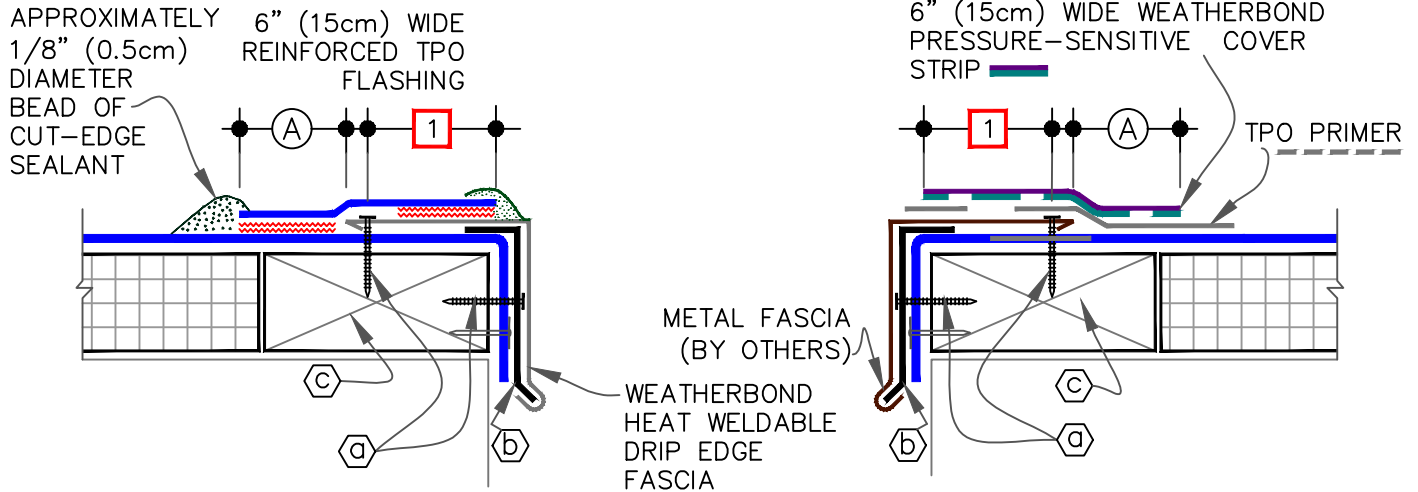

(A) WeatherBond HEAT WELDABLE DRIP EDGE FASCIA

(B) DRIP EDGE FASCIA

- (a)** M1-1/2" (3.8cm) RING SHANK NAILS
6" (15cm) O.C. MAX.
- (b)** MINIMUM 22-GAUGE CONTINUOUS CLEAT.
- (c)** WOOD NAILER (BY OTHERS)

DIMENSIONS		cm	
(A)	2"	5	MIN.
(B)	1/2"	1.5	TO
	1"	2.5	

NOTES:

1. METAL FASCIA DECK FLANGE MUST BE TOTALLY COVERED BY TPO PEEL & STICK COVER STRIP WITH MINIMUM 2" (5cm) COVERAGE PAST NAIL HEADS.
2. TO REMOVE FINISHING OILS, SCRUB METAL FLANGE WITH WEATHERED MEMBRANE CLEANER; ALLOW TO DRY PRIOR TO APPLYING TPO PRIMER.
3. WHEN METAL FASCIA BY OTHERS IS USED, FASTENER TYPE AND FASTENING FREQUENCY SHALL BE RECOMMENDED BY METAL EDGE MANUFACTURER.
4. TO ENSURE TPO PEEL & STICK COVER STRIP CONFORMS TO STEP-OFFS, HEAT COVER STRIP AT SPLICE INTERSECTIONS PRIOR TO ROLLING.

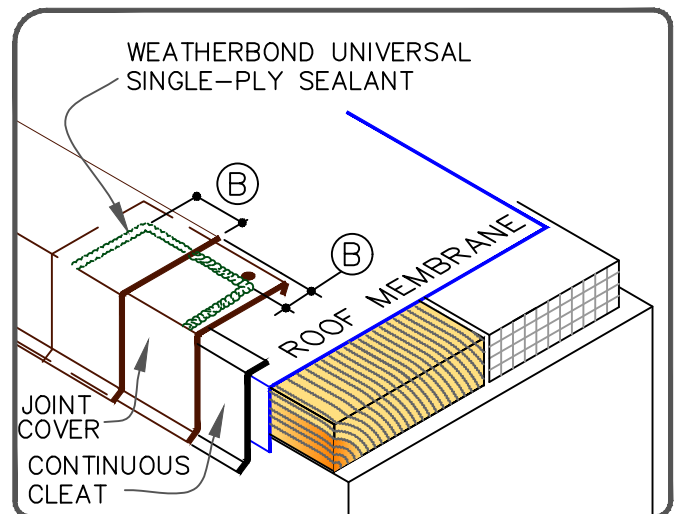

TPO DRIP EDGE FASCIA

- TPO MEMBRANE
- APPROVED SUBSTRATE
- SEE NOTE

THERMOPLASTIC ROOFING SYSTEM

WBPC-1.1

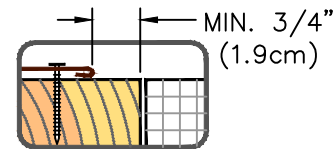
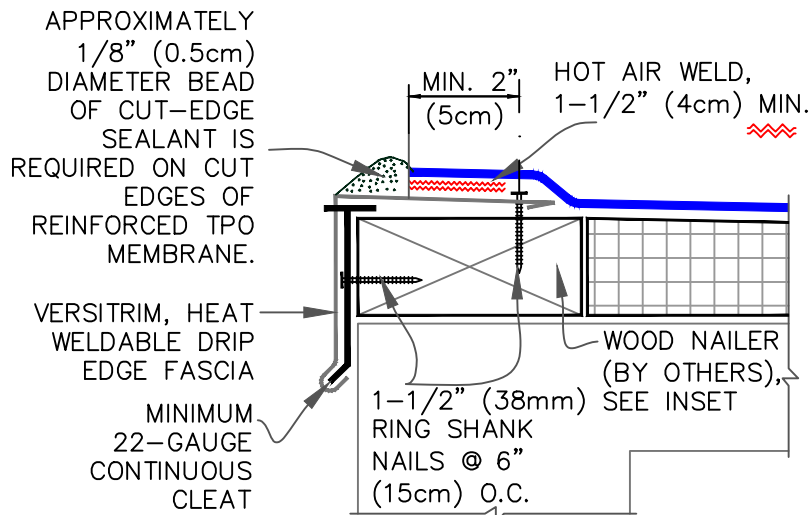

SEQUENCE:

1. 3" (7.6cm) REINFORCED MEMBRANE STRIPPING.
2. FIELD MEMBRANE.
3. TOP 6" (15.2cm) NON-REINFORCED MEMBRANE STRIPPING.

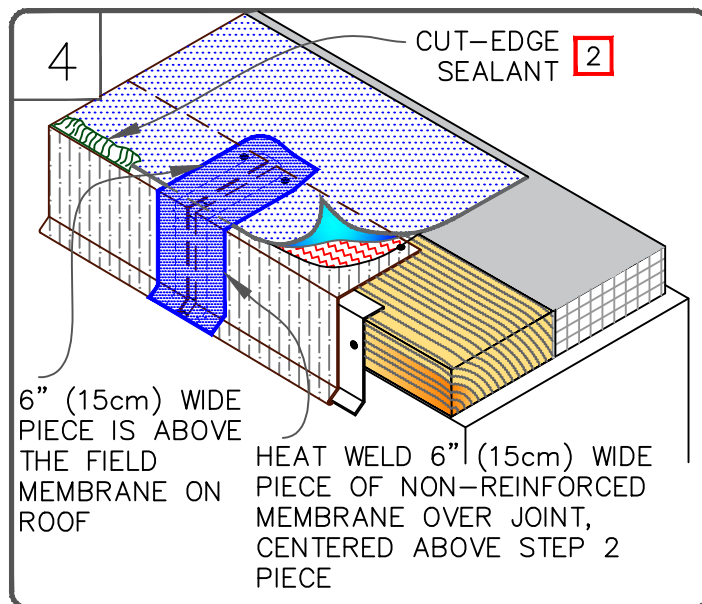
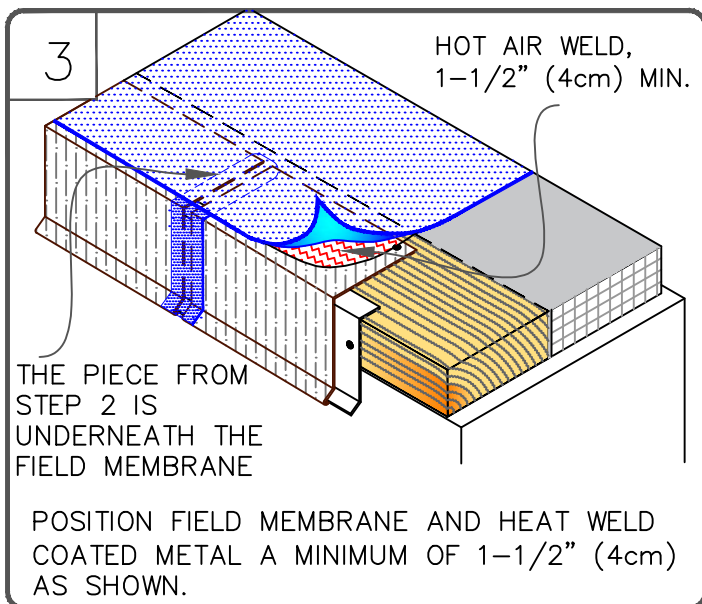
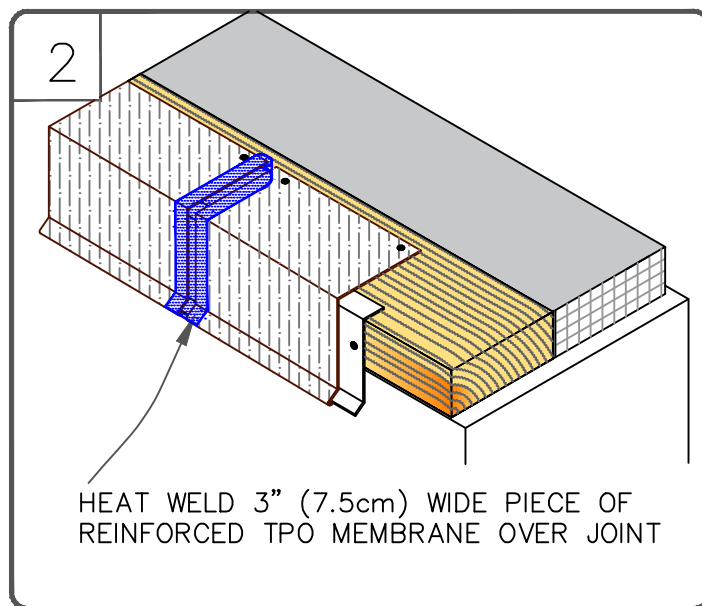
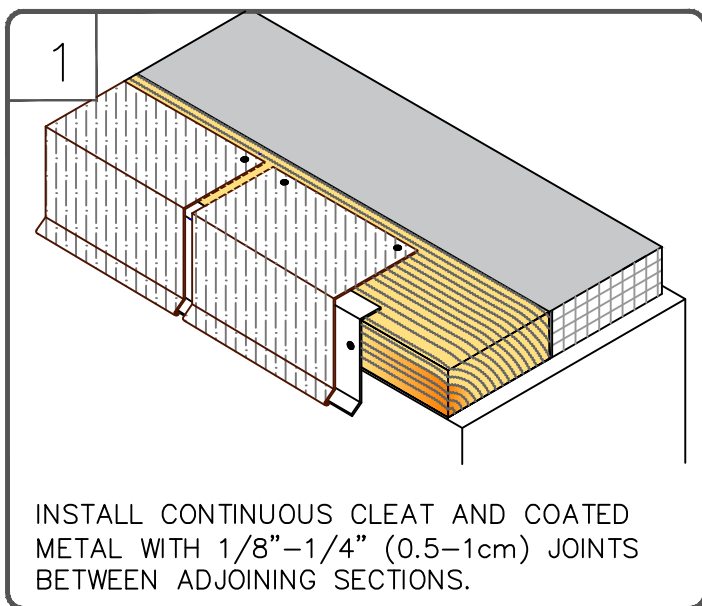

TPO WELDABLE DRIP EDGE FASCIA

- TPO MEMBRANE
- APPROVED SUBSTRATE
- SEE NOTE

THERMOPLASTIC ROOFING SYSTEM

WBPC-1.2

WEATHERBOND TERMINATION BAR FASTENED 6" (15cm) MAX. IT MUST PROVIDE A CONSTANT COMPRESSION ON WATER CUT-OFF MASTIC

EXTEND MEMBRANE SHEET TO 1/2" (1.5cm) MINIMUM BELOW THE METAL TERMINATION BAR.

GUTTER (BY OTHERS)

UNIVERSAL SINGLE-PLY SEALANT

WOOD NAILER (BY OTHERS), SEE INSET BELOW WATER CUT-OFF MASTIC XXX

±1/2" (1.3cm)

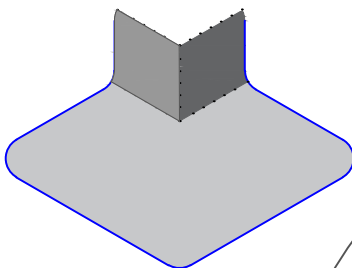

60-MIL (1.52mm) THICK TPO, UNIVERSAL CORNER CAN BE USED FOR AT TOP CORNER. CUT AS SHOWN IN DETAIL [WBPC-15.7](#)

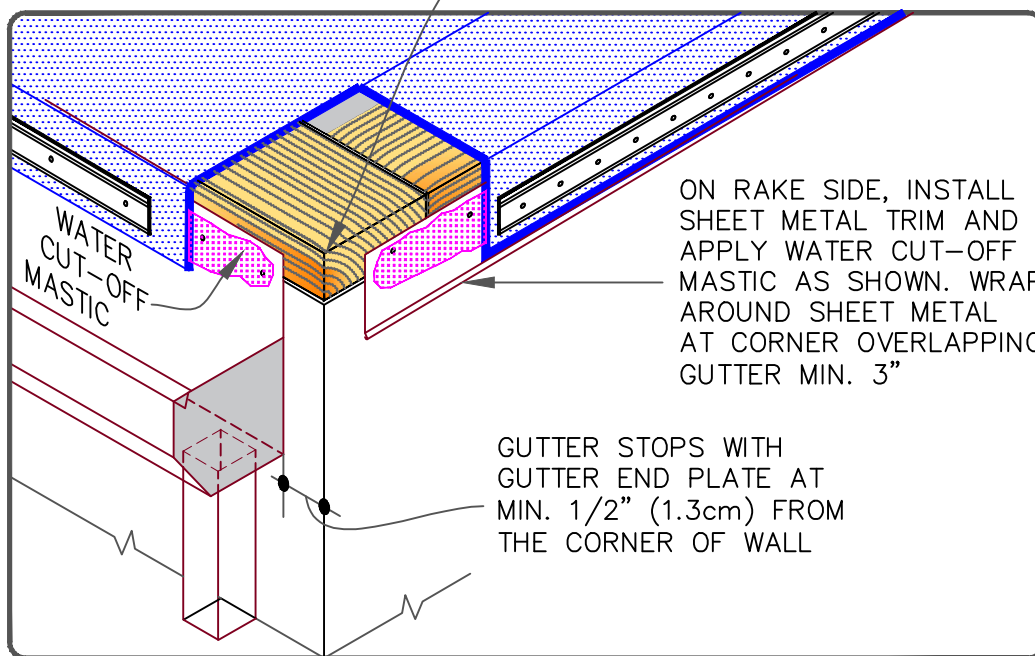

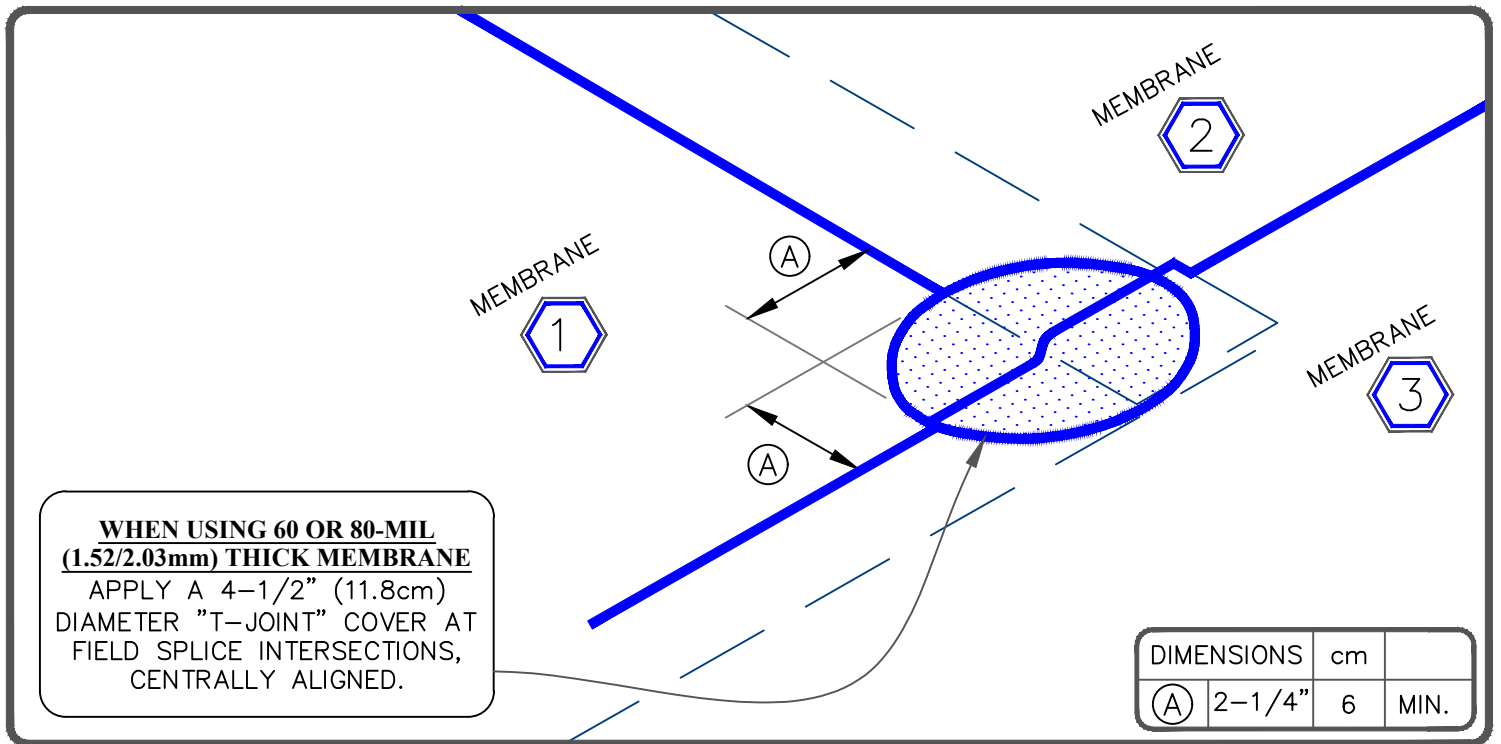
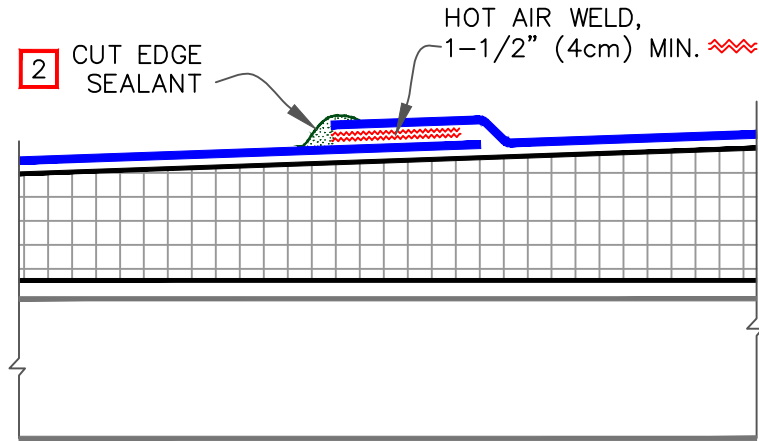

NOTES:

1. WHEN USING 60-MIL (1.52mm) MEMBRANE, MAXIMUM WARRANTY IS 20 YEARS.
2. APPROXIMATELY 1/8" (0.5cm) DIAMETER BEAD OF CUT-EDGE SEALANT IS REQUIRED ON CUT EDGES OF REINFORCED TPO MEMBRANE.



MEMBRANE SPLICE

- TPO MEMBRANE
- APPROVED SUBSTRATE
- SEE NOTE

THERMOPLASTIC ROOFING SYSTEM

WBPC-2.0

MEMBRANE SPLICE

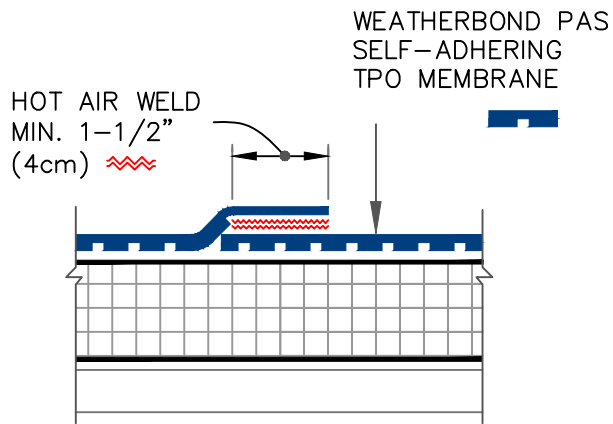

END LAP SPLICE

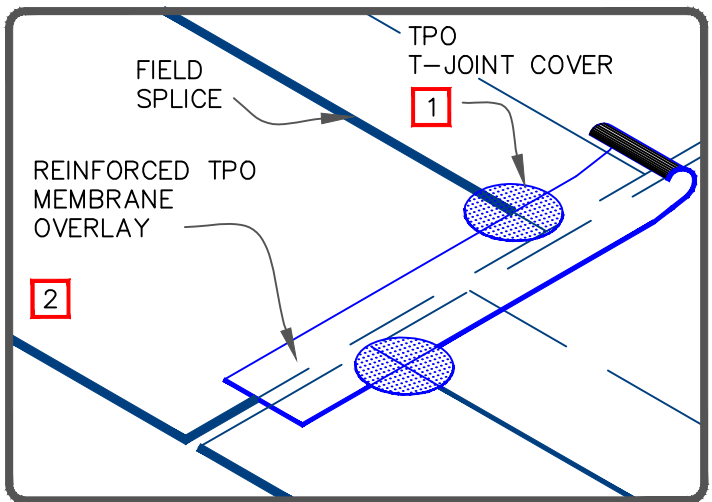
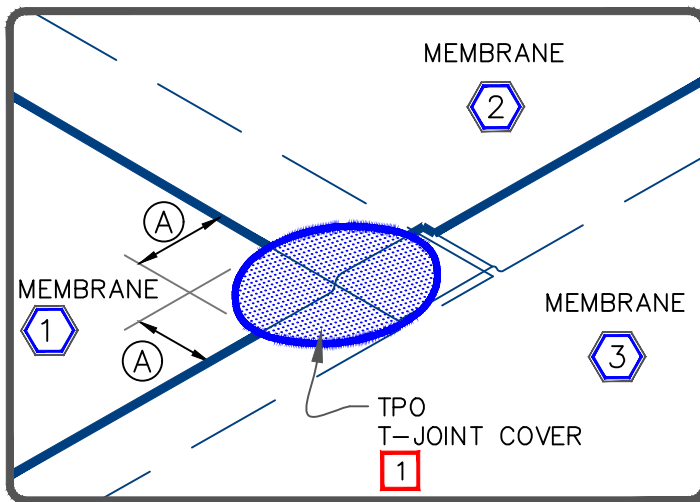
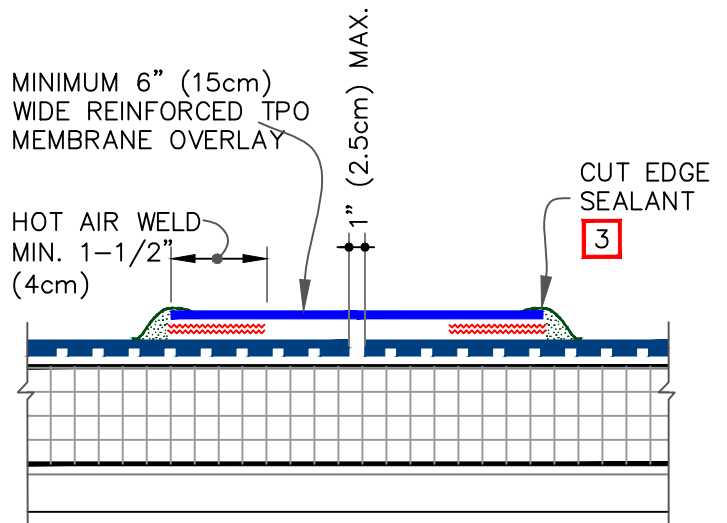

DIMENSION	cm
(A)	2-1/4" 6

NOTES:

1. WHEN USING PAS TPO MEMBRANE, 60/80 MIL (1.52/2.03mm), APPLY A 4-1/2" (11cm) DIAMETER TPO "T-JOINT" COVER AT ALL FIELD SPLICE INTERSECTIONS.
2. WHEN USING 60/80 MIL (1.52/2.03mm) TPO REINFORCED MEMBRANE OVERLAY, INTERSECTIONS BETWEEN SPLICES MUST BE OVERLAID WITH A 4-1/2" (11cm) DIAMETER TPO "T-JOINT" COVER.
3. APPROXIMATELY, 1/8" (0.5cm) DIAMETER BEAD OF CUT-EDGE SEALANT IS REQUIRED ON CUT EDGES OF REINFORCED TPO MEMBRANE.



THERMOPLASTIC MEMBRANE SPLICES

- TPO MEMBRANE
- APPROVED SUBSTRATE
- SEE NOTE

THERMOPLASTIC ROOFING SYSTEM

WBPC-2.1

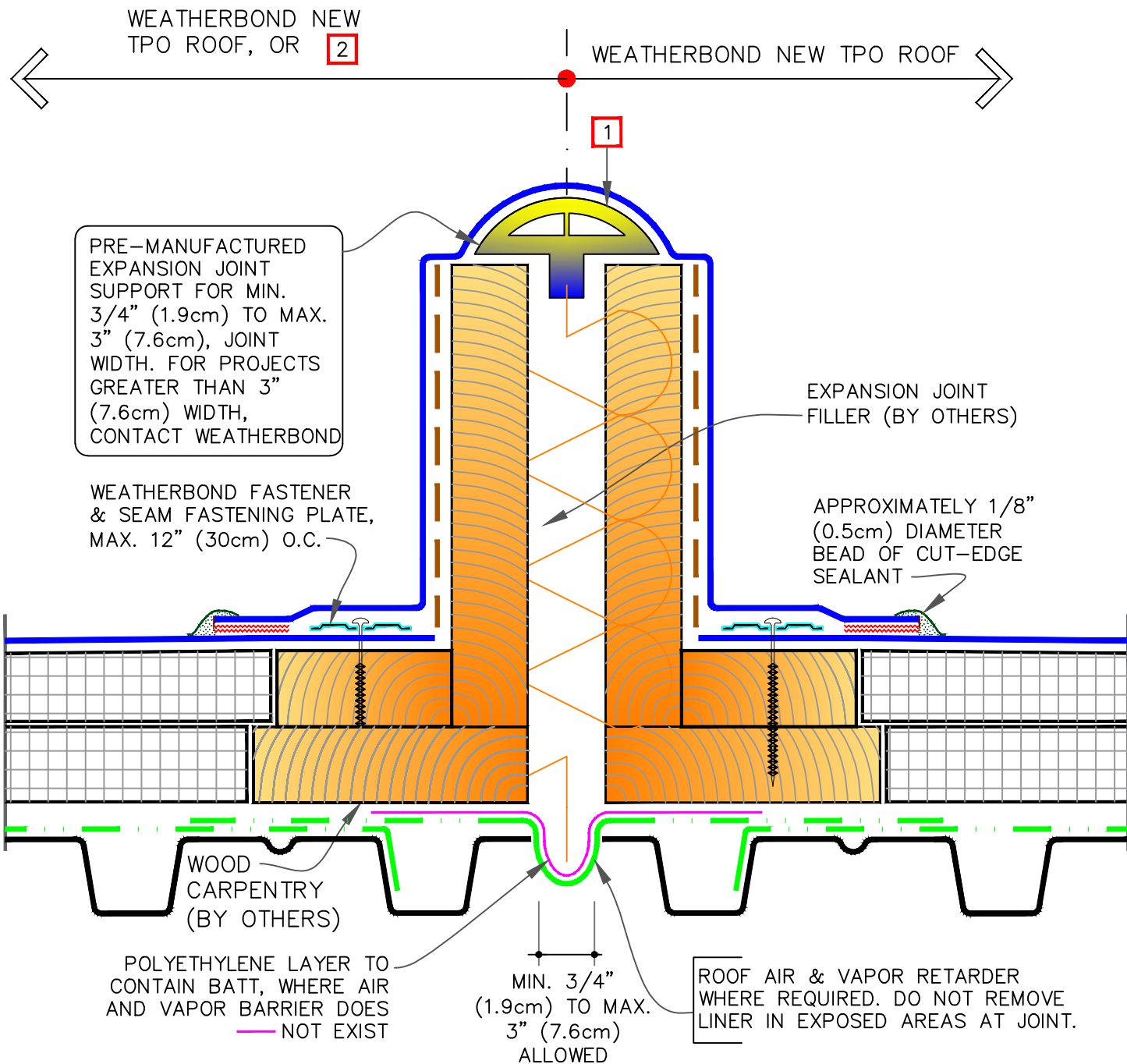

NOTES:

1. MEMBRANE FLASHING SHALL NOT BE ADHERED OVER THE EXPANSION JOINT SUPPORT.
2. IN CASE THE ROOF TYPE IS DIFFERENT, DESIGNER TO PROVIDE ROOF TYPE AND ITS CONDITION TO WEATHERBOND TO DEVELOP TIE-IN DETAIL ON THIS SIDE ACCORDINGLY.



DECK-TO-DECK EXPANSION DETAIL

- TPO MEMBRANE
- APPROVED SUBSTRATE
- 0 SEE NOTE

THERMOPLASTIC ROOFING SYSTEM
WBPC-3A.1

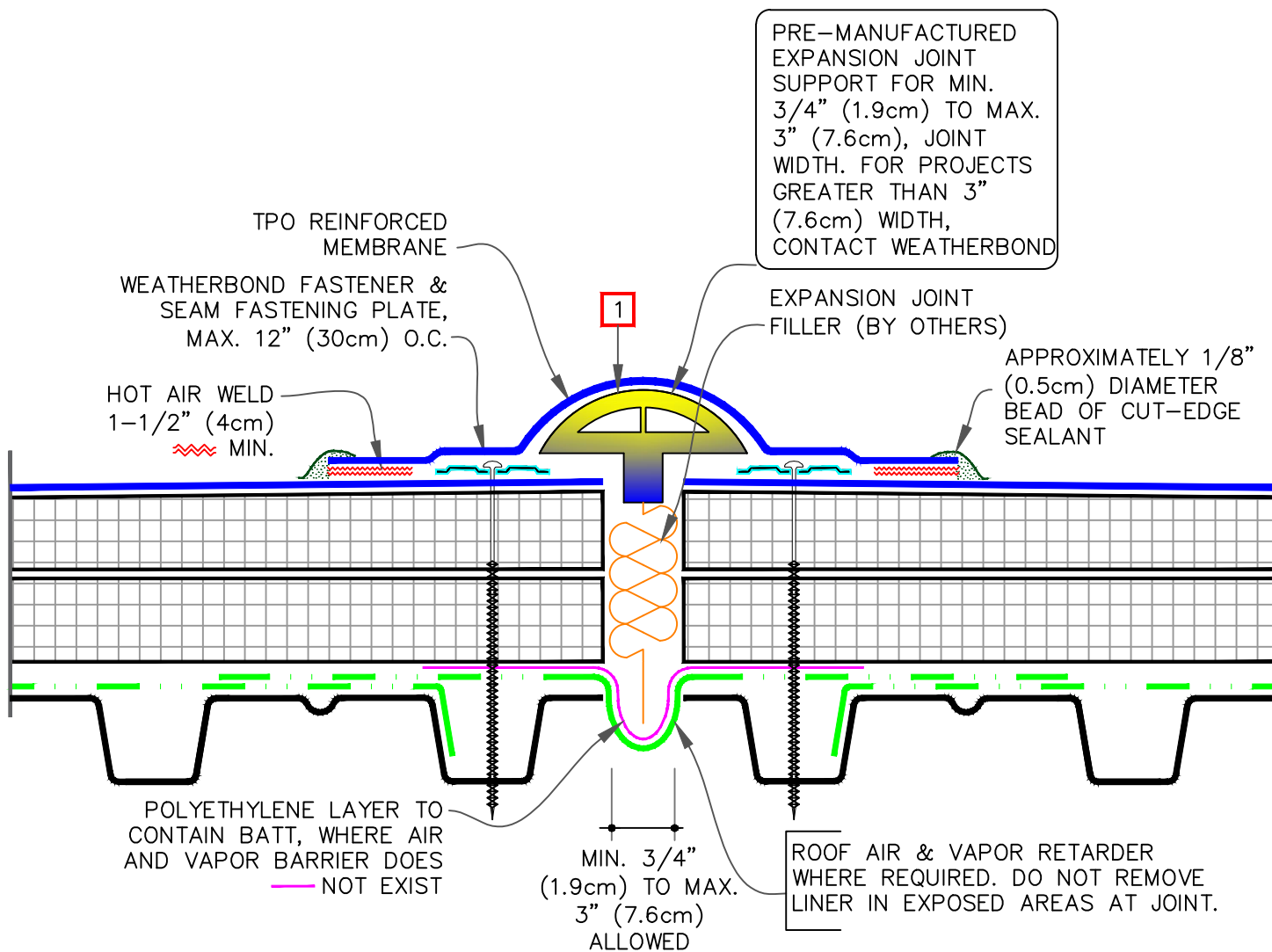

NOTES:

- MEMBRANE FLASHING SHALL NOT BE ADHERED OVER THE EXPANSION JOINT SUPPORT.
- WHEN THE EXPANSION JOINT INTERSECTS WITH A COATED METAL DRIP EDGE, THEN COATED METAL SHOULD BE GAPPED AND THE [WBPC-1.2](#) DETAIL BE FOLLOWED. DRIP EDGE BY OTHERS SHOULD ALSO BE GAPPED.

FASTENER & PRESSURE PLATE TYPES FOR DIFFERENT ROOF DECKS			
DECK TYPE	OPTION	FASTENER	PLATE
STEEL OR WOOD	A	HPWX	HPWX
	B	HPW-XL	HPW-XL
STRUCTURAL CONCRETE	A	CD-10	HPWX
	B	MP 14-10	HPWX



DECK-TO-DECK EXPANSION DETAIL

- TPO MEMBRANE
- APPROVED SUBSTRATE
- 0 SEE NOTE

THERMOPLASTIC ROOFING SYSTEM

WBPC-3.1

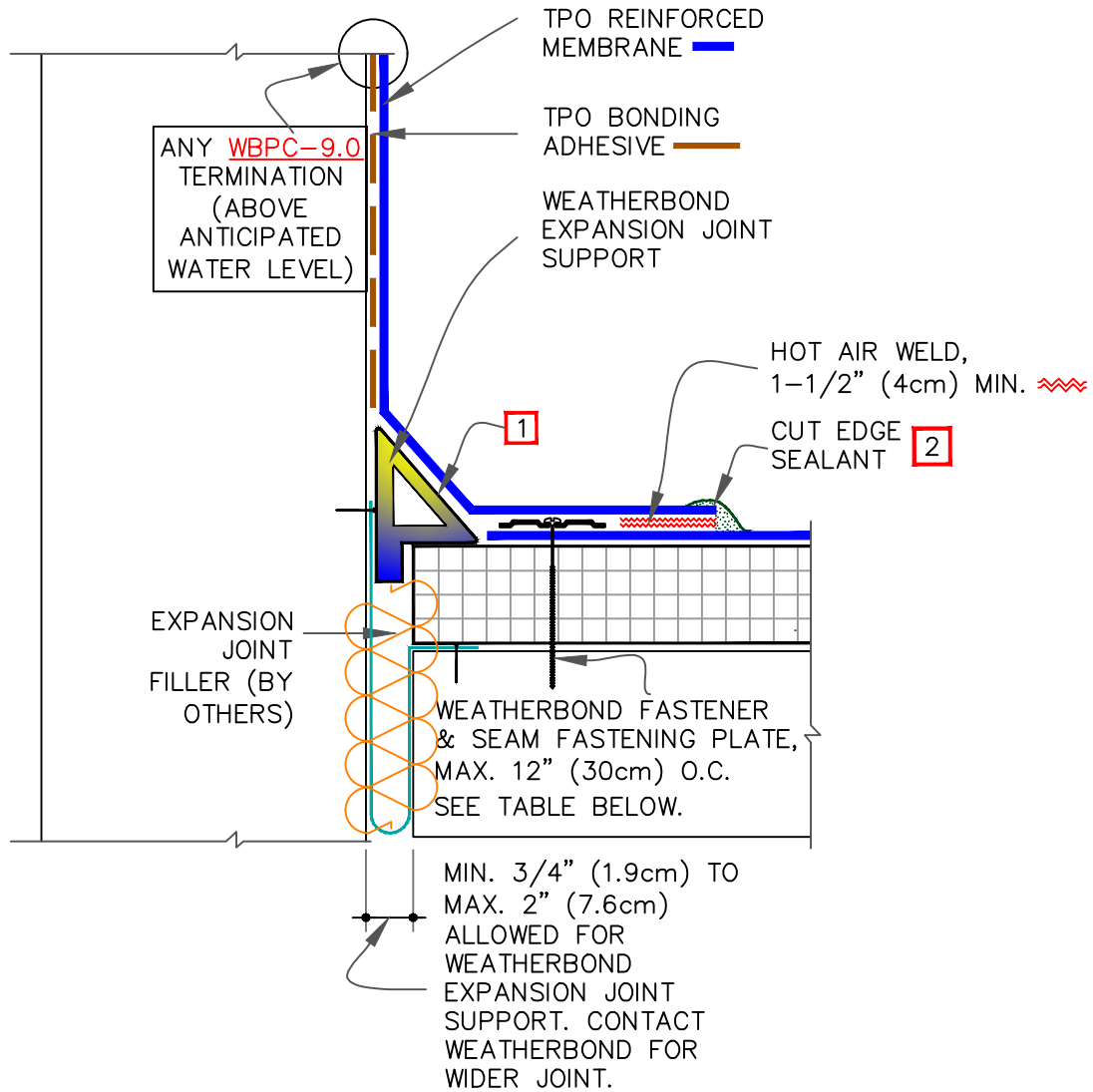

NOTES:

- MEMBRANE FLASHING SHALL NOT BE ADHERED OVER THE EXPANSION JOINT SUPPORT OR SPONGE TUBING.
- APPROXIMATELY 1/8" (0.5cm) DIAMETER BEAD OF CUT-EDGE SEALANT IS REQUIRED ON CUT EDGES OF REINFORCED TPO MEMBRANE. PLATES.

FASTENER & PRESSURE PLATE TYPES FOR DIFFERENT ROOF DECKS

DECK TYPE	OPTION	FASTENER	PLATE
STEEL OR WOOD	A	HPWX	HPWX
	B	HPW-XL	HPW-XL
STRUCTURAL CONCRETE	A	CD-10	HPWX
	B	MP 14-10	HPWX



DECK-TO-WALL EXPANSION DETAIL

— ● TPO MEMBRANE
 ● APPROVED SUBSTRATE
0 ● SEE NOTE

THERMOPLASTIC ROOFING SYSTEM

WBPC-3.2

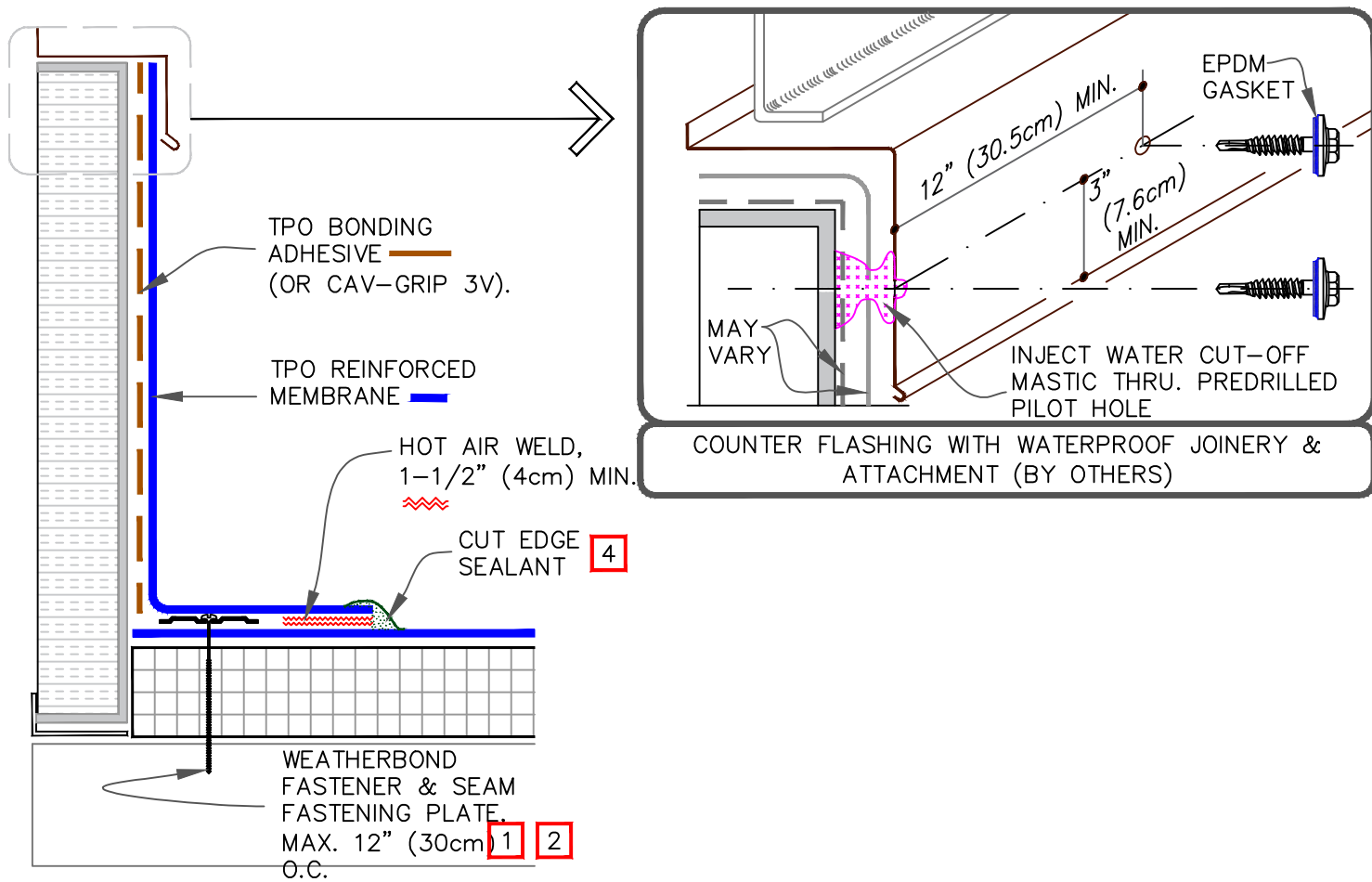

NOTES:

1. REFER TO WEATHERBOND SPECIFICATIONS FOR ACCEPTABLE WEATHERBOND FASTENERS AND PLATES.
2. MECHANICAL SECUREMENT MAY BE INSTALLED INTO THE VERTICAL SUBSTRATE.
3. WHEN USING 80 MIL (2.03mm) THICK CURB FLASHING, THE INTERSECTIONS BETWEEN SPLICES MUST OVERLAID WITH A TPO "T-JOINT" COVER.
4. APPROXIMATELY 1/8" (0.5cm) DIAMETER BEAD OF CUT-EDGE SEALANT IS REQUIRED ON CUT EDGES OF REINFORCED TPO MEMBRANE.

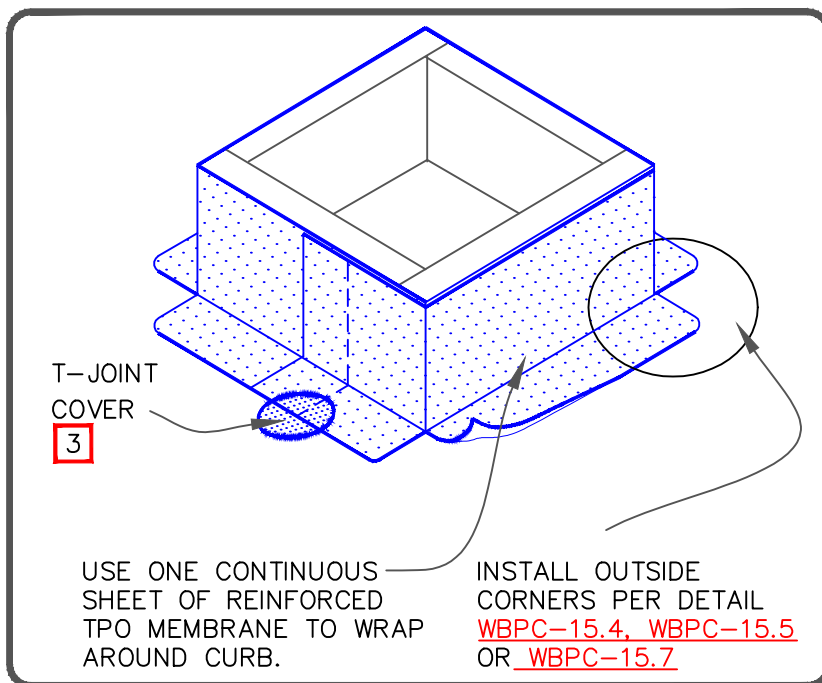

CURB FLASHING

- TPO MEMBRANE
- APPROVED SUBSTRATE
- 0 —● SEE NOTE

THERMOPLASTIC ROOFING SYSTEM

WBPC-5.1

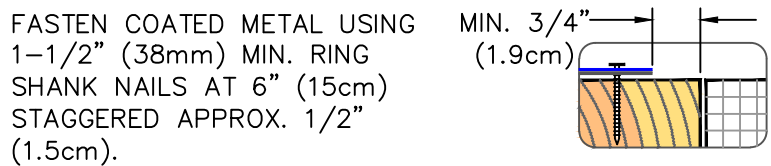
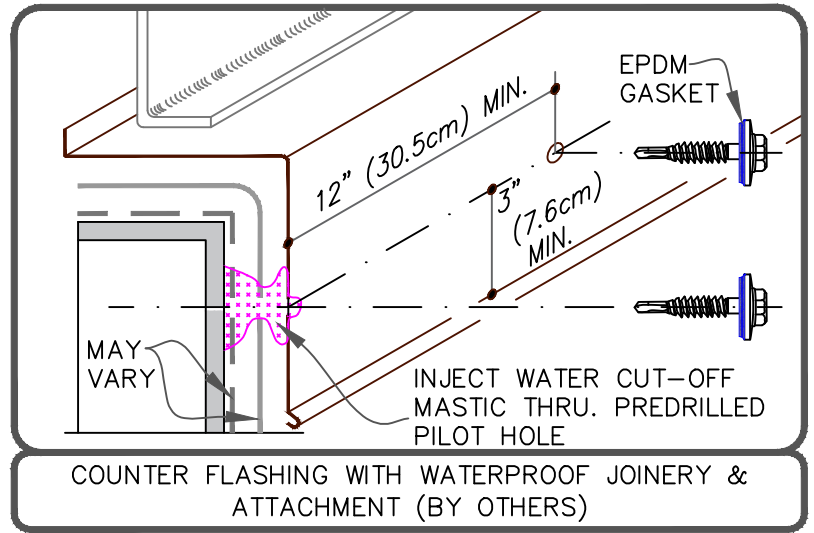
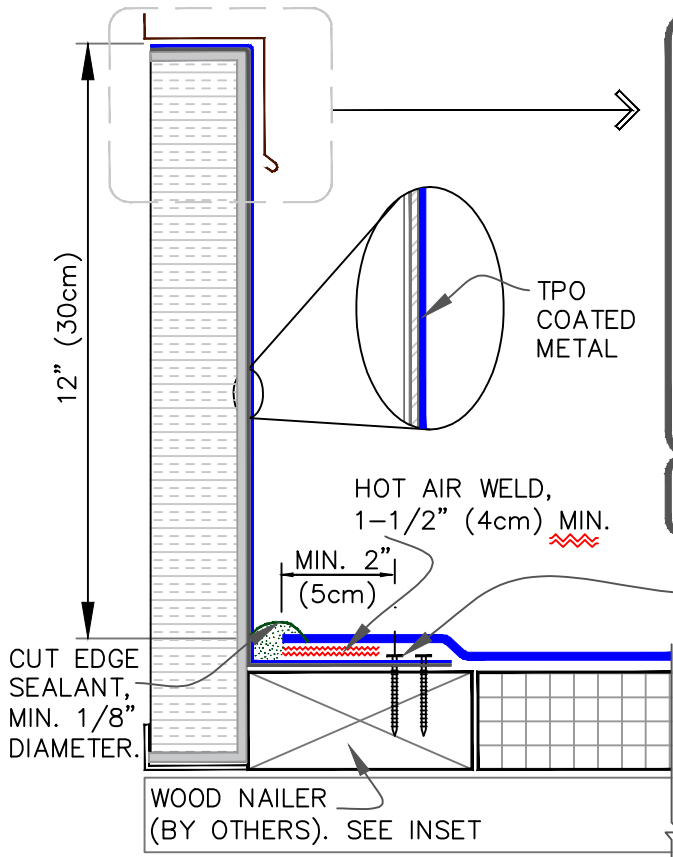

SEQUENCE:

1. 3" (7.6cm) REINFORCED MEMBRANE STRIPPING.
2. FIELD MEMBRANE.
3. TOP 6" (15.2cm) NON-REINFORCED MEMBRANE STRIPPING.

HEAT WELD 6" (15cm) WIDE PIECE OF NON-REINF. MEMBRANE OVER JOINT ON TOP OF ROOF MEMBRANE

INSTALL OUTSIDE CORNERS PER [DETAIL WBPC-15.6](#)

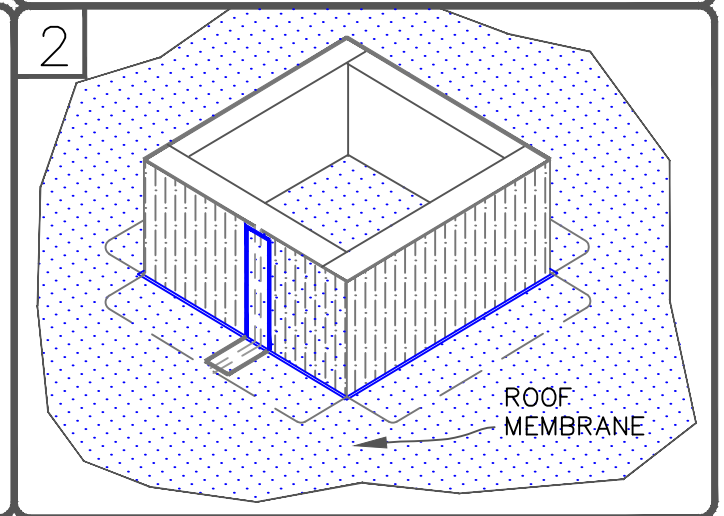
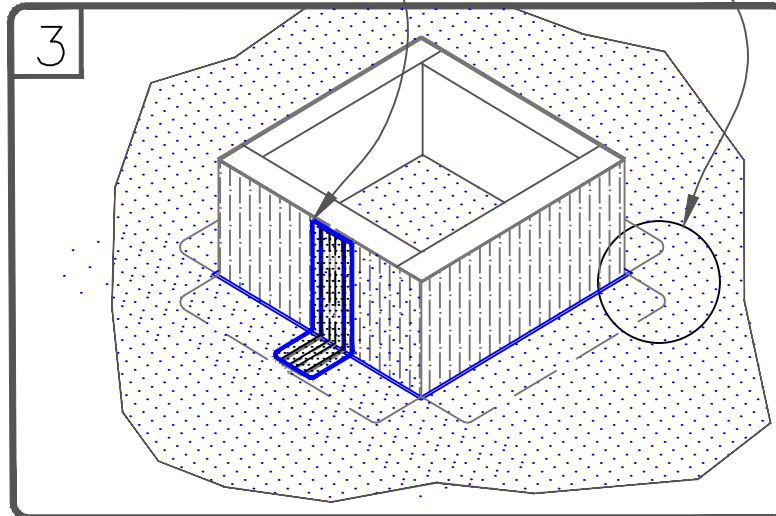
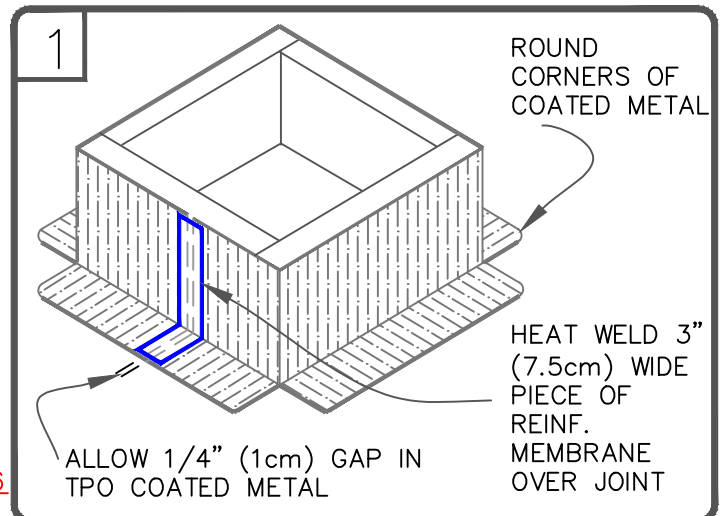

CURB FLASHING WITH TPO COATED METAL

- TPO MEMBRANE
- APPROVED SUBSTRATE
- SEE NOTE

THERMOPLASTIC ROOFING SYSTEM

WBPC-5.2

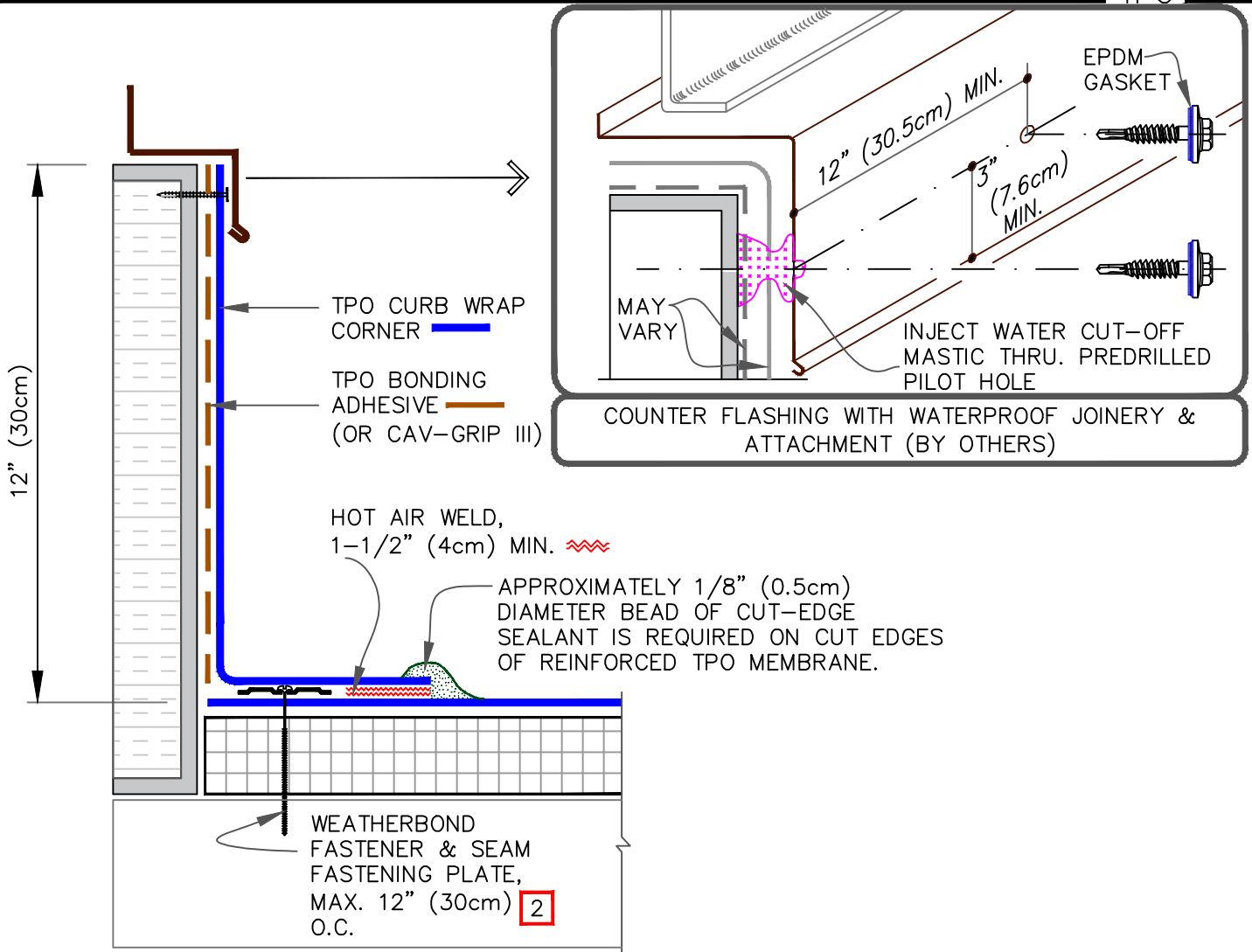

NOTES:

1. FOUR (4) CURB WRAP CORNERS WILL COMPLETELY FLASH A MAXIMUM CURB SIZE OF 3'X3' (91cmX 91cm). FOR LARGER CURBS USE THE TPO CURB WRAP CORNERS IN CONJUNCTION WITH ADDITIONAL SECTIONS OF VERSIWELD TPO MEMBRANE.
2. REFER TO WEATHERBOND SPECIFICATIONS FOR ACCEPTABLE WEATHERBOND FASTENERS AND PLATES.
3. CUSTOM SIZES ARE AVAILABLE FOR CURB FLASHING HEIGHTS GREATER THAN 12" (30cm).

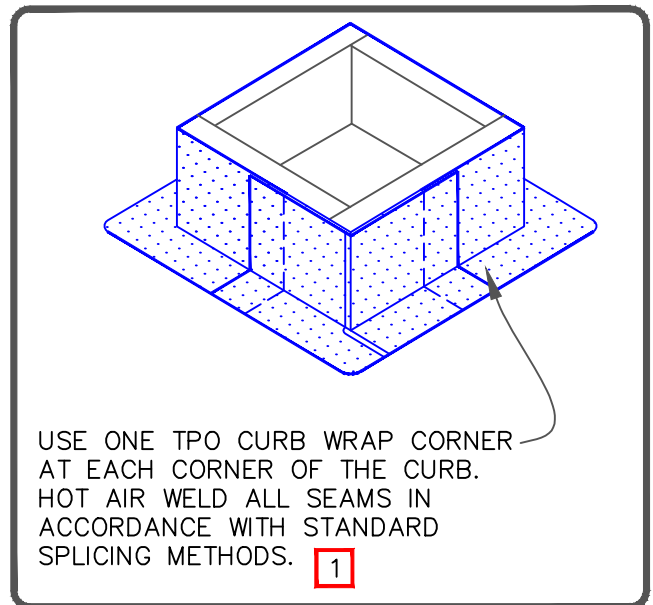

CURB FLASHING WITH UNIVERSAL TPO CURB WRAP CORNERS

—●— TPO MEMBRANE

—●— APPROVED SUBSTRATE

0 —●— SEE NOTE

THERMOPLASTIC ROOFING SYSTEM

WBPC-5.3

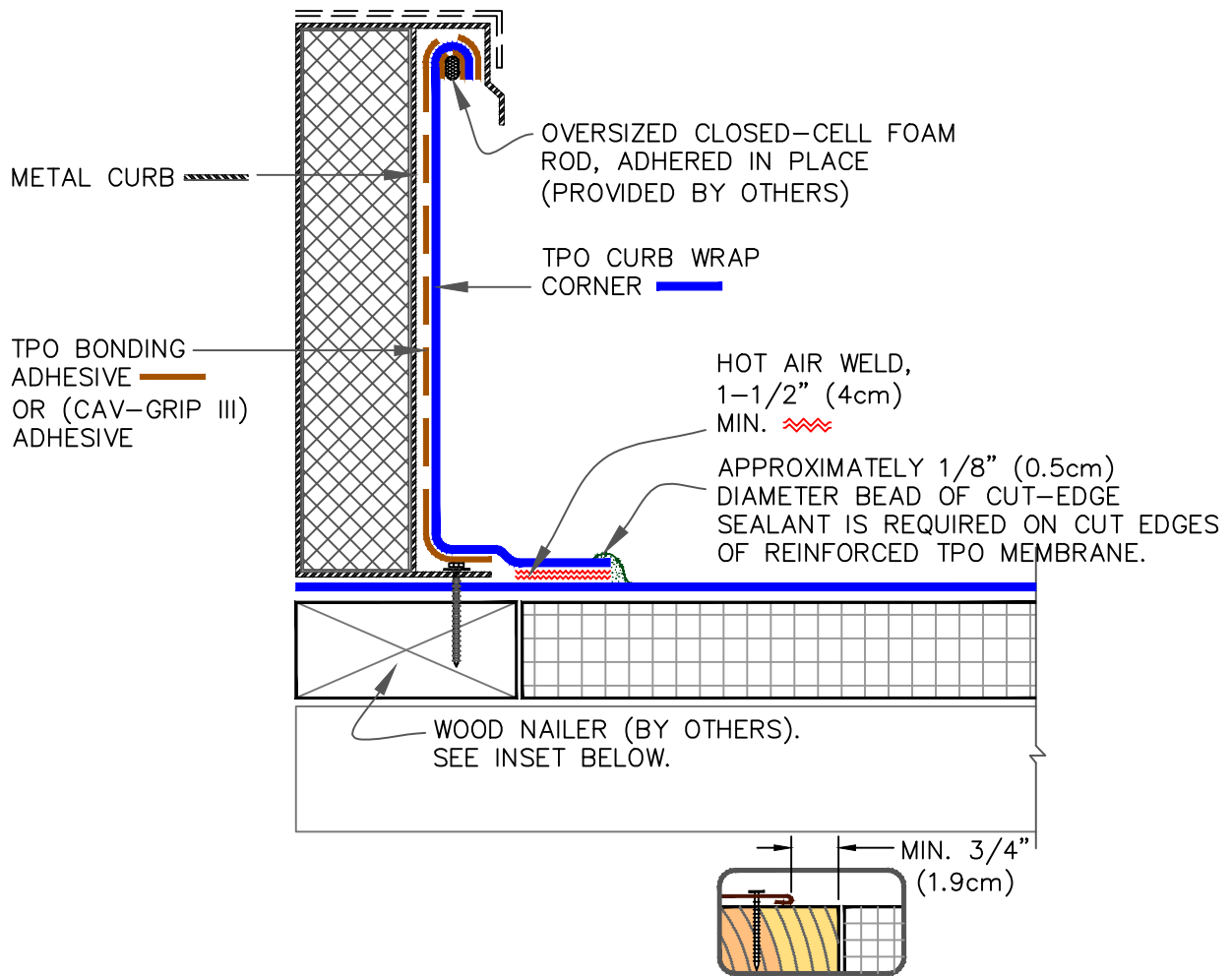

NOTES:

1. FOUR (4) CURB WRAP CORNERS WILL COMPLETELY FLASH A MAXIMUM CURB SIZE OF 3'X3' (90cmX 90cm). FOR LARGER CURBS USE THE TPO CURB WRAP CORNERS IN CONJUNCTION WITH ADDITIONAL SECTIONS OF WEATHERBOND TPO.
2. IF CURB WRAP CORNER IS NOT USED, THEN USE DETAIL [WBPC-15.7](#) FOR OUTSIDE CORNERS.
3. REFER TO WEATHERBOND SPECIFICATIONS FOR ACCEPTABLE WEATHERBOND FASTENERS AND PLATES.
4. CUSTOM SIZES ARE AVAILABLE FOR CURB FLASHING HEIGHTS GREATER THAN 12" (30cm).

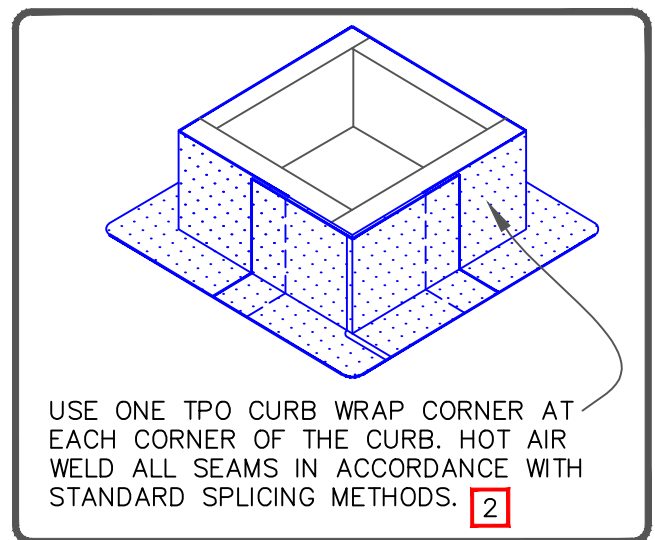

SELF-FLASHING CURB

	● TPO MEMBRANE
	● APPROVED SUBSTRATE
0	● SEE NOTE

THERMOPLASTIC ROOFING SYSTEM

WBPC-5.4

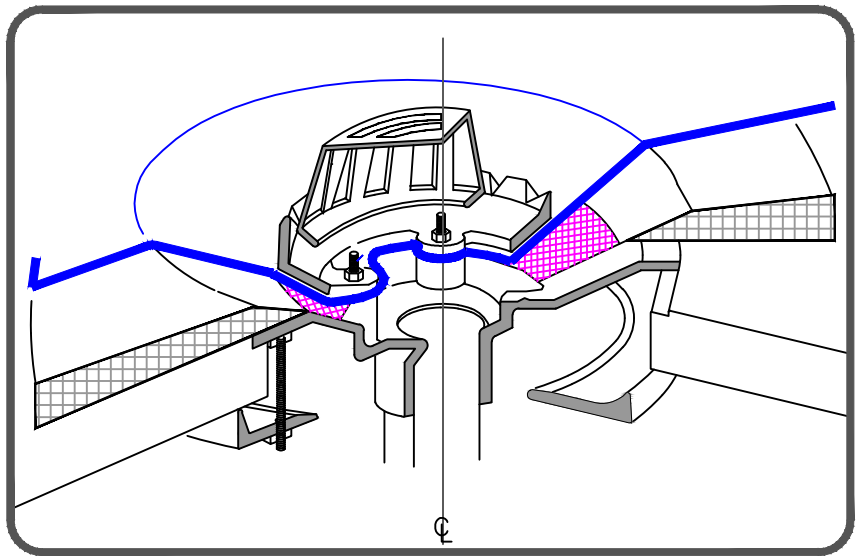
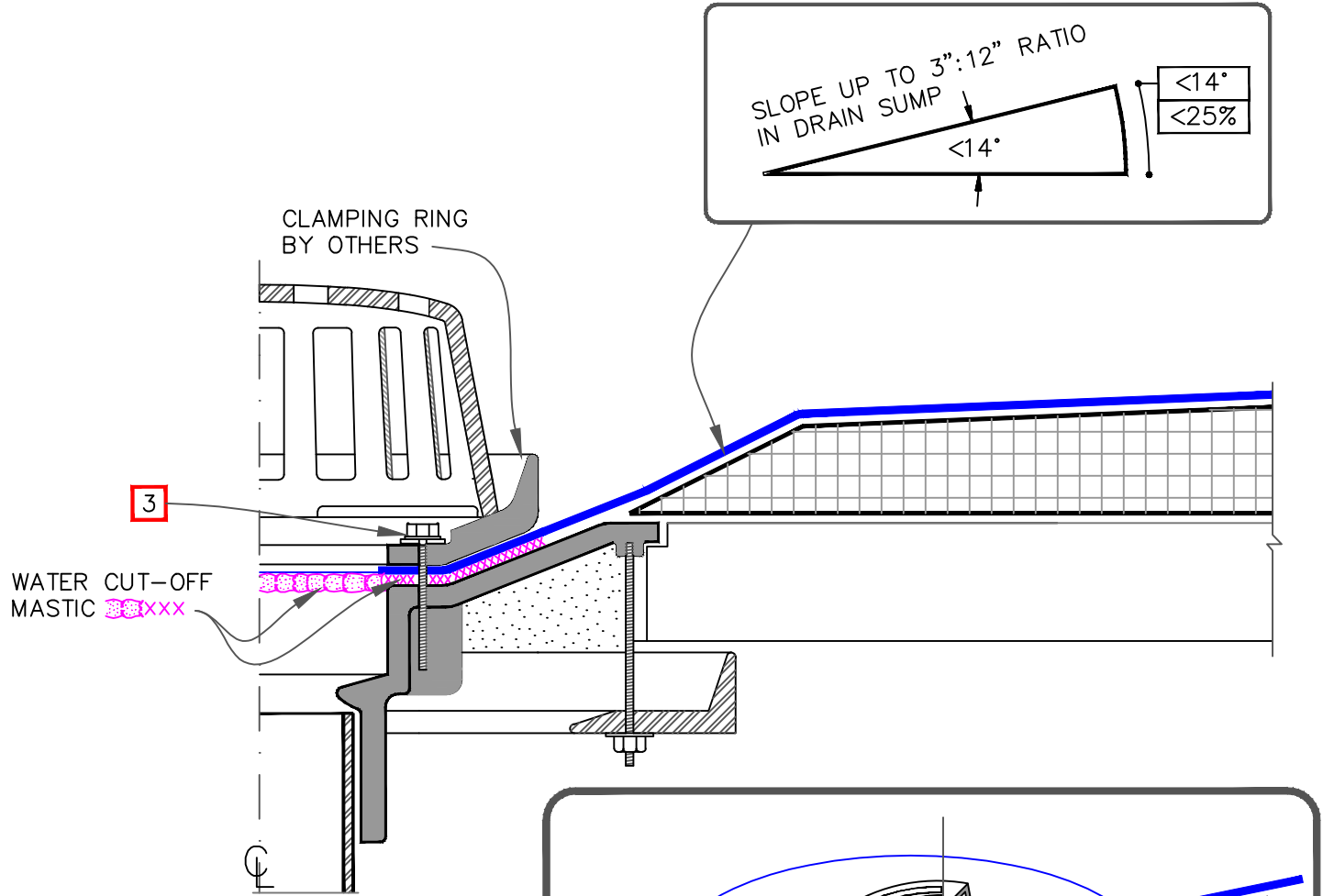

NOTES:

1. ROOF DRAIN SIZE AND NUMBER OF DRAINS SHALL BE IN ACCORDANCE WITH THE LOCAL CODES.
2. THE HOLE IN THE MEMBRANE SHALL EXCEED THE DIAMETER OF THE DRAIN PIPE, BUT SHALL BE NO LESS THAN 1/2" (1.5cm) FROM THE ATTACHMENT POINTS OF THE DRAIN CLAMPING RING.
3. ALL BOLTS OR CLAMPS MUST BE IN PLACE TO PROVIDE CONSTANT COMPRESSION ON WATER CUT-OFF MASTIC.
4. REMOVE EXISTING LEAD, FLASHING MATERIAL & ENSURE THE DRAIN RING IS COMPLETELY CLEAN DOWN TO BARE METAL.

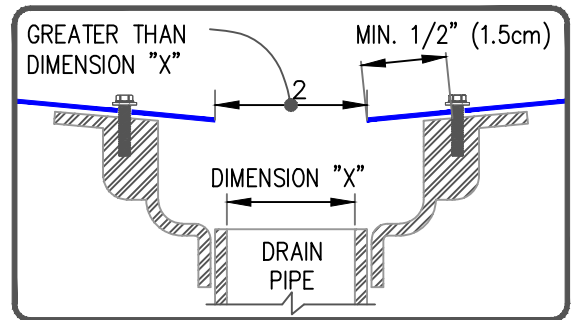

ROOF DRAIN (DRAIN SUMP UP TO 3 INCHES TO 1 HORIZONTAL FOOT)

- TPO MEMBRANE
- APPROVED SUBSTRATE
- SEE NOTE

THERMOPLASTIC ROOFING SYSTEM

WBPC-6.1

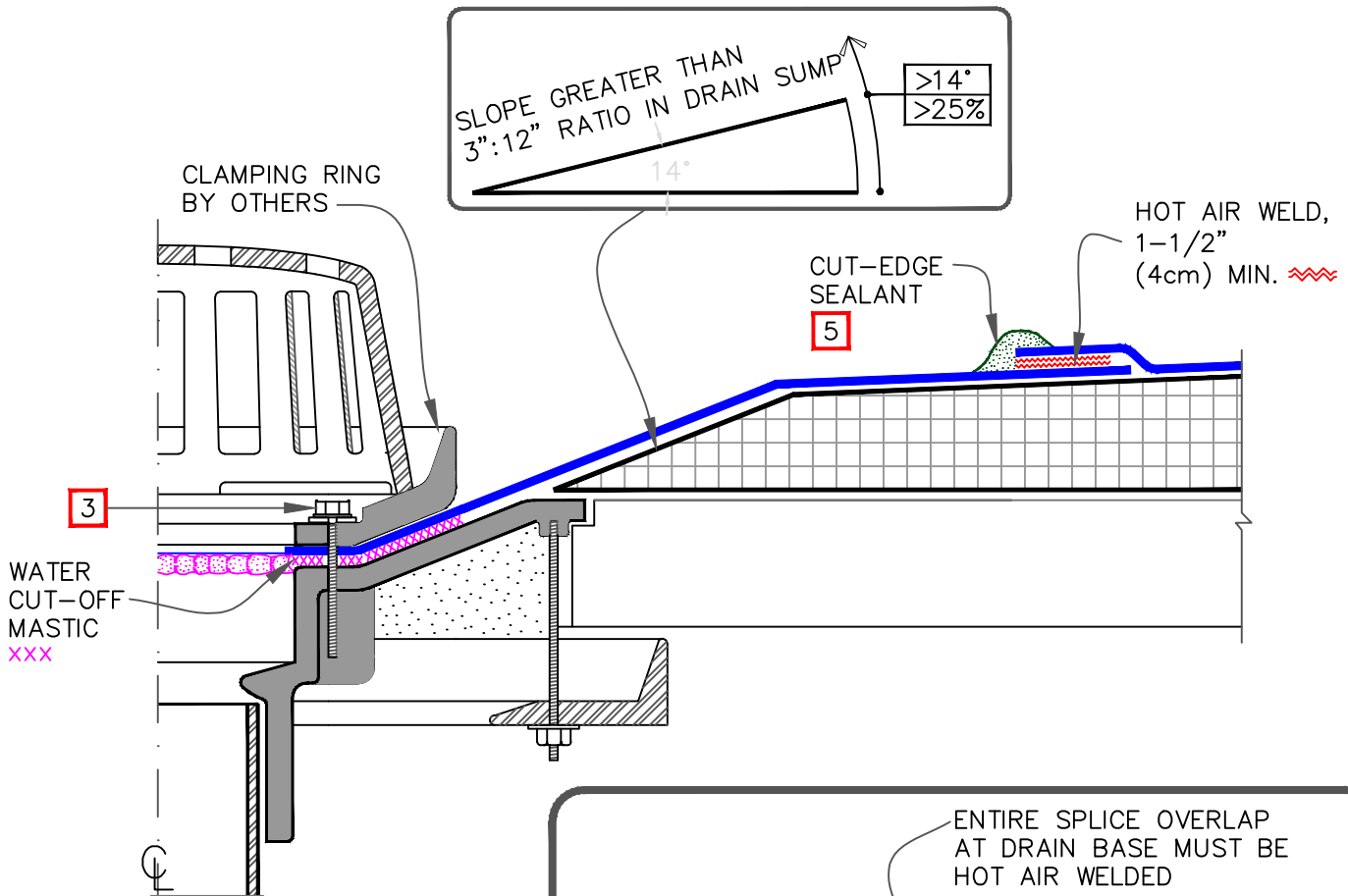

NOTES:

1. ROOF DRAIN SIZE AND NUMBER OF DRAINS SHALL BE IN ACCORDANCE WITH THE LOCAL CODES.
2. THE HOLE IN THE MEMBRANE SHALL EXCEED THE DIAMETER OF THE DRAIN PIPE, BUT SHALL BE NO LESS THAN 1/2" (1.5cm) FROM THE ATTACHMENT POINTS OF THE DRAIN CLAMPING RING.
3. ALL BOLTS OR CLAMPS MUST BE IN PLACE TO PROVIDE CONSTANT COMPRESSION ON WATER CUT-OFF MASTIC.
4. REMOVE EXISTING LEAD, FLASHING MATERIAL & ENSURE THE DRAIN RING IS COMPLETELY CLEAN DOWN TO BARE METAL.
5. APPROXIMATELY 1/8" (0.5cm) DIAMETER BEAD OF CUT-EDGE SEALANT IS REQUIRED ON CUT EDGES OF REINFORCED TPO MEMBRANE.

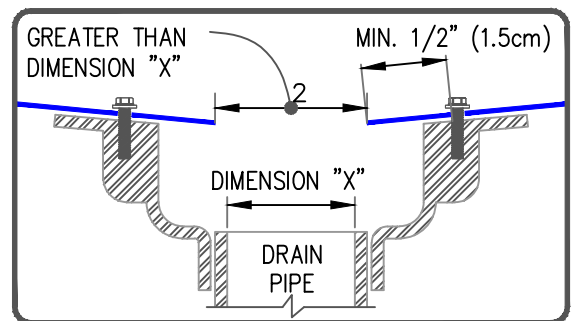
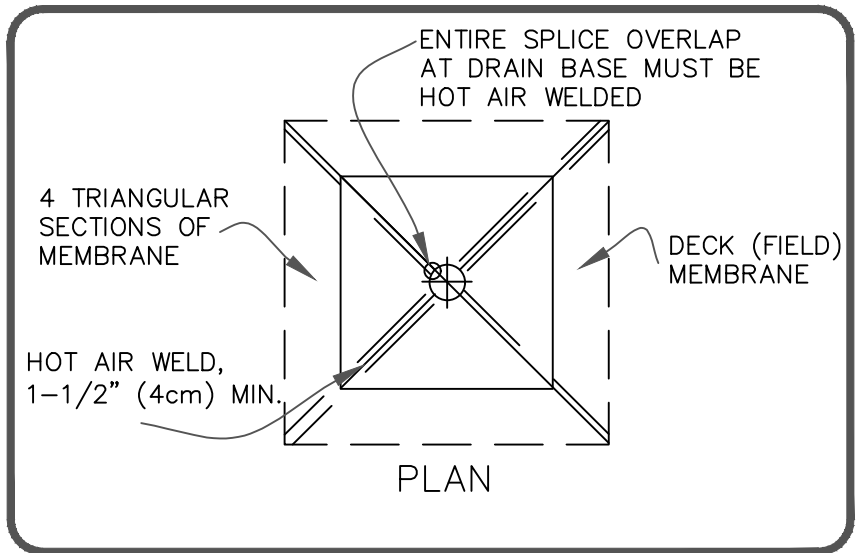

ROOF DRAIN (DRAIN SUMP GREATER THAN 3" TO 1 HORIZONTAL FOOT) OPTION 1

—●— TPO MEMBRANE

—●— APPROVED SUBSTRATE

0 —●— SEE NOTE

THERMOPLASTIC ROOFING SYSTEM

WBPC-6.2

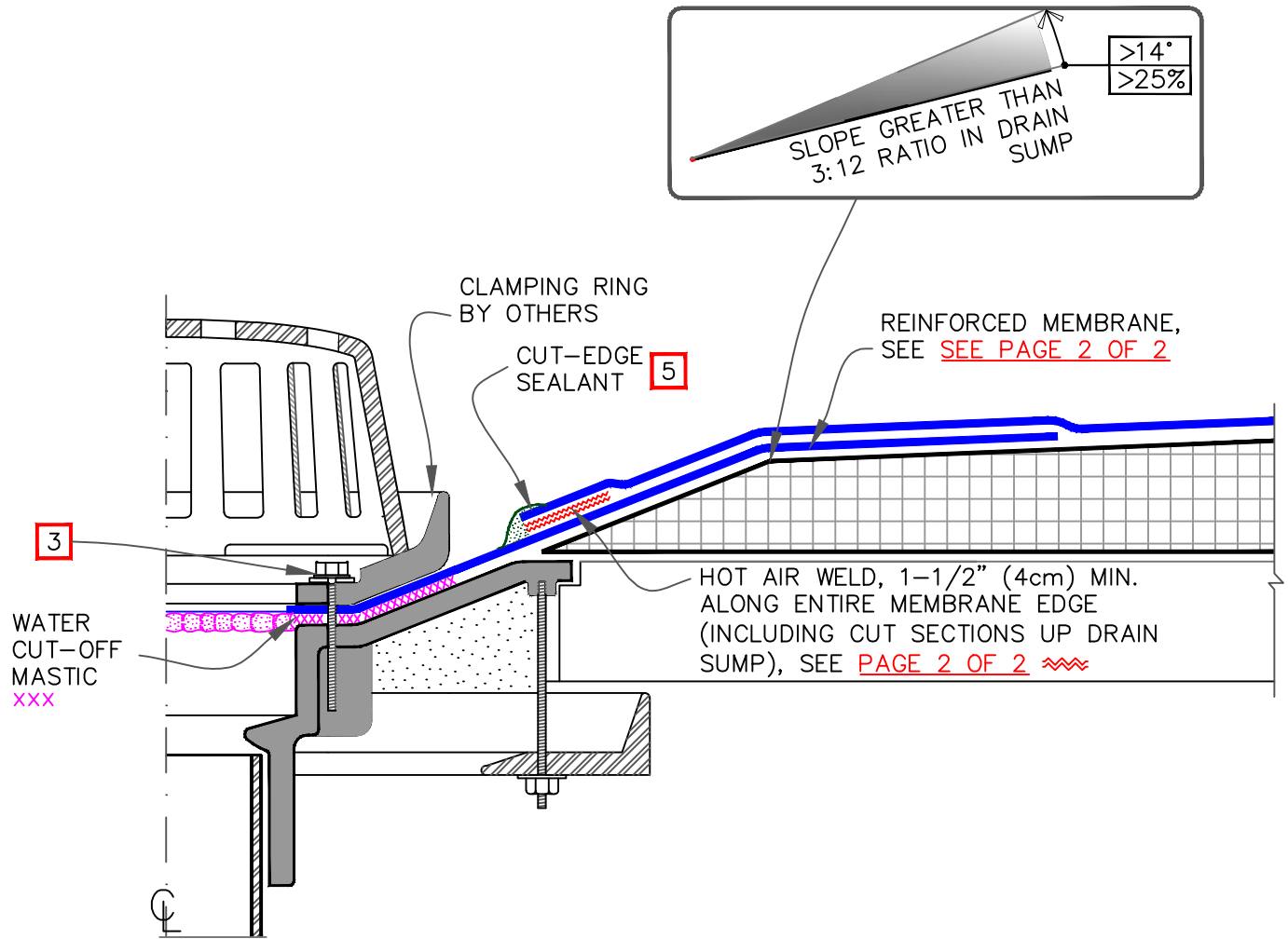

NOTES:

1. ROOF DRAIN SIZE AND NUMBER OF DRAINS SHALL BE IN ACCORDANCE WITH THE LOCAL CODES.
2. THE HOLE IN THE MEMBRANE SHALL EXCEED THE DIAMETER OF THE DRAIN PIPE, BUT SHALL BE NO LESS THAN 1/2" (1.5cm) FROM THE ATTACHMENT POINTS OF THE DRAIN CLAMPING RING.
3. ALL BOLTS OR CLAMPS MUST BE IN PLACE TO PROVIDE CONSTANT COMPRESSION ON WATER CUT-OFF MASTIC.
4. REMOVE EXISTING LEAD, FLASHING MATERIAL & ENSURE THE DRAIN RING IS COMPLETELY CLEAN DOWN TO BARE METAL.
5. APPROXIMATELY 1/8" (0.5cm) DIAMETER BEAD OF CUT-EDGE SEALANT IS REQUIRED ON CUT EDGES OF REINFORCED TPO MEMBRANE.

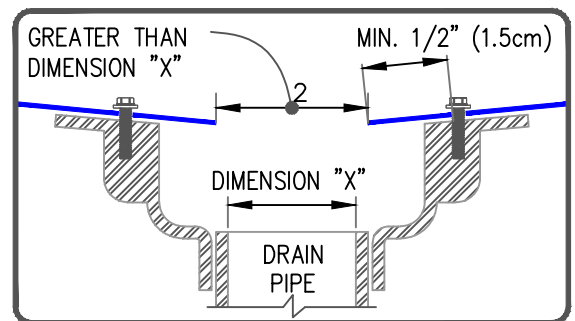

ROOF DRAIN (DRAIN SUMP GREATER THAN 3" TO 1 HORIZONTAL FOOT) OPTION 2, PAGE 1 OF 2

- ● TPO MEMBRANE
- APPROVED SUBSTRATE
- 0 ● SEE NOTE

THERMOPLASTIC ROOFING SYSTEM

WBPC-6.3

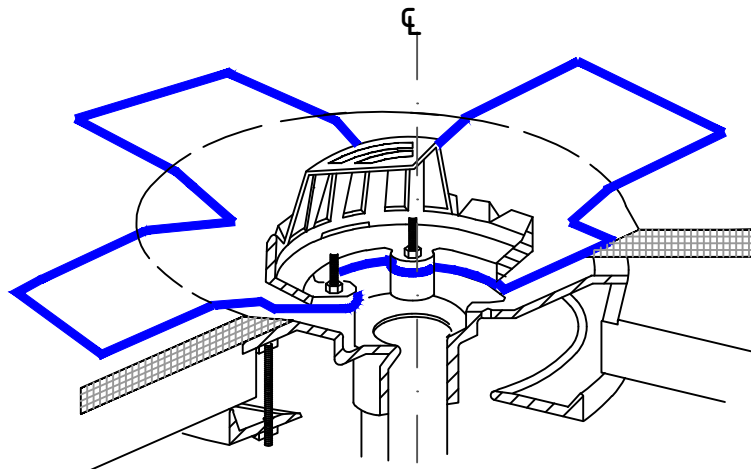
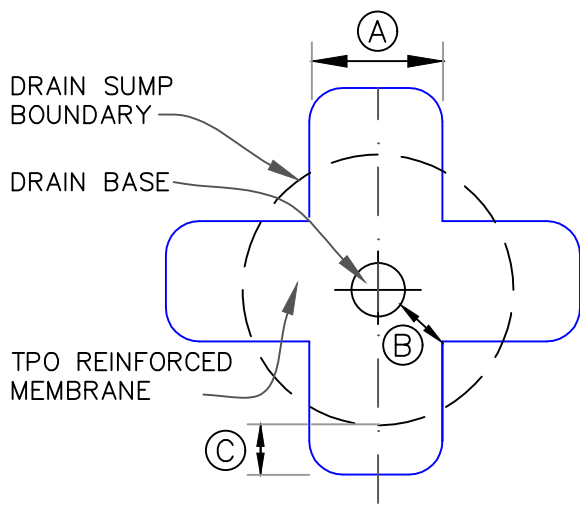
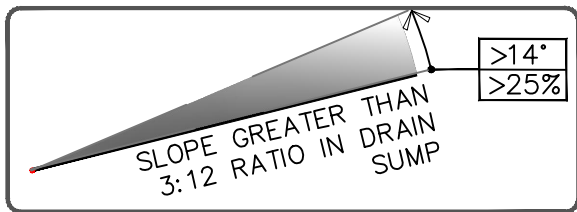

EXTEND TPO MEMBRANE ONTO MEMBRANE SECTION POSITIONED AT DRAIN SUMP AND CUT AS SHOWN TO LAY FLAT IN SUMP. HOT AIR WELD A MINIMUM OF 1-1/2" (4cm) COMPLETELY SURROUNDING AREA.

CUT SECTION OF TPO REINFORCED MEMBRANE AS SHOWN AND POSITION INTO DRAIN SUMP. EXTEND MEMBRANE OUT OF DRAIN SUMP APPROXIMATELY 6" (15cm) (ROUND CORNERS).

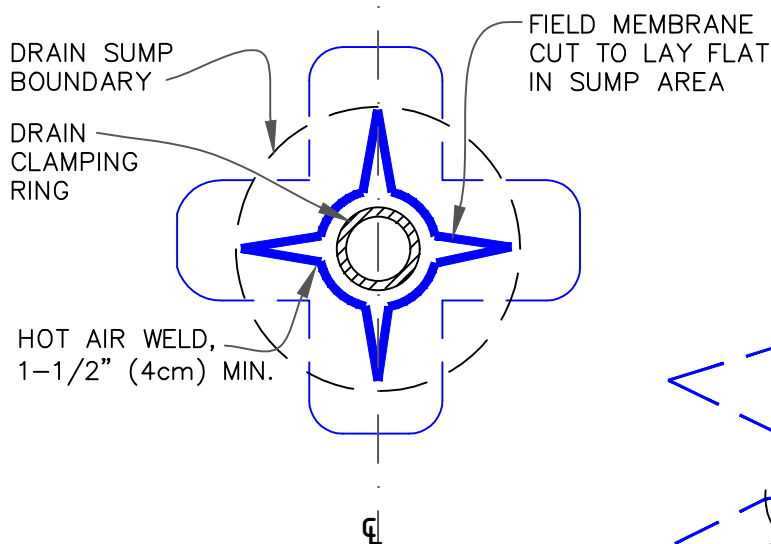

DIMENSIONS		cm	
(A)	12"	30	MIN.
(B)	6"	15	MIN.
(C)	6"	15	APPROX.
(D)	3"	7.5	MIN.

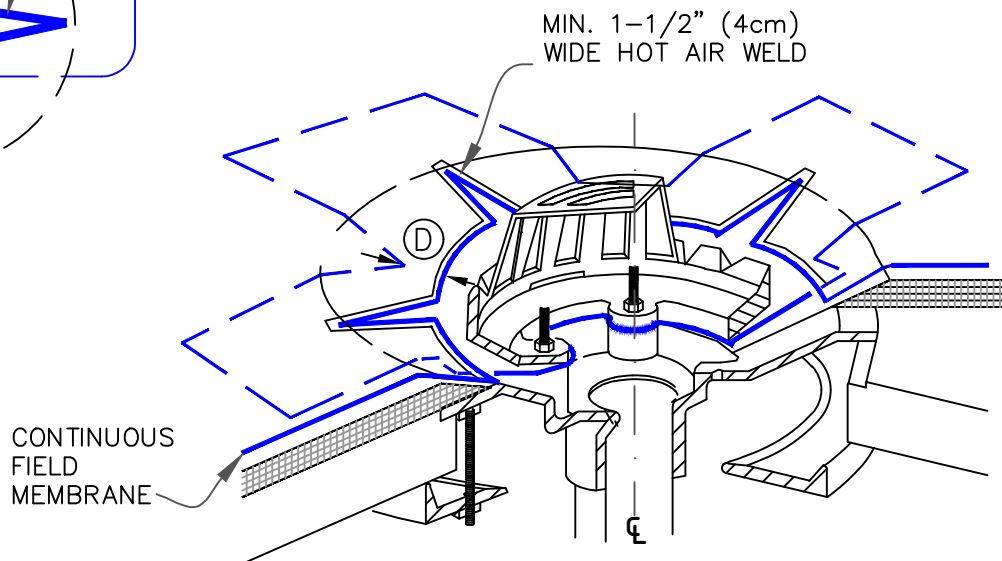

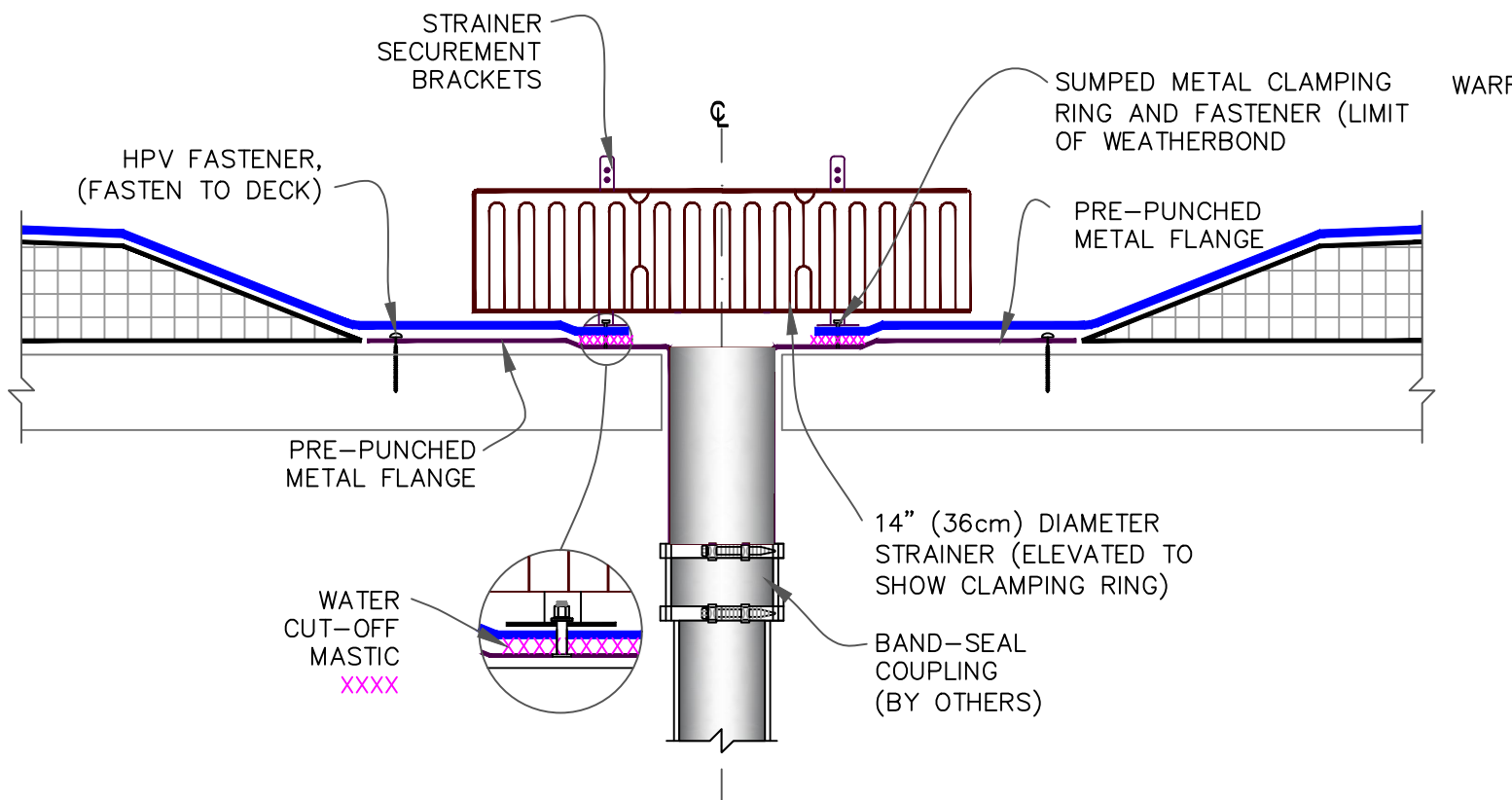

NOTES:

1. ROOF DRAIN SIZE AND NUMBER OF DRAINS SHALL BE IN ACCORDANCE WITH THE LOCAL CODES.
2. ALL BOLTS OR CLAMPS MUST BE IN PLACE TO PROVIDE CONSTANT COMPRESSION ON WATER CUT-OFF MASTIC.
3. FIELD SPLICES MUST BE LOCATED AT LEAST 6" (15cm) OUTSIDE THE DRAIN SUMP.
4. INSULATION TAPER SHALL NOT BE GREATER THAN 6" (15cm) IN 12" (30cm) HORIZONTAL.

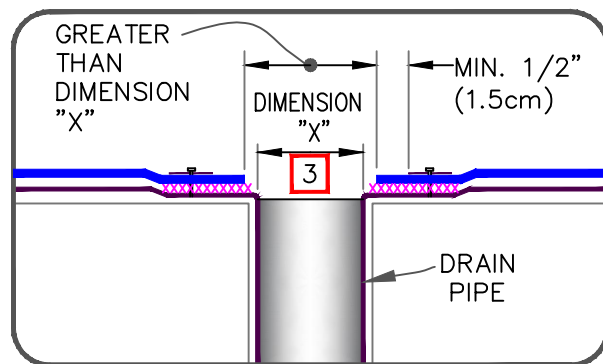

ADD-ON DRAIN

—● TPO MEMBRANE
 APPROVED SUBSTRATE
0 SEE NOTE

THERMOPLASTIC ROOFING SYSTEM
WBPC-6.4

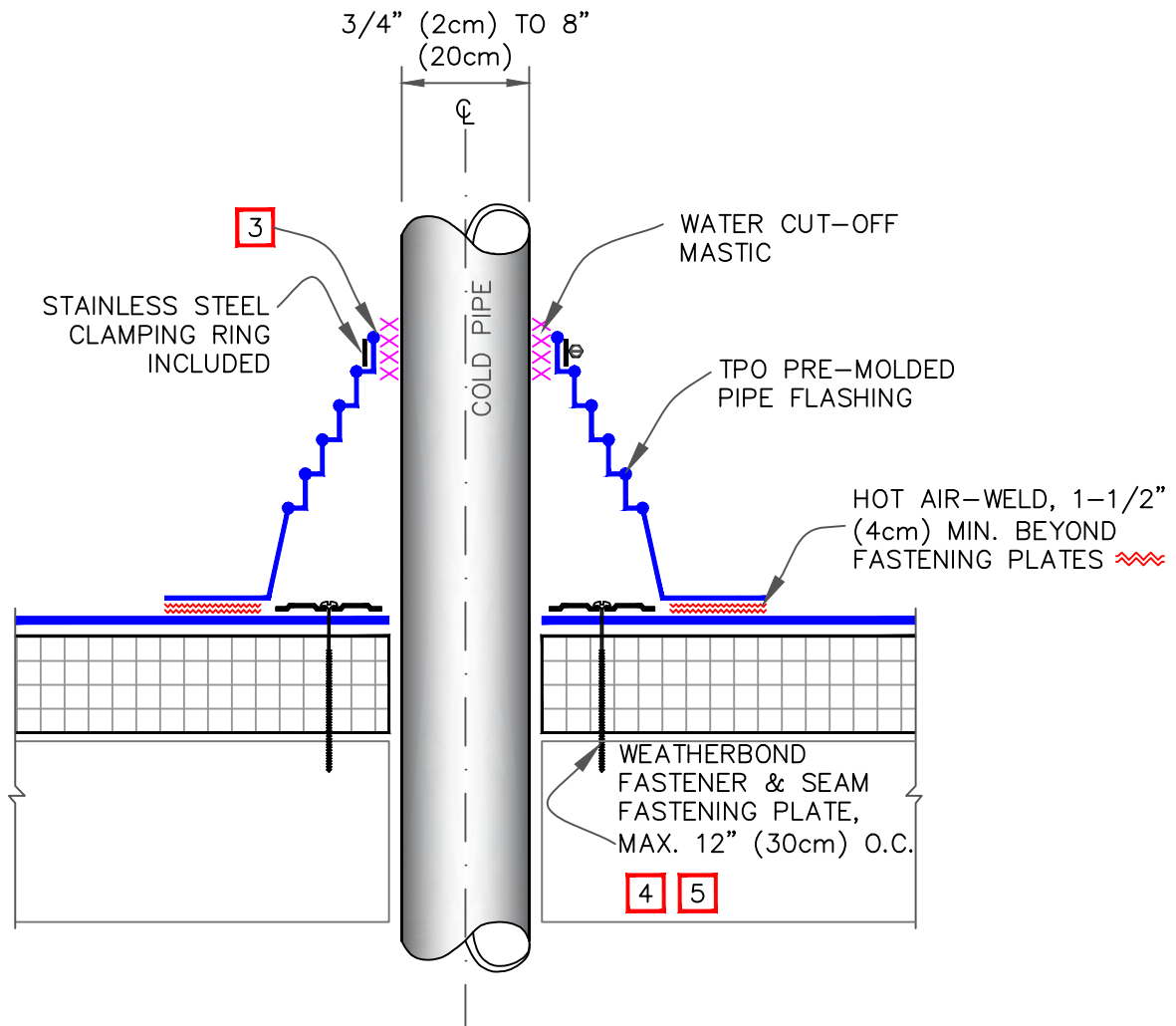

NOTES:

1. REMOVE ALL EXISTING LEAD AND FLASHING MATERIAL BEFORE INSTALLING PRE-MOLDED PIPE FLASHING.
2. TEMPERATURE OF THE PIPE PENETRATION MUST NOT EXCEED 160°F (71°C).
3. PRE-MOLDED PIPE FLASHING MUST HAVE INTACT RIB AT THE TOP EDGE REGARDLESS OF PIPE DIAMETER.
4. INSTALL A MINIMUM OF 4 FASTENERS AND PLATES AROUND THE PIPE, EQUALLY SPACED. IF FASTENERS AND PLATES CANNOT BE INSTALLED AS SHOWN, THEY MAY ALSO BE POSITIONED OUTSIDE THE PIPE MAXIMUM 12" (30cm) O.C. AND FLASHED WITH TPO REINFORCED MEMBRANE / TPO CUT-EDGE SEALANT. REFER TO [DETAIL WBPC-8.2](#).
5. FASTENERS AND PLATES ARE NOT REQUIRED ON ADHERED SYSTEMS UNLESS PIPE DIAMETER EXCEEDS 18" (46cm).

FASTENER & PRESSURE PLATE TYPES FOR DIFFERENT ROOF DECKS

DECK TYPE	OPTION	FASTENER	PLATE
STEEL OR WOOD	A	HPWX	HPWX
	B	HPW-XL	HPW-XL
STRUCTURAL CONCRETE	A	CD-10	HPWX
	B	MP 14-10	HPWX



PRE-MOLDED FLASHING

- TPO MEMBRANE
- APPROVED SUBSTRATE
- SEE NOTE

THERMOPLASTIC ROOFING SYSTEM

WBPC-8.1

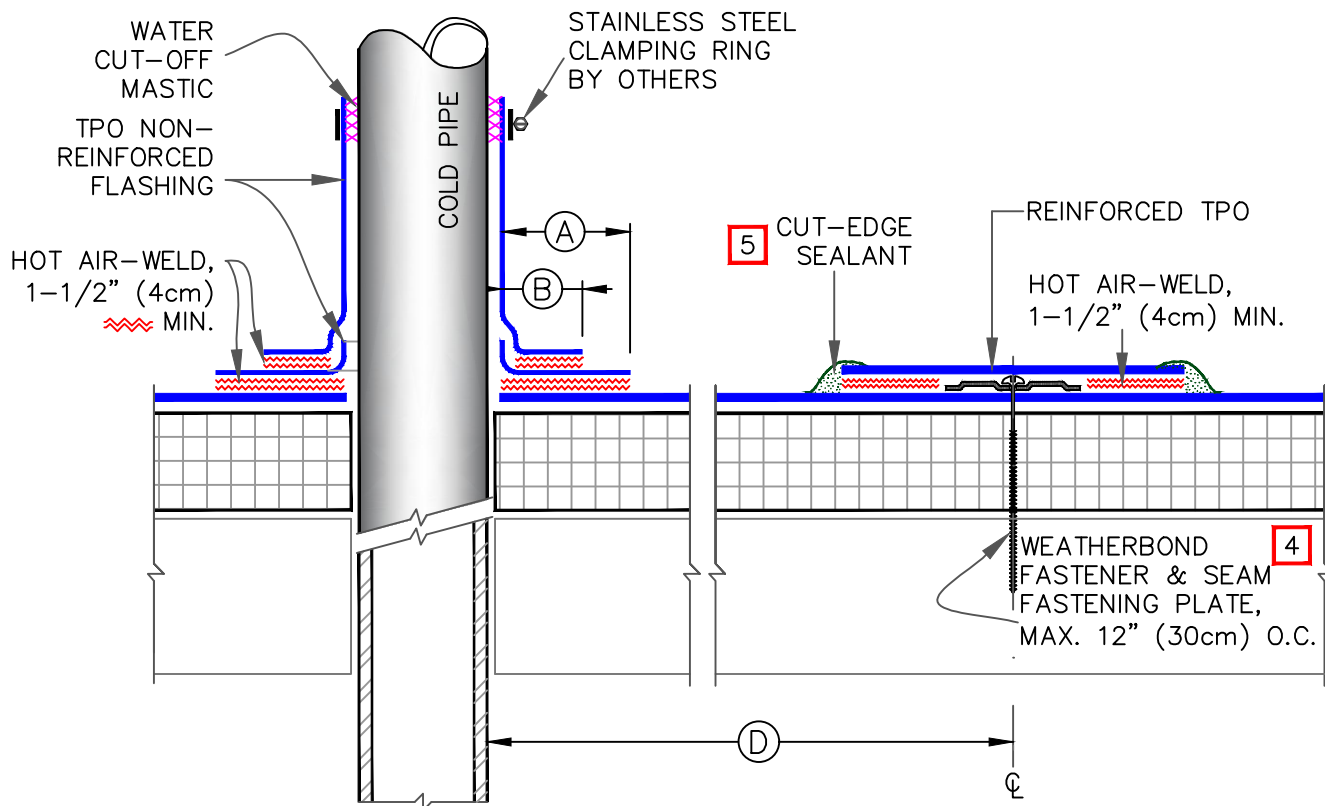

NOTES:

1. REMOVE ALL EXISTING LEAD AND FLASHING MATERIAL BEFORE INSTALLING FIELD FABRICATED PIPE FLASHING.
2. TEMPERATURE OF THE PIPE PENETRATION MUST NOT EXCEED 160°F (71°C).
3. TPO NON-REINFORCED FLASHING WRAPPED AROUND PIPE SHALL HAVE MINIMUM 1-1/2" (4cm) VERTICAL HOT AIR WELD. INSTALL A MINIMUM OF 4 SEAM FASTENING PLATES FOR PIPES WITH A DIAMETER UP TO 6" (15cm). ADDITIONAL SEAM FASTENING PLATES WILL BE REQUIRED FOR PIPES GREATER THAN 6" (15cm) IN DIAMETER AND SHALL BE SPACED 12" (30cm) ON CENTER MAXIMUM.
4. FASTENERS/PLATES ARE NOT REQUIRED ON ADHERED SYSTEMS UNLESS PIPE DIAMETER EXCEEDS 18" (50cm).
5. APPROXIMATELY 1/8" (0.5cm) DIAMETER BEAD OF CUT-EDGE SEALANT IS REQUIRED ON CUT EDGES OF REINFORCED TPO MEMBRANE.

DIMENSIONS		cm	
Ⓐ	1-1/2"	4	TO
	2"	5	
Ⓑ	1"	2.5	MIN.
Ⓒ	1/2"	1.5	MIN.
Ⓓ	12"	30	APPROX.

FASTENER & PRESSURE PLATE TYPES FOR DIFFERENT ROOF DECKS

DECK TYPE	OPTION	FASTENER	PLATE
STEEL OR WOOD	A	HPWX	HPWX
	B	HPW-XL	HPW-XL
STRUCTURAL CONCRETE	A	CD-10	HPWX
	B	MP 14-10	HPWX



FIELD FABRICATED PIPE FLASHING

- • TPO MEMBRANE
- APPROVED SUBSTRATE
- 0 • SEE NOTE

THERMOPLASTIC ROOFING SYSTEM

WBPC-8.2

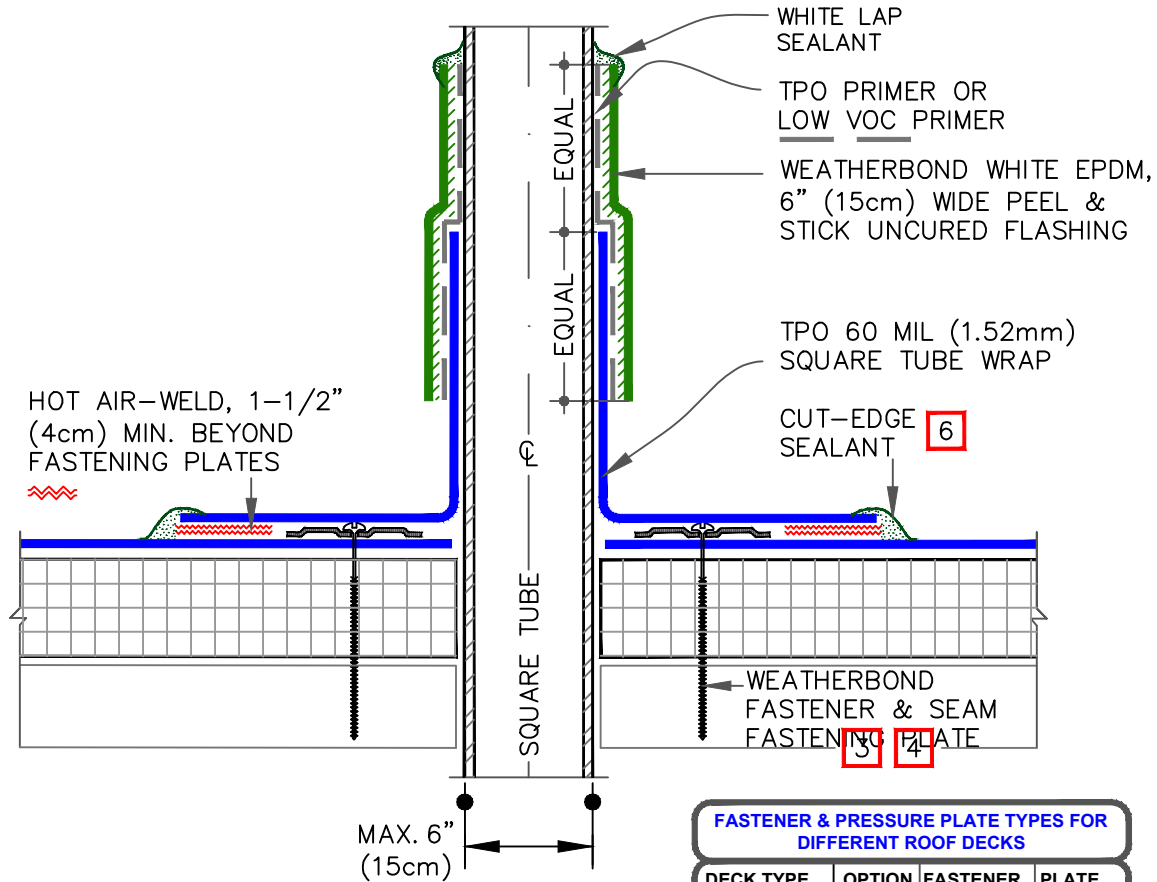

FASTENER & PRESSURE PLATE TYPES FOR DIFFERENT ROOF DECKS

DECK TYPE	OPTION	FASTENER	PLATE
STEEL OR WOOD	A	HPWX	HPWX
	B	HPW-XL	HPW-XL
STRUCTURAL CONCRETE	A	CD-10	HPWX
	B	MP 14-10	HPWX

NOTES:

1. REMOVE ALL EXISTING LEAD AND FLASHING MATERIAL BEFORE INSTALLING PRE-FABRICATED SQUARE TUBE WRAP.
2. TEMPERATURE OF THE PIPE PENETRATION MUST NOT EXCEED 160°F (71°C).
3. INSTALL A MINIMUM OF 4 SEAM FASTENING PLATES FOR TUBE SIDE DIMENSIONS UP TO 6" (15cm).
4. FASTENERS AND PLATES ARE NOT REQUIRED ON ADHERED SYSTEM. SEE TABLE FOR MF SYSTEM.
5. T-JOINT COVERS ARE NOT REQUIRED ON WHITE, TAN OR GRAY, FOR ADDITIONAL COLORS IT IS REQUIRED TO COVER T-JOINTS.
6. APPROXIMATELY 1/8" (0.5cm) DIAMETER BEAD OF CUT-EDGE SEALANT IS REQUIRED ON CUT EDGES OF REINFORCED TPO MEMBRANE.

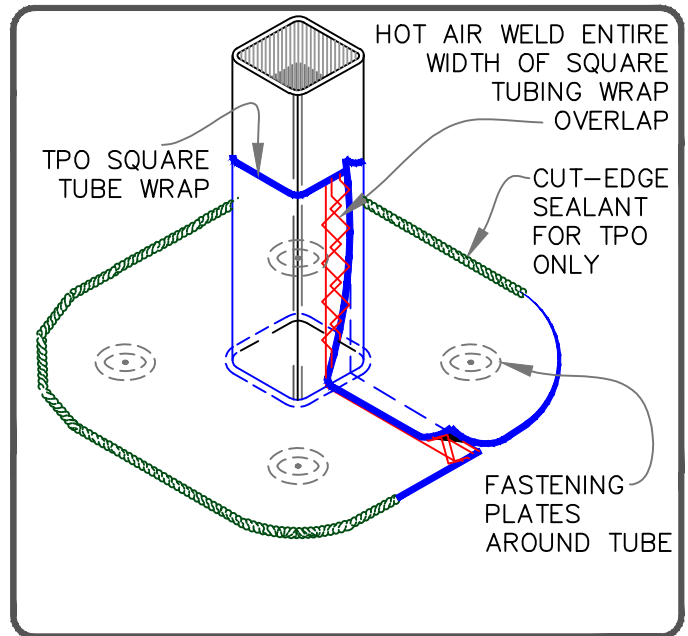

PRE-FABRICATED SQUARE TUBE WRAP

- TPO MEMBRANE
- APPROVED SUBSTRATE
- 0 SEE NOTE

THERMOPLASTIC ROOFING SYSTEM

WBPC-8.3

DIMENSIONS	cm	
(A) 6"	15	MAX.
(B) 1-1/2"	4	MIN.
(C) 1/2"	1.5	MIN.
(D) 1"	2.5	MIN.
(E) 12"	30	APPROX.

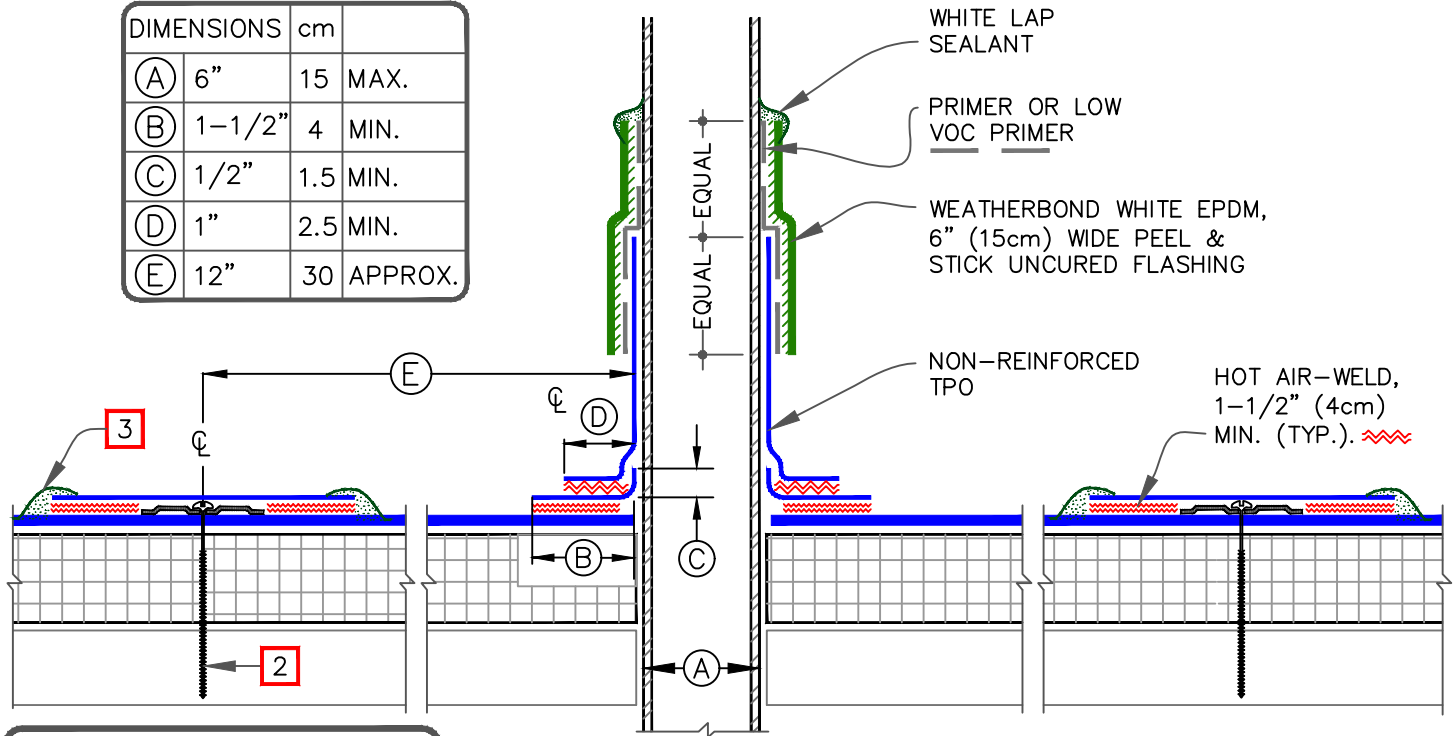

FASTENER & PRESSURE PLATE TYPES FOR DIFFERENT ROOF DECKS

DECK TYPE	OPTION	FASTENER	PLATE
STEEL OR WOOD	A	HPWX	HPWX
	B	HPW-XL	HPW-XL
STRUCTURAL CONCRETE	A	CD-10	HPWX
	B	MP 14-10	HPWX

NOTES:

1. REMOVE ALL EXISTING LEAD AND FLASHING MATERIAL BEFORE INSTALLING PRE-FABRICATED SQUARE TUBE WRAP.
2. WEATHERBOND FASTENERS & SEAM FASTENING PLATES FOR MECHANICALLY FASTENED SYSTEM (NOT REQUIRED ON ADHERED SYSTEM). SEE TABLE ABOVE.
3. APPROXIMATELY 1/8" (0.5cm) DIAMETER BEAD OF CUT-EDGE SEALANT IS REQUIRED ON CUT EDGES OF REINFORCED TPO MEMBRANE.

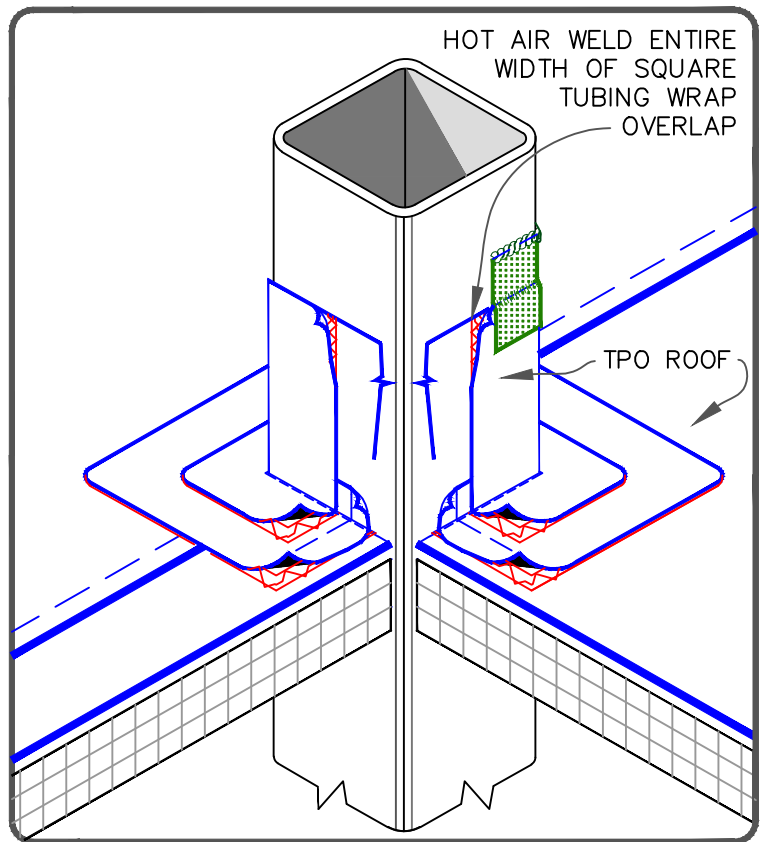

FIELD-FABRICATED SQUARE TUBE FLASHING

- TPO MEMBRANE
- APPROVED SUBSTRATE
- 0 SEE NOTE

THERMOPLASTIC ROOFING SYSTEM

WBPC-8.4

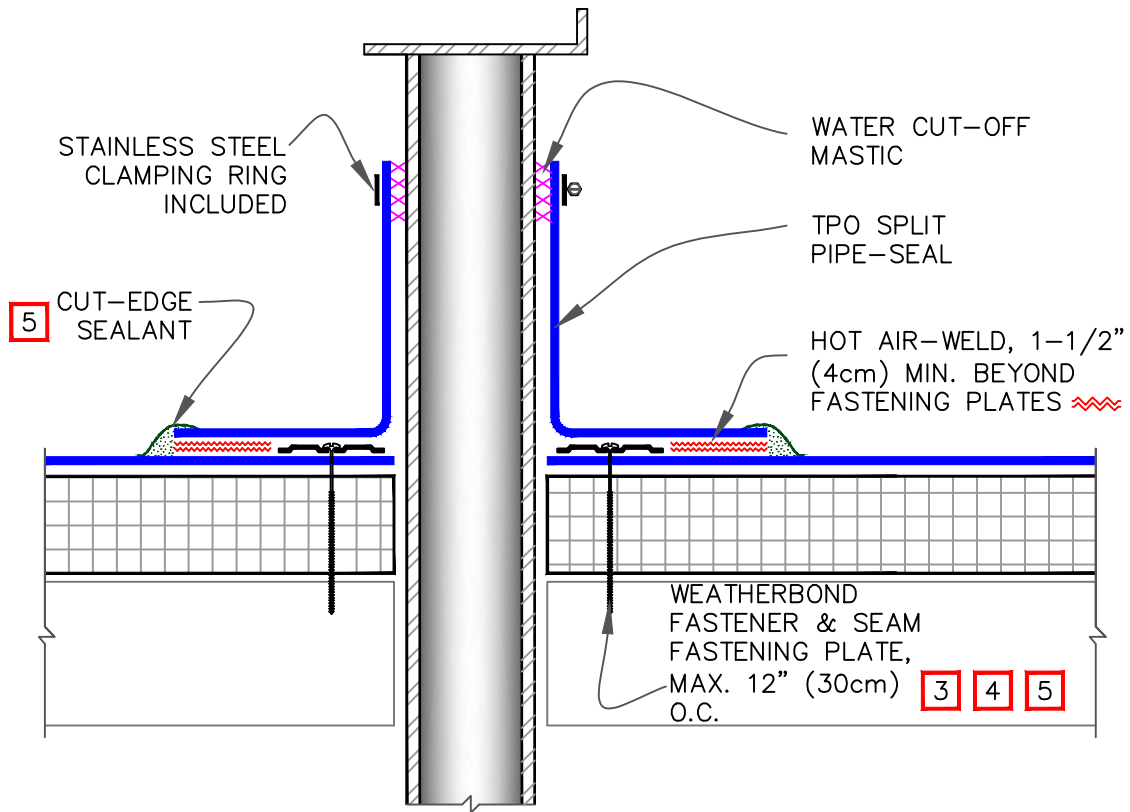

NOTES:

1. REMOVE ALL EXISTING LEAD AND FLASHING MATERIAL BEFORE INSTALLING SPLIT PIPE FLASHING.
2. TEMPERATURE OF THE PIPE PENETRATION MUST NOT EXCEED 160°F (71°C).
3. INSTALL A MINIMUM OF 4 FASTENERS AND PLATES AROUND THE PIPE, EQUALLY SPACED. IF FASTENERS AND PLATES CANNOT BE INSTALLED AS SHOWN, THEY MAY ALSO BE POSITIONED OUTSIDE THE PIPE MAXIMUM 12" (30cm) O.C. AND FLASHED WITH TPO REINFORCED MEMBRANE/CUT-EDGE SEALANT. REFER TO [DETAIL WBPC-8.2](#).
4. FASTENERS AND PLATES ARE NOT REQUIRED ON ADHERED SYSTEMS UNLESS PIPE DIAMETER EXCEEDS 18" (46cm).
5. APPROXIMATELY 1/8" (0.5cm) DIAMETER BEAD OF CUT-EDGE SEALANT IS REQUIRED ON CUT EDGES OF REINFORCED TPO MEMBRANE ONLY.

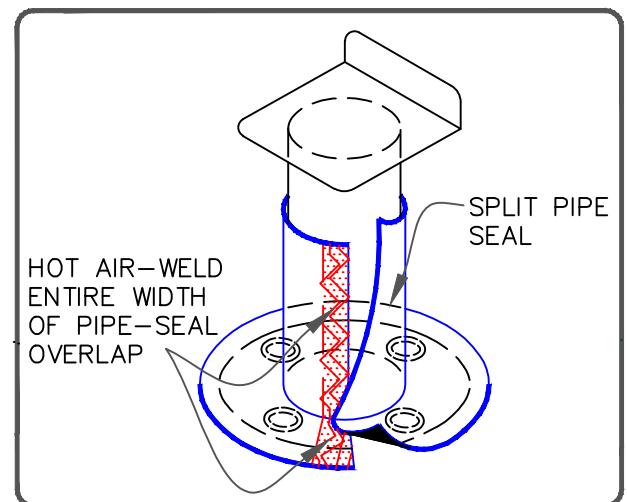

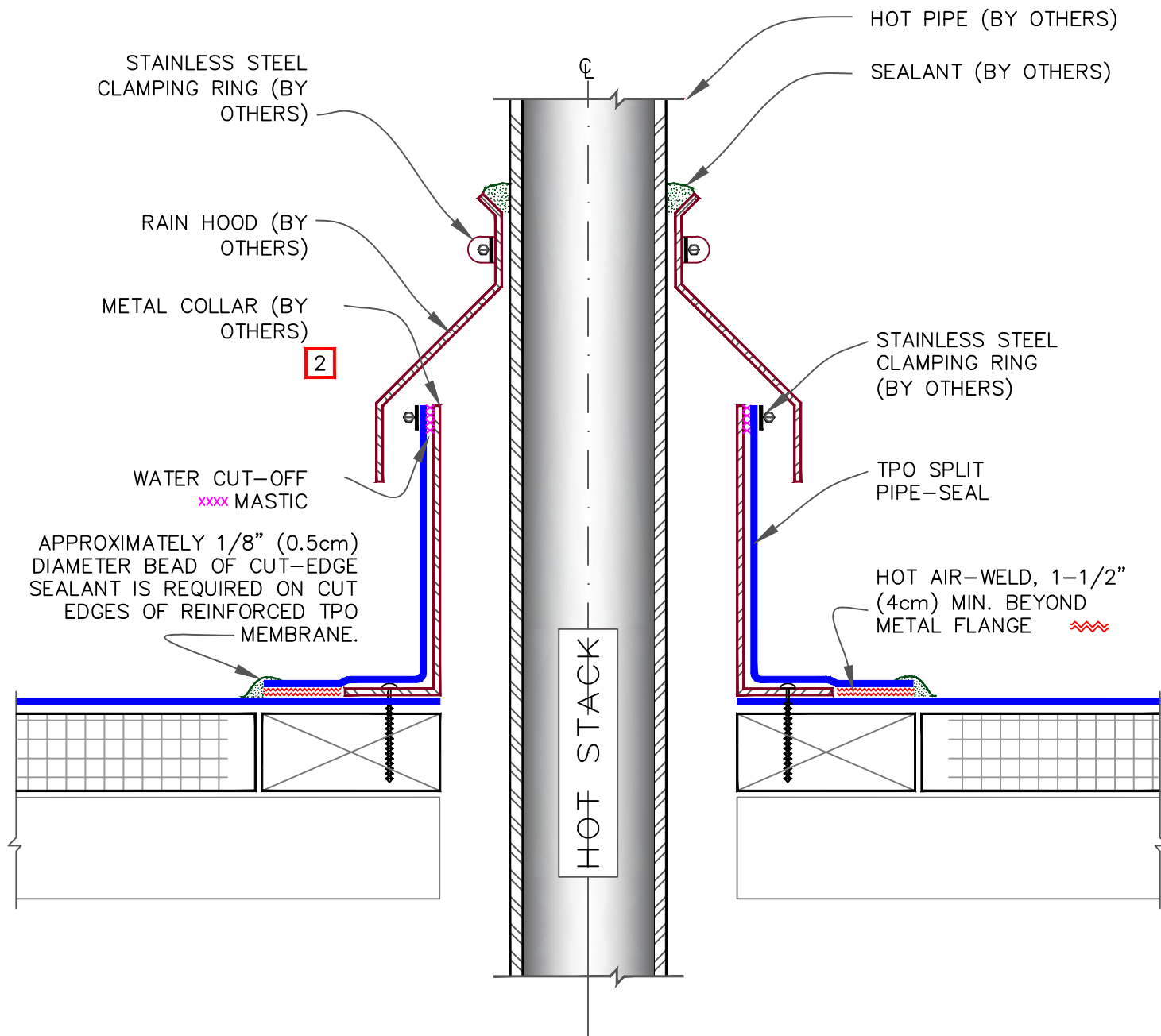

NOTES:

1. REMOVE ALL EXISTING LEAD AND FLASHING MATERIAL BEFORE INSTALLING PIPE FLASHING.
2. TEMPERATURE OF THE METAL COLLAR MUST NOT EXCEED 160°F (71°C).
3. T-JOINT COVERS ARE NOT REQUIRED ON WHITE, TAN OR GRAY, FOR ADDITIONAL COLORS IT IS REQUIRED TO COVER T-JOINTS.

9.1 MECHANICAL TERMINATION WITH COUNTER FLASHING

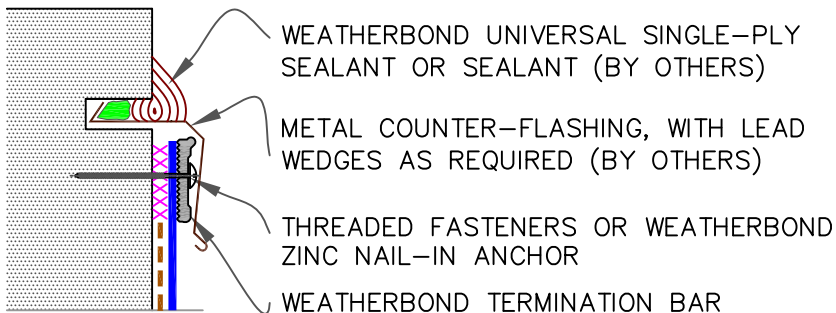

SEE INSET A

9.2 MECHANICAL TERMINATION

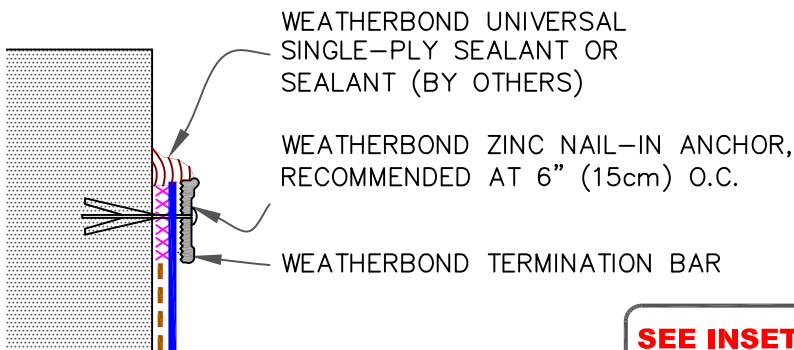

SEE INSET A

9.3 COUNTER FLASHING TERMINATION

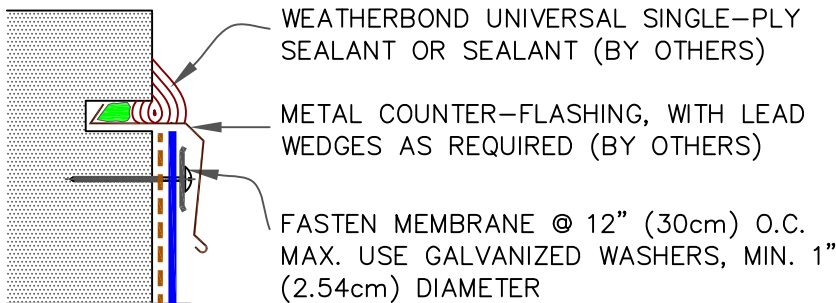

- NOTE:
1. WHEN MECHANICAL FASTENERS ARE USED TO PENETRATE THE METAL COUNTER-FLASHING, USE EPDM WASHERS, APPLY WATER CUT-OFF MASTIC UNDER THE COUNTER-FLASHING OR SEAL THE FASTENER HEADS.

INSET A

MAX. 1" (2.54cm)

MIN. 1/4" (1cm) | MAX. 1/2" (1.5cm)

±1" (2.54cm)

CORNER

NOTES:

1. APPLY ON HARD SMOOTH SURFACE ONLY; NOT FOR USE ON EXPOSED WOOD.
2. DO NOT WRAP TERMINATION BAR AROUND CORNERS.
3. DETAIL 9.4 MUST BE USED AT VERTICAL JOINTS IN PANEL WALLS.

--- APPLICABLE BONDING ADHESIVE

xxx WATER CUT-OFF MASTIC- MUST BE HELD UNDER CONSTANT COMPRESSION.



MEMBRANE TERMINATIONS, PAGE 1 OF 3

—●— TPO MEMBRANE

—●— APPROVED SUBSTRATE

0 —●— SEE NOTE

THERMOPLASTIC ROOFING SYSTEM

WBPC-9.0A

9.4 MECHANICAL TERMINATION AT VERTICAL JOINTS

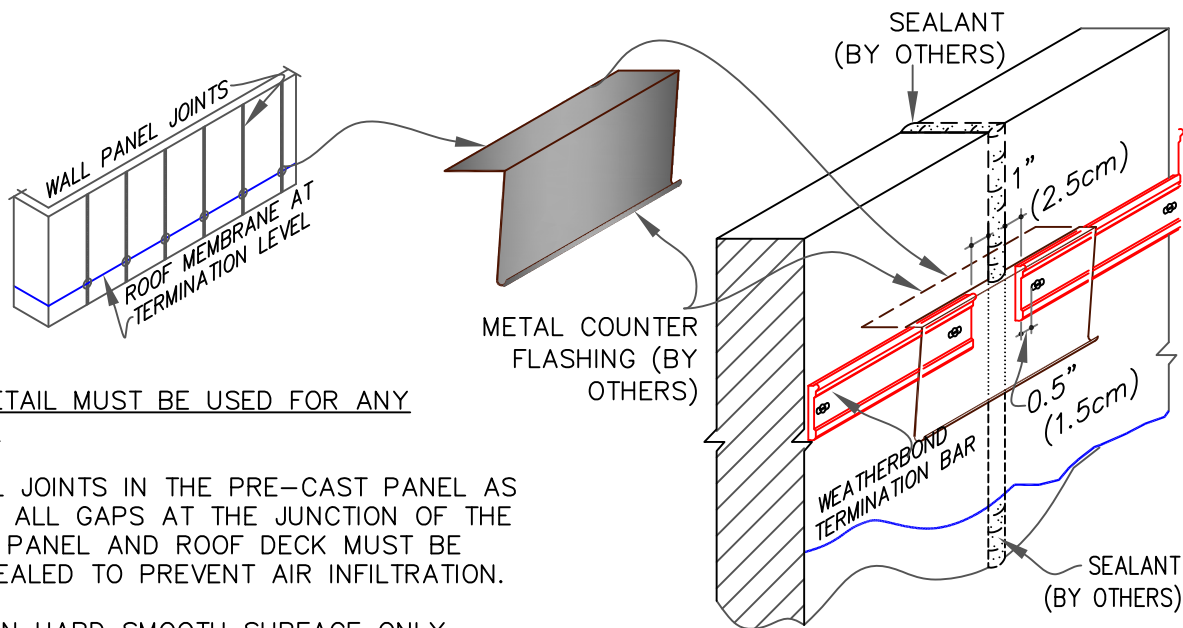

NOTES:

1. THIS DETAIL MUST BE USED FOR ANY PROJECT
2. VERTICAL JOINTS IN THE PRE-CAST PANEL AS WELL AS ALL GAPS AT THE JUNCTION OF THE TILT-UP PANEL AND ROOF DECK MUST BE FULLY SEALED TO PREVENT AIR INFILTRATION.
3. APPLY ON HARD SMOOTH SURFACE ONLY.

--- APPLICABLE BONDING ADHESIVE

xxx WATER CUT-OFF MASTIC- MUST BE HELD UNDER CONSTANT COMPRESSION.



MEMBRANE TERMINATIONS,
PAGE 2 OF 3

- TPO MEMBRANE
- APPROVED SUBSTRATE
- 0 SEE NOTE

THERMOPLASTIC
ROOFING SYSTEM
WBPC-9.0B

9.5 SHEET METAL COPING (BY OTHERS)

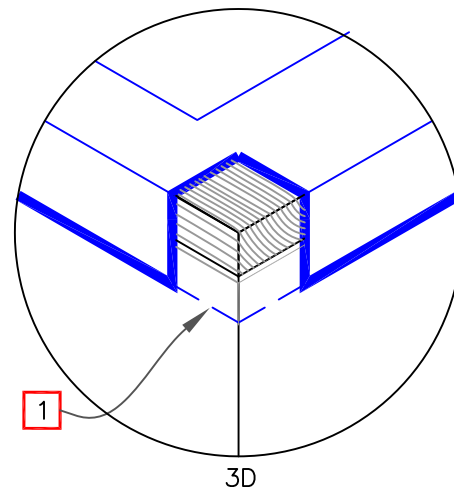
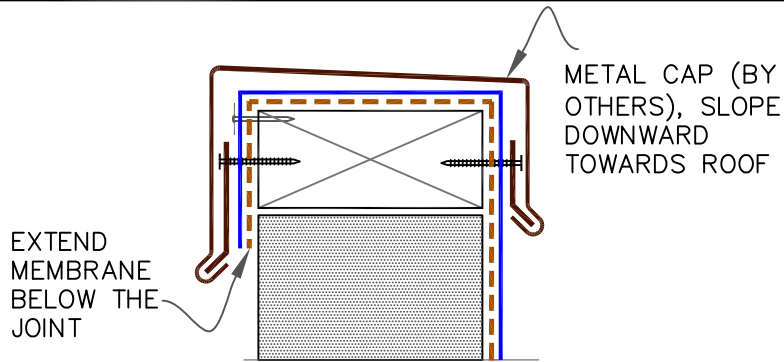

NOTES:

1. MEMBRANE MUST BE EXTENDED TO CORNERS TO PROVIDE COMPLETE COVERAGE OF THE TOP WALL SURFACE.

9.6 MASONRY COPINGS (BY OTHERS)

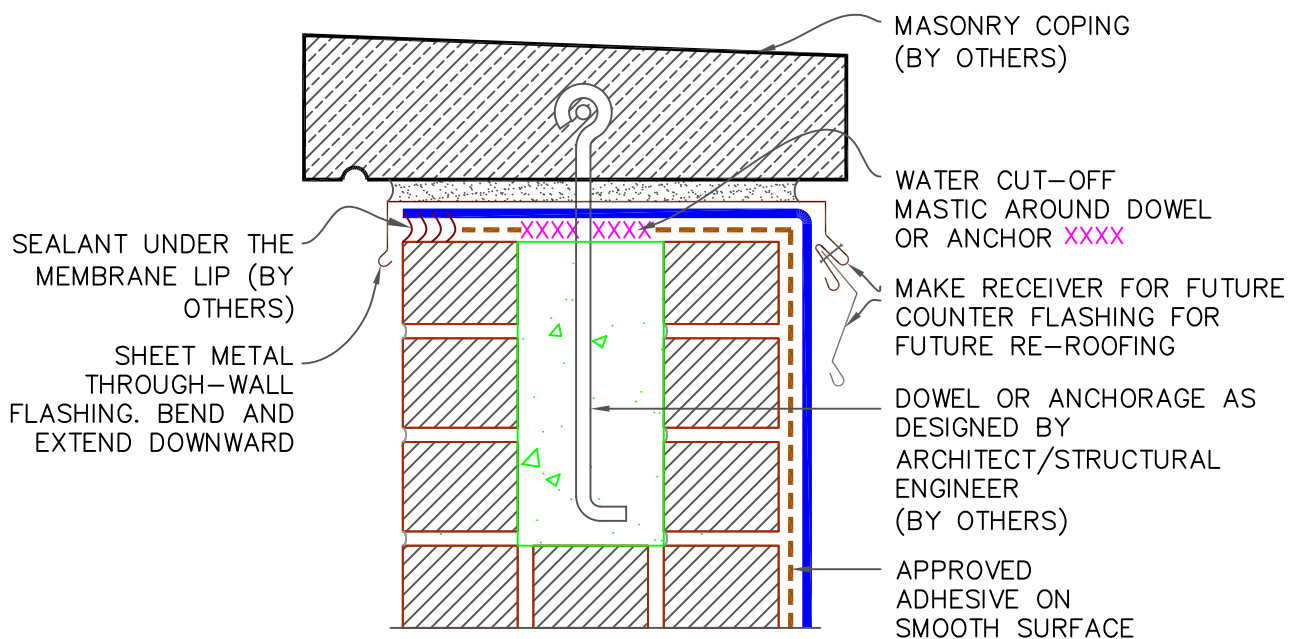

--- APPLICABLE BONDING ADHESIVE

XXX WATER CUT-OFF MASTIC- MUST BE HELD UNDER CONSTANT COMPRESSION.



MEMBRANE TERMINATIONS,
PAGE 3 OF 3

- TPO MEMBRANE
- APPROVED SUBSTRATE
- SEE NOTE

THERMOPLASTIC
ROOFING SYSTEM
WBPC-9.0C

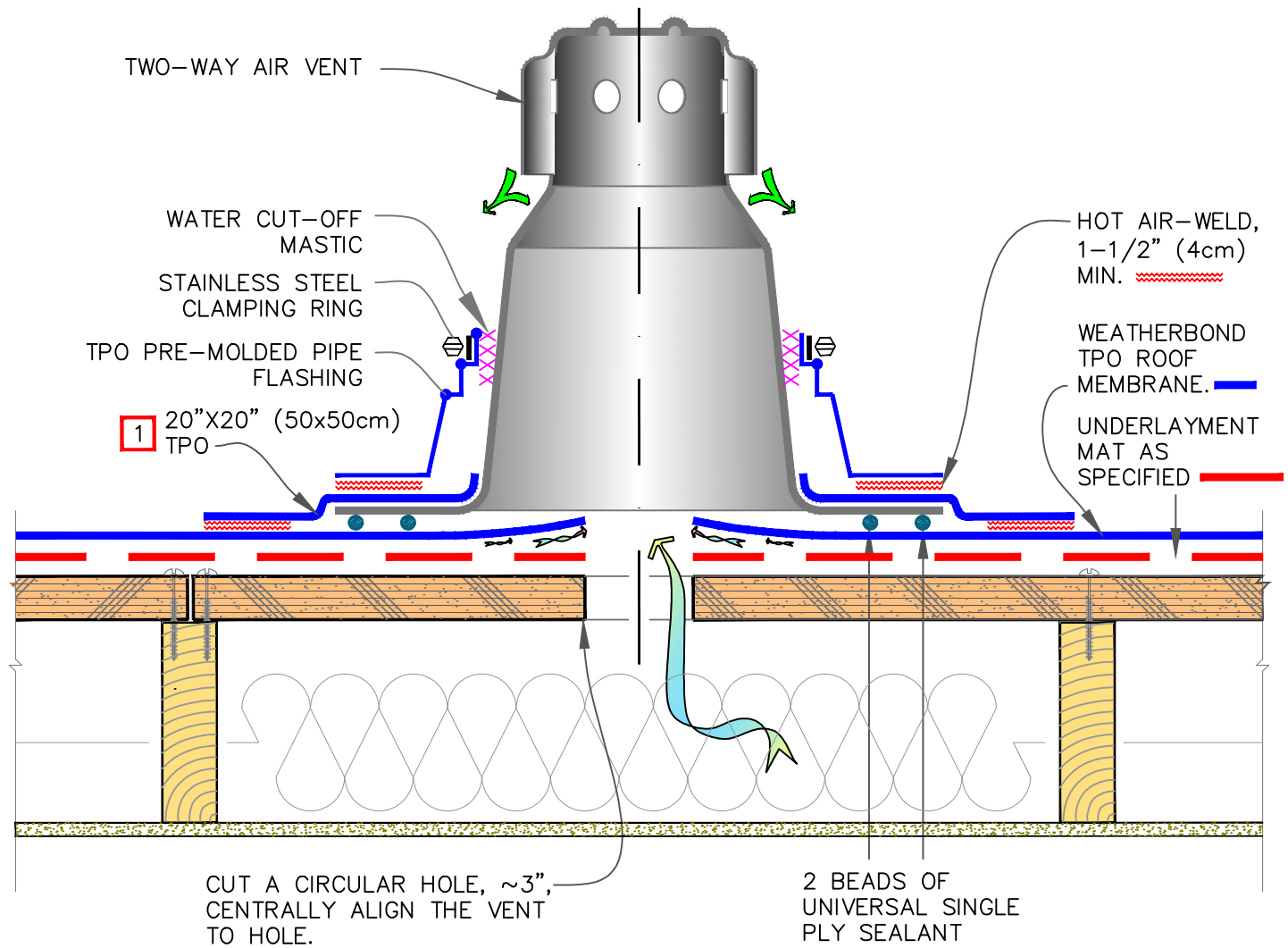

NOTES:

1. CUT SQUARE PIECE, TRIM ROUNDED EDGES, DRAW CENTER LINES AND CUT A 5-1/2" (14cm) DIAMETER HOLE AT THE CENTER OF PIECE. SLIDE THE PIECE THROUGH THE VENT.
2. ONE VENT PER 2,000 S.F. PROPERLY SPACED. MIN. 2 VENTS IF ROOF IS <2,000 S.F., AND INSTALL AT OPPOSITE CORNERS WITHIN 8'X8' CORNER AREA.
3. AVOID VENTS IN VALLEYS/LOWS/TRAFFIC AREAS OR NEAR THE ROOF EDGES AND PARAPET WALLS. POSITION VENTS AT LEAST 7'-0" FROM ROOF EDGE.
4. INSTALL MIN. 4 FASTENERS AT 4 CORNERS @ 12" FROM THE OUTER EDGE OF VENT. SEE [DETAIL A](#).

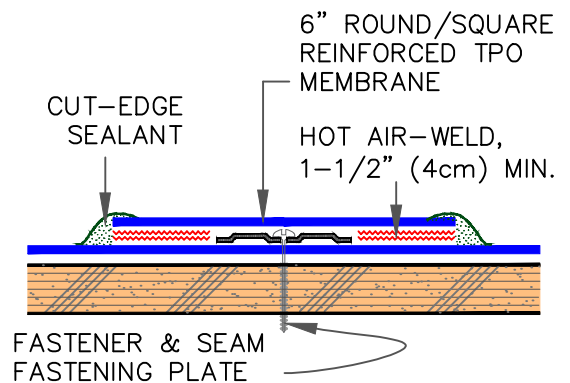

DETAIL A: REQUIRED FASTENING AROUND EACH VENT FOR MF ASSEMBLY



MOISTURE RELIEF VENT FOR MF SYSTEM

- TPO MEMBRANE
- APPROVED SUBSTRATE
- SEE NOTE

OTHER TPO ROOFING SYSTEMS
WBPC-9.1

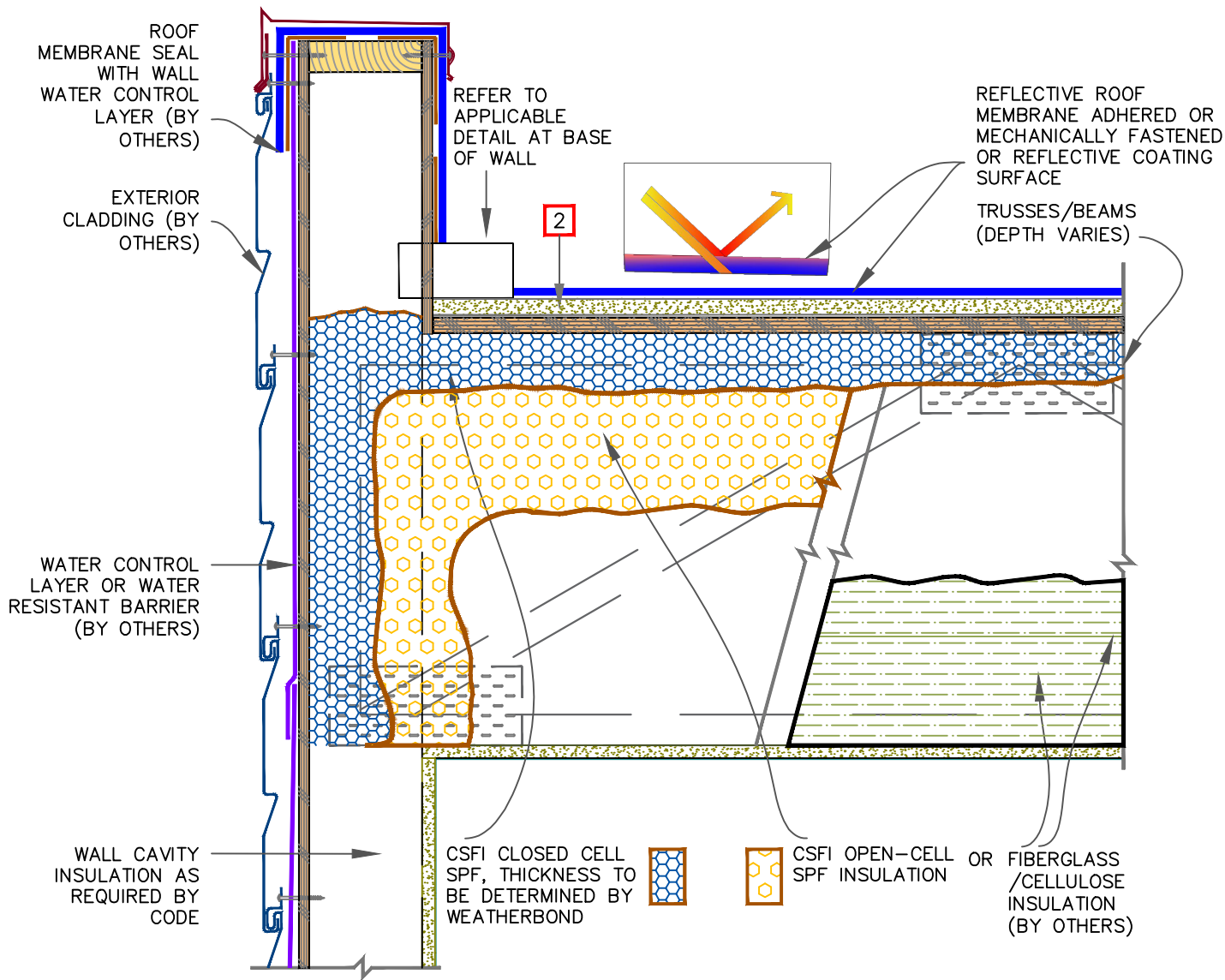

NOTES:

1. DETAIL IS SUITABLE FOR **NEW CONSTRUCTION** TO AVOID FUTURE CONDENSATION DUE TO REFLECTIVE ROOF MEMBRANES OR REFLECTIVE ROOF COATINGS RESULTING IN LOWER DEW POINT TEMPERATURES WITHIN ROOF ASSEMBLY.
2. THERMAL BARRIER AS REQUIRED PER CODE.
3. R-VALUE & THICKNESS OF ATTIC INSULATION TO COMPLY WITH APPLICABLE CODE.



LOW-SLOPE ROOF:
SEALING THE UNDERSIDE
OF THE DECK TO
PREVENT CONDENSATION

- ● TPO MEMBRANE
- APPROVED SUBSTRATE
- 0 ● SEE NOTE

THERMOPLASTIC
ROOFING SYSTEM

WBPC-9.2

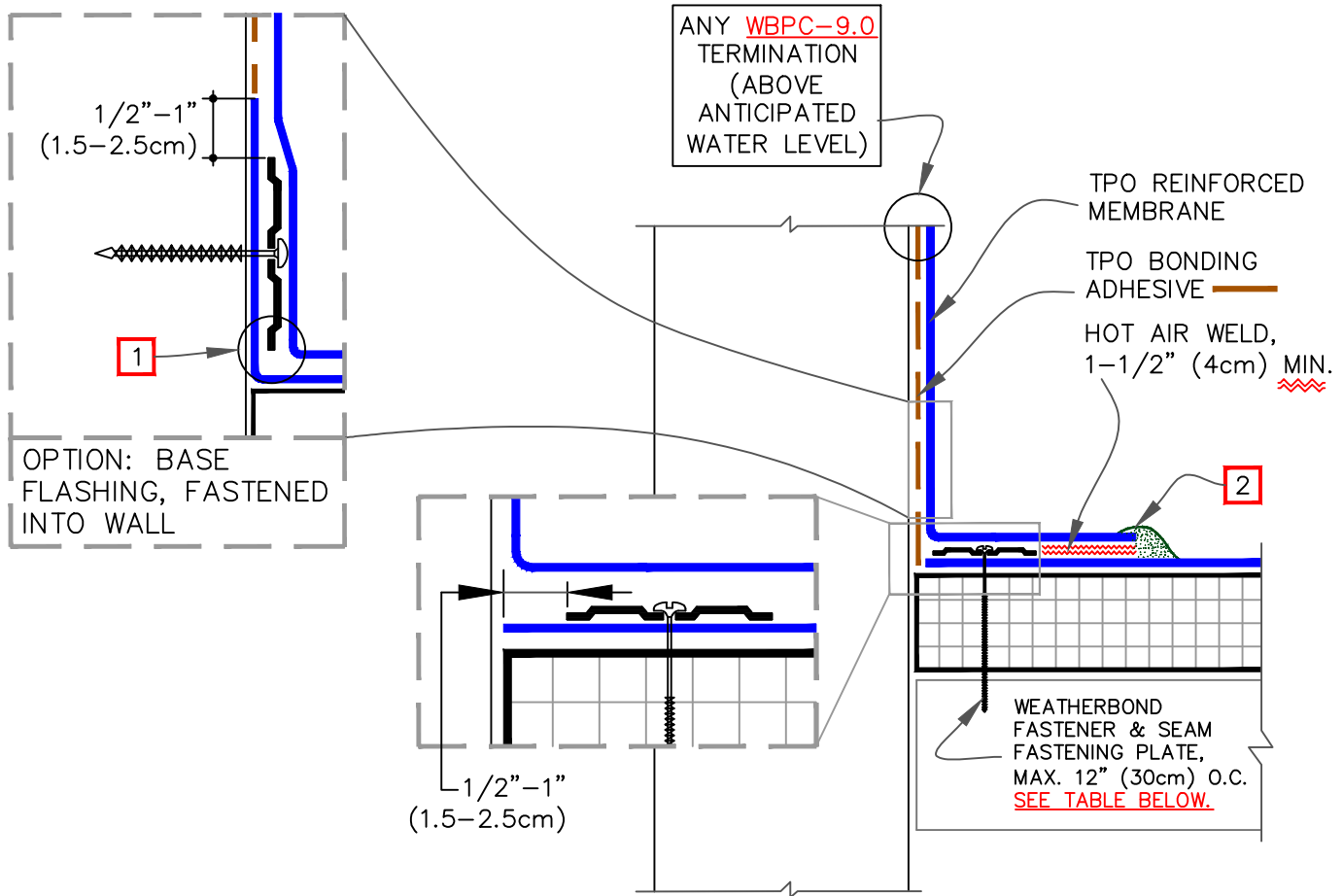

FASTENER & PRESSURE PLATE TYPES FOR DIFFERENT ROOF DECKS

DECK TYPE	OPTION	FASTENER	PLATE
STEEL OR WOOD	A	HPWX	HPWX
	B	HPW-XL	HPW-XL
STRUCTURAL CONCRETE	A	CD-10	HPWX
	B	MP 14-10	HPWX

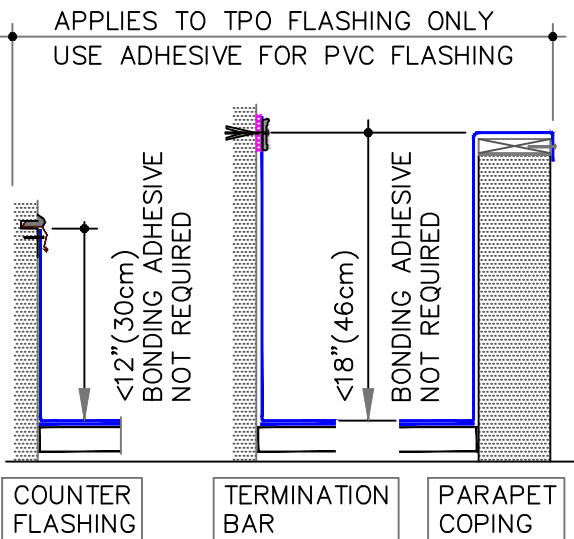

NOTES:

- CARE MUST BE TAKEN TO PRESS THE MEMBRANE TIGHTLY INTO THE ANGLE CHANGE. PLACING THE PLATES TIGHT INTO THE ANGLE CHANGE WILL HELP HOLD THE MEMBRANE IN THE PROPER POSITION.
- APPROXIMATELY 1/8" (0.5cm) DIAMETER BEAD OF CUT-EDGE SEALANT IS REQUIRED ON CUT EDGES OF REINFORCED TPO MEMBRANE.



PARAPET FLASHING

- TPO MEMBRANE
- APPROVED SUBSTRATE
- SEE NOTE

THERMOPLASTIC ROOFING SYSTEM

WBPC-12.1

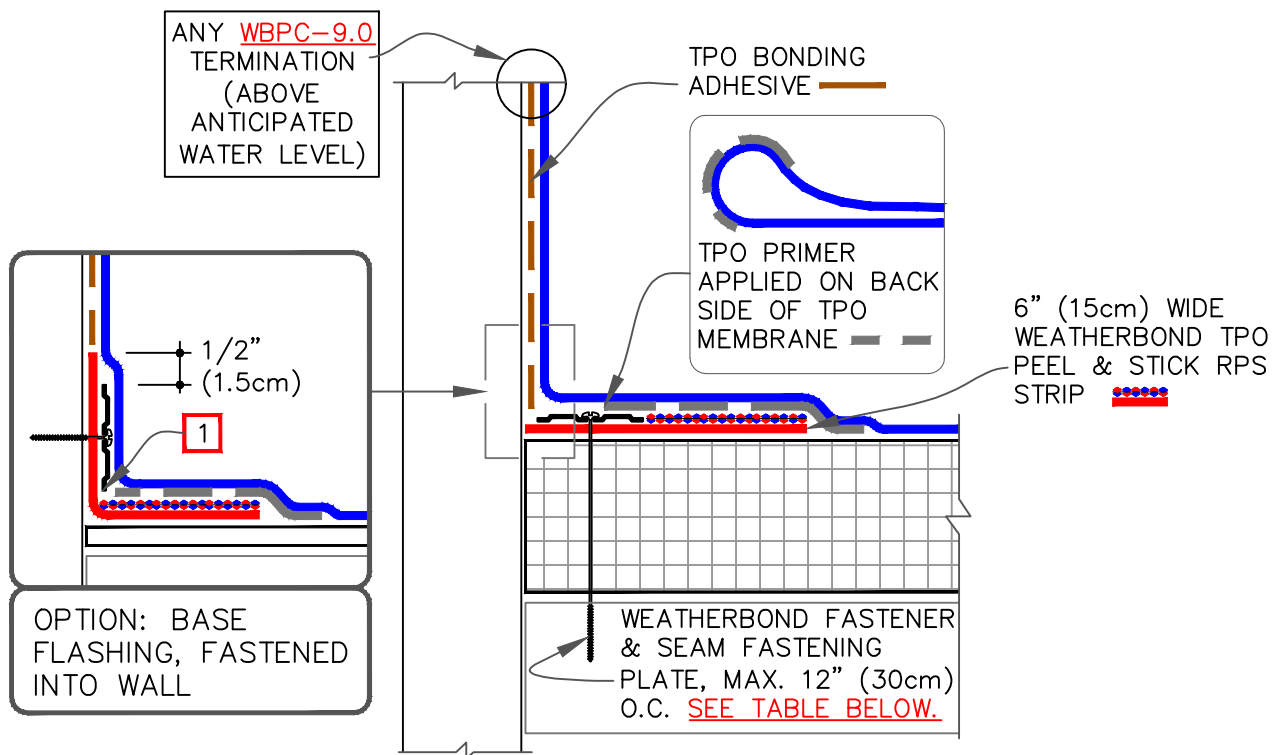

NOTE:

1. IN A CASE WHERE FASTENERS MUST BE FASTENED INTO THE VERTICAL SURFACE, CARE MUST BE TAKEN TO PRESS THE QA RTS, AS WELL AS THE MEMBRANE, TIGHTLY INTO THE ANGLE CHANGE TO MAXIMIZE CONTACT BETWEEN THE TAPE AND MEMBRANE. MEMBRANE MUST BE ADHERED TO THE FULL WIDTH OF THE TAPE. PLACING THE PLATES TIGHT INTO THE ANGLE CHANGE WILL HELP HOLD THE QA RTS IN THE PROPER POSITION.

FASTENER TYPES ON MECHANICALLY FASTENED ROOF ASSEMBLY			
DECK TYPE	OPTION	FASTENER	PLATE
STEEL OR WOOD	A	HPVX	HPVX
	B	HPV-XL	HPV-XL
STRUCTURAL CONCRETE	A	CD-10	HPVX
	B	MP 14-10	HPVX



PARAPET FLASHING WITH PEEL & STICK RPS, PAGE 1 OF 2

- TPO MEMBRANE
- APPROVED SUBSTRATE
- 0 SEE NOTE

THERMOPLASTIC ROOFING SYSTEM

WBPC-12.2A

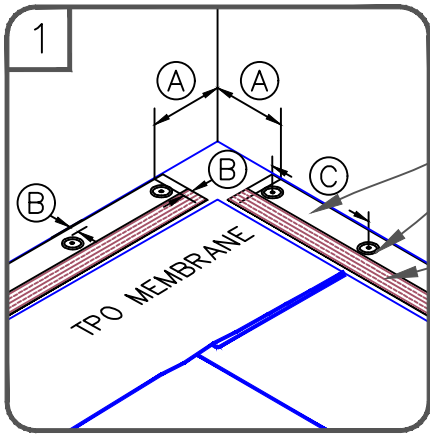

6" (15cm) WIDE PEEL & STICK REINFORCED PERIMETER STRIP (RPS)

WEATHERBOND FASTENER & SEAM FASTENING PLATE, MAX. 12" (30cm) O.C.

PRE-APPLIED PEEL & STICK TAPE

TPO PRIMER

WEATHERBOND ADHESIVE

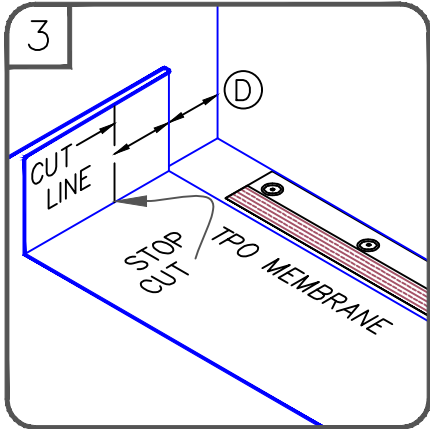
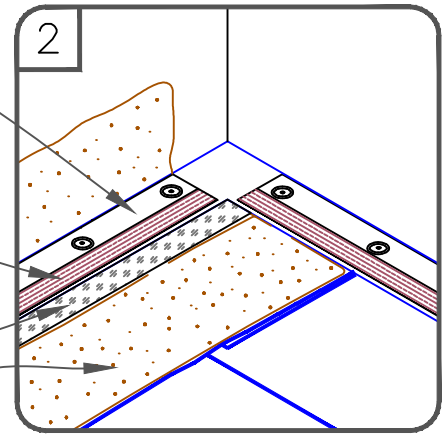

DIMENSIONS		cm	
(A)	6"	15	TO
	9"	23	
(B)	1/8"	0.5	MIN.
	1"	2.5	MAX.
(C)	12"	30	MIN.
(D)	6"	15	MIN.
(E)	1-1/2"	4	MIN.

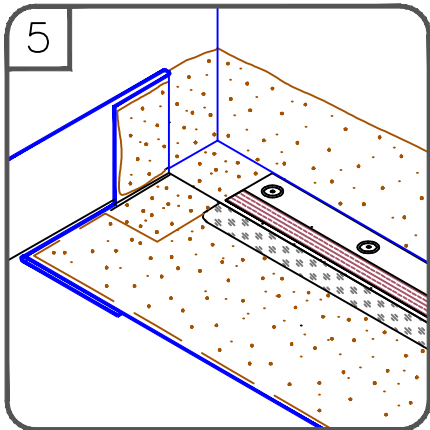
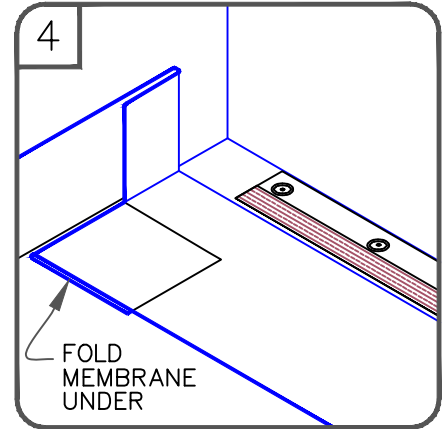

HOT AIR WELD FLAP IN [STEP 7](#)

CUT AT 45°

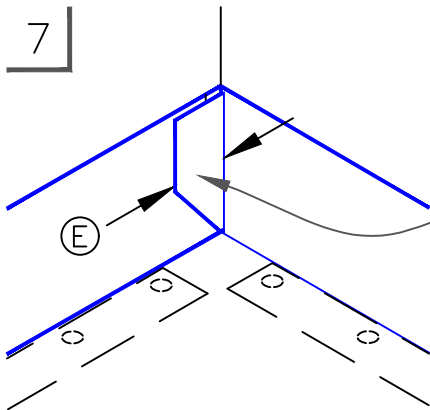
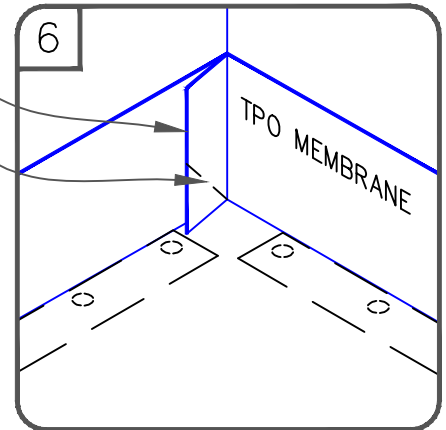

HOT AIR WELD

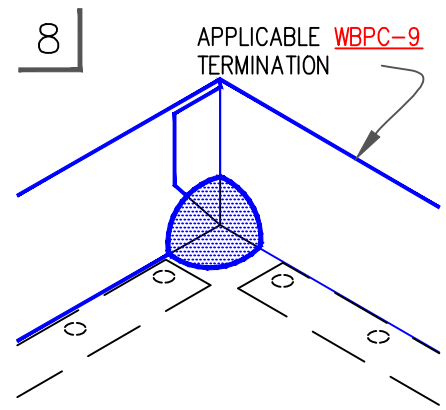

APPLICABLE [WBPC-9](#) TERMINATION

NOTES:

1. THE CUT SECTION OF VERTICAL MEMBRANE WILL BE FOLDED UNDER THE FIELD MEMBRANE AS SHOWN IN [STEP 4](#).
2. APPLY INSIDE CORNER IN ACCORDANCE WITH WEATHERBOND [DETAILS WBPC-15.1 OR WBPC-15.2](#).

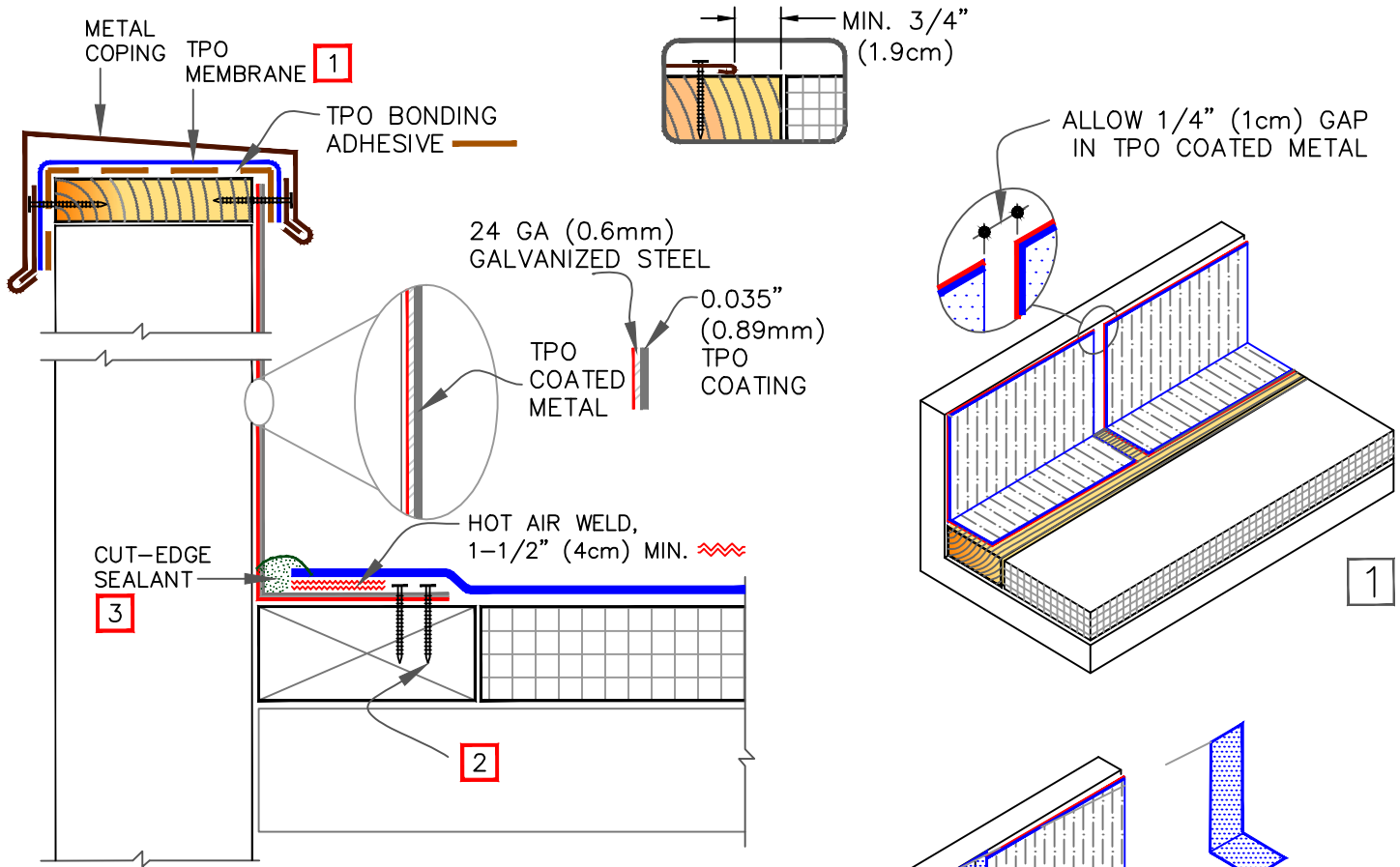

SEQUENCE:

1. 3" (7.6cm) REINFORCED MEMBRANE STRIPPING.
2. FIELD MEMBRANE.
3. TOP 6" (15.2cm) NON-REINFORCED MEMBRANE STRIPPING.

NOTES:

1. PLACE A LAYER OF TPO MEMBRANE UNDER THE METAL CAP TO PROTECT AGAINST MOISTURE INFILTRATION AT JOINTS.
2. FASTEN COATED METAL FLASHING TO WOOD NAILERS USING 1-1/2" (4cm) MIN. RING SHANK NAILS SPACED 6" (15cm) ON CENTER AND STAGGERED APPROX. 1/2" (1.5cm).
3. APPROXIMATELY 1/8" (0.5cm) DIAMETER BEAD OF CUT-EDGE SEALANT IS REQUIRED ON CUT EDGES OF REINFORCED TPO MEMBRANE.
4. SEE [WBPC-15.3](#) FOR ADDITIONAL INFORMATION.

HEAT WELD 3" (7.5cm) WIDE PIECE OF REINFORCED MEMBRANE CENTRALLY ALIGNED OVER JOINT

HEAT WELD 6" (15cm) WIDE PIECE OF NON-REINFORCED MEMBRANE CENTRALLY ALIGNED OVER JOINT, COVERING TOP OF FIELD MEMBRANE. SEE SEQUENCE IN TABLE.

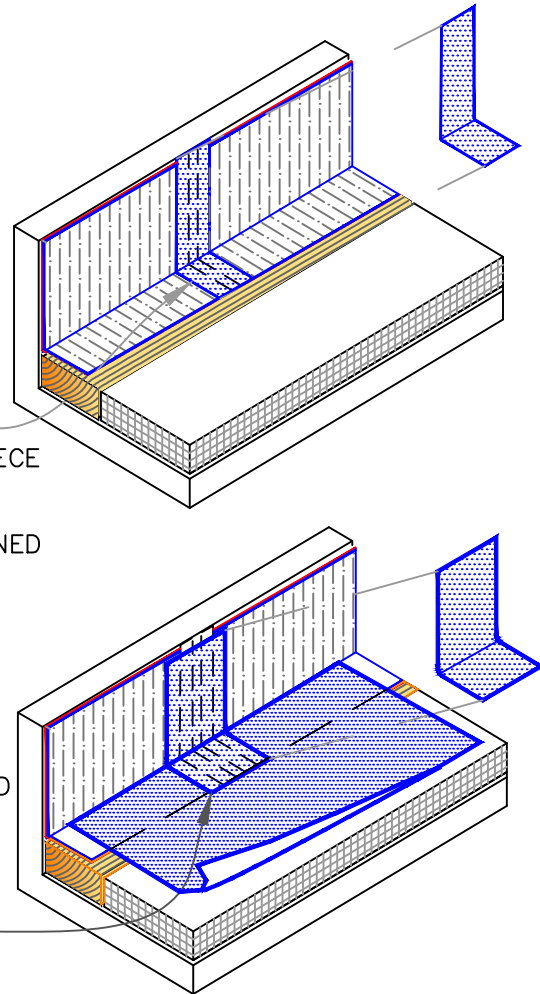

COATED METAL WALL FLASHING

- TPO MEMBRANE
- APPROVED SUBSTRATE
- SEE NOTE

THERMOPLASTIC ROOFING SYSTEM

WBPC-12.3

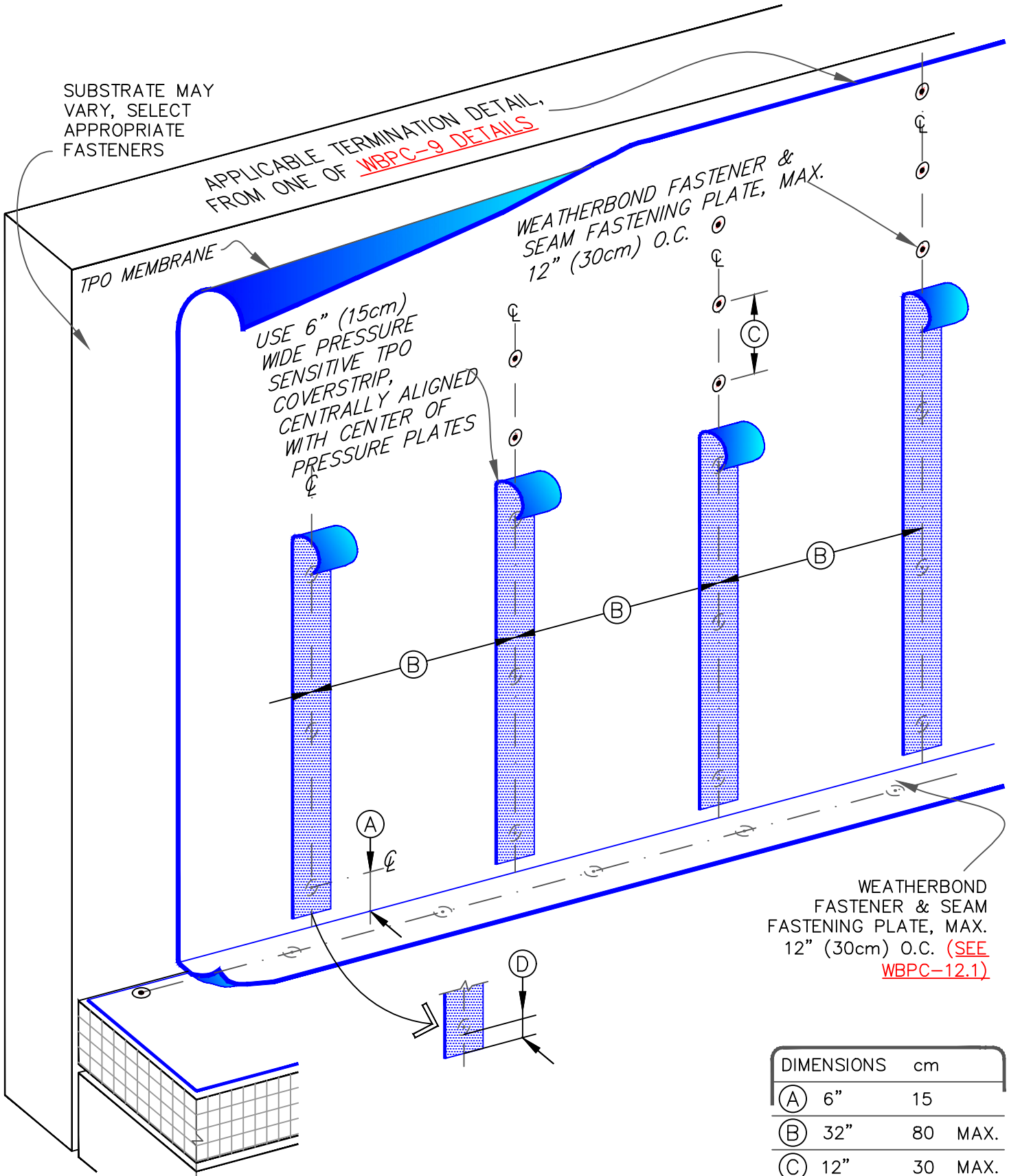

PARAPET FLASHING / NO ADHESION - ANY HEIGHT OPTION

- TPO MEMBRANE
- APPROVED SUBSTRATE
- SEE NOTE

TERMOPLASTIC ROOFING SYSTEM

WBPC-12.6

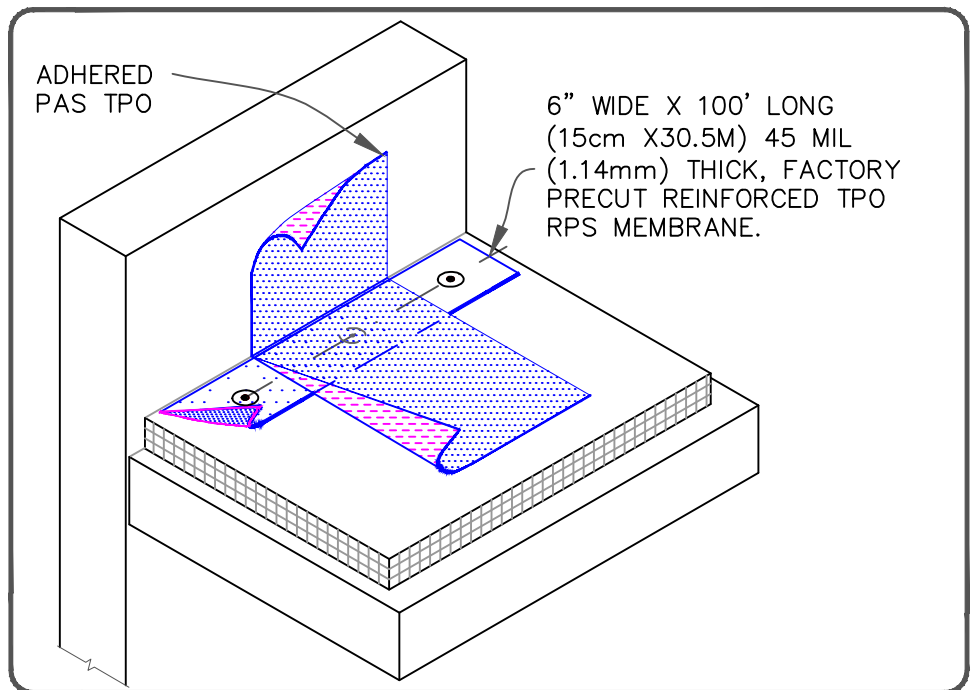
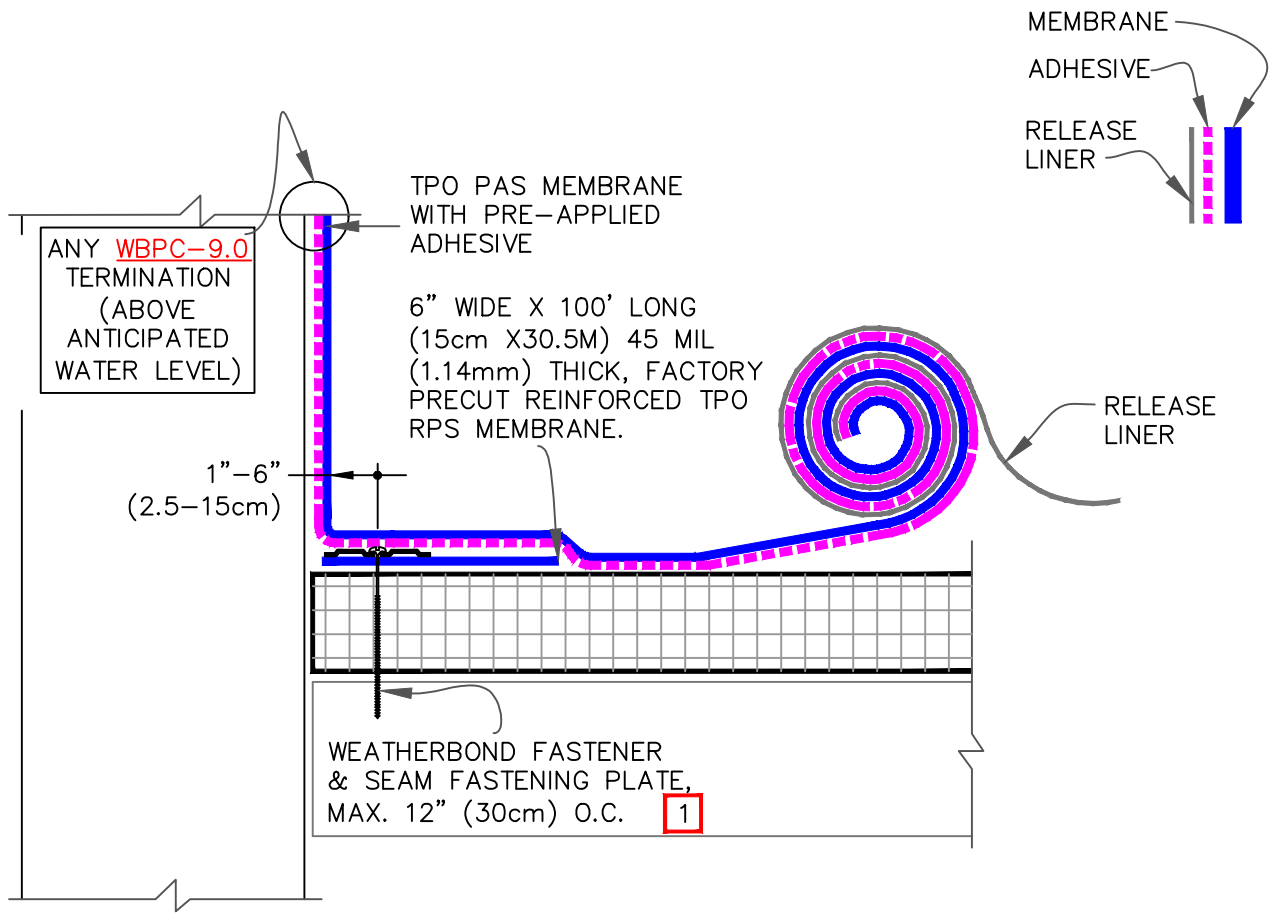

TPO WITH PAS (PEEL AND STICK) TECHNOLOGY



RPS (REINFORCED PERIMETER STRIP)



WEATHERBOND PAS TPO
PARAPET FLASHING WITH
TPO PAS RPS

-  TPO MEMBRANE
-  APPROVED SUBSTRATE
-  SEE NOTE

THERMOPLASTIC
ROOFING SYSTEM
WBPC-12.7

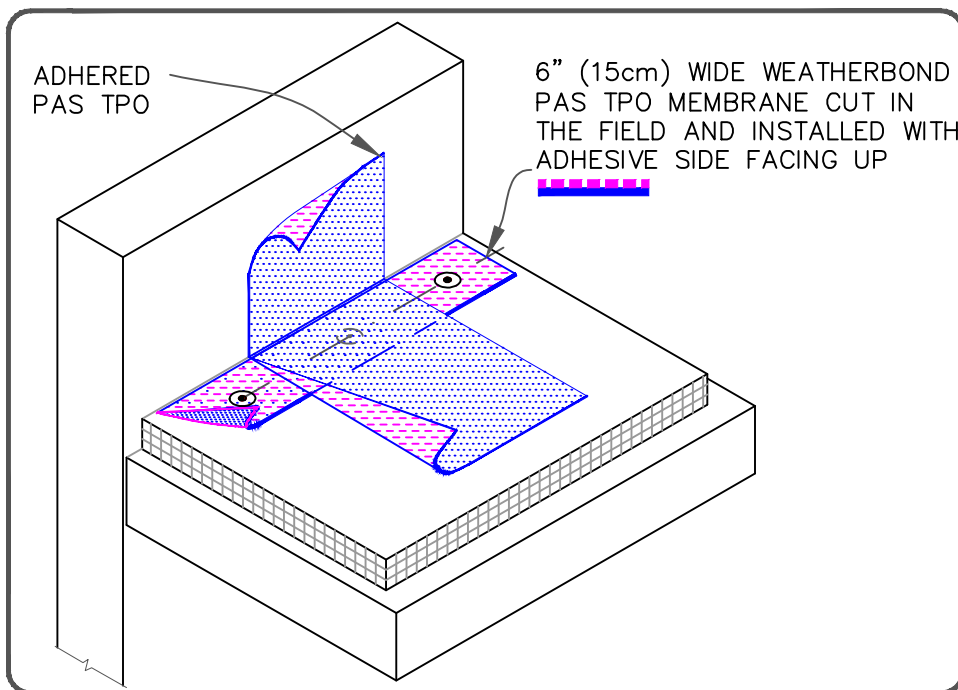
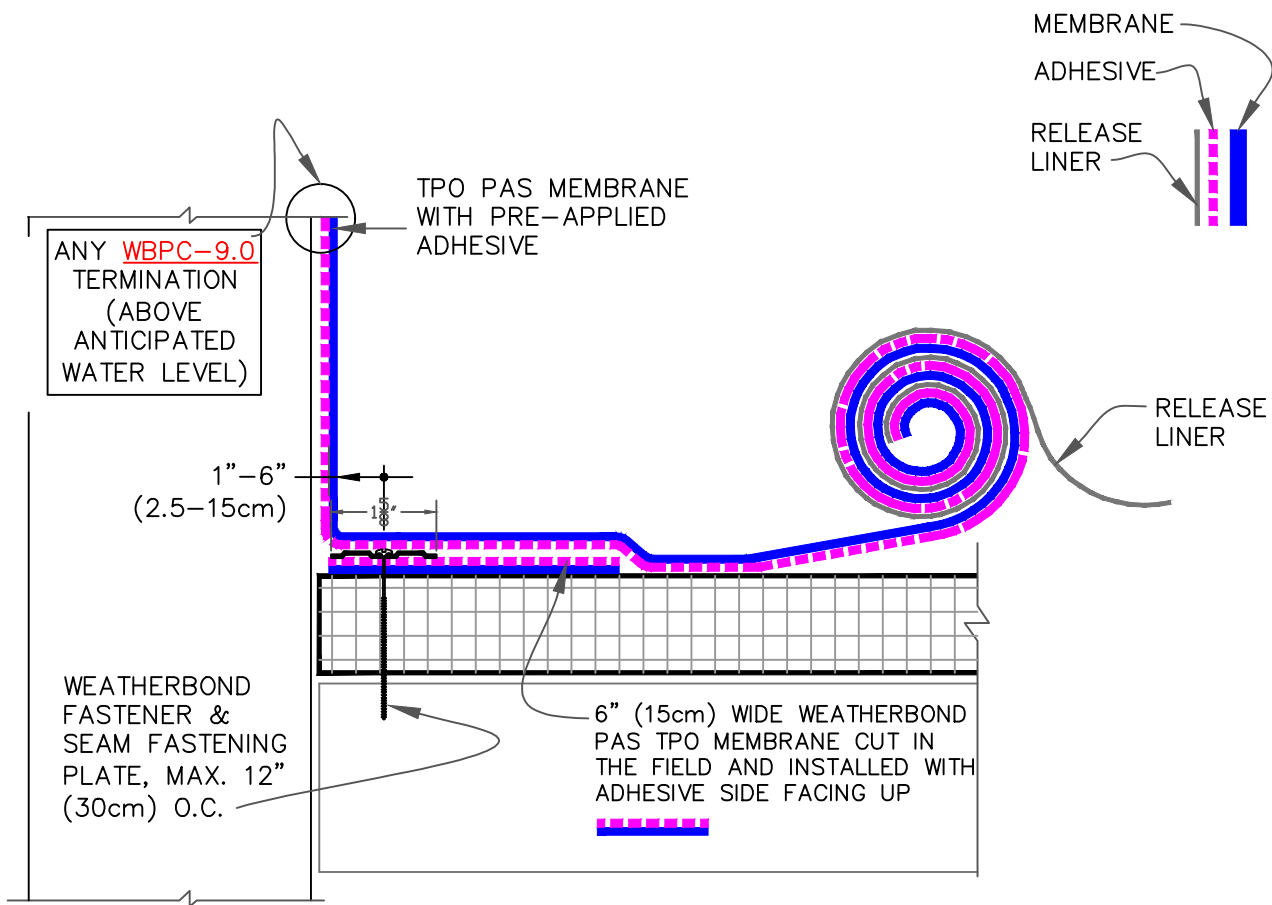

TPO WITH PAS (PEEL AND STICK) TECHNOLOGY



RPS (REINFORCED PERIMETER STRIP)



WEATHERBOND PAS
PARAPET FLASHING WITH
WEATHERBOND PAS RPS

-  TPO MEMBRANE
-  APPROVED SUBSTRATE
-  SEE NOTE

THERMOPLASTIC
ROOFING SYSTEM

WBPC-12.8

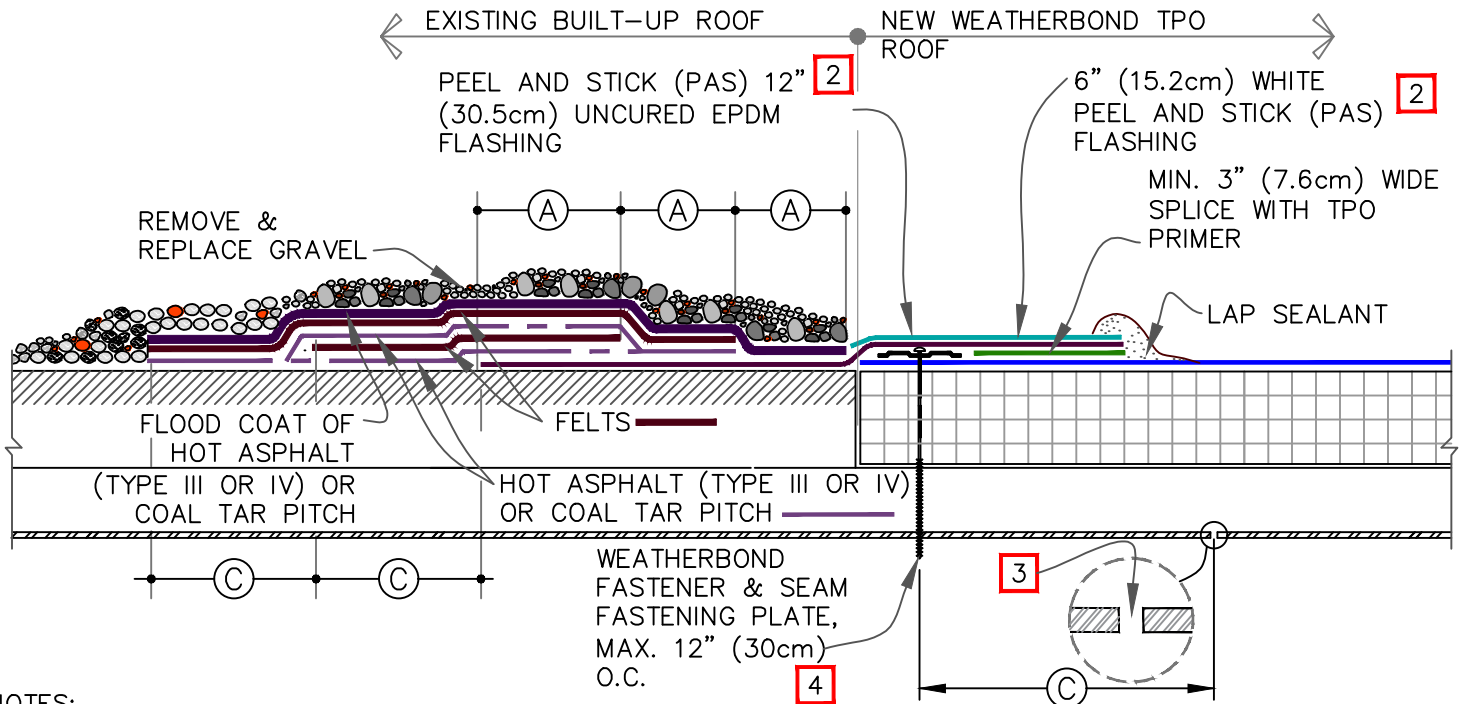

HOT TIE-IN OPTION

NOTES:

1. REMOVE ALL GRAVEL AT TIE-IN.
2. OVERLAY PEEL & STICK FLASHING WITH 6" (15cm) WHITE PEEL AND STICK FLASHING TO REDUCE HEAT GAIN ON TPO MEMBRANE
3. IF FLUTES ARE PERPENDICULAR TO THE TIE-IN DRILL A 3/8" (1cm) DIAMETER WEEP HOLE INTO THE BOTTOM FLUTES OF THE STEEL DECK ALONG THE PERIMETER OF THE TIE-IN 6" (15cm) MINIMUM TO 12" (30cm) MAXIMUM FROM THE SEAM FASTENING PLATE.
4. IF WATER PONDS OR FLOWS OVER TIE-IN FROM BUR SURFACE, USE [DETAIL WBPC-13.2](#).

FASTENER TYPES ON MECHANICALLY FASTENED ROOF ASSEMBLY			
DECK TYPE	OPTION	FASTENER	PLATE
STEEL	A	HPVX	HPVX
	B	HPV-XL	HPV-XL

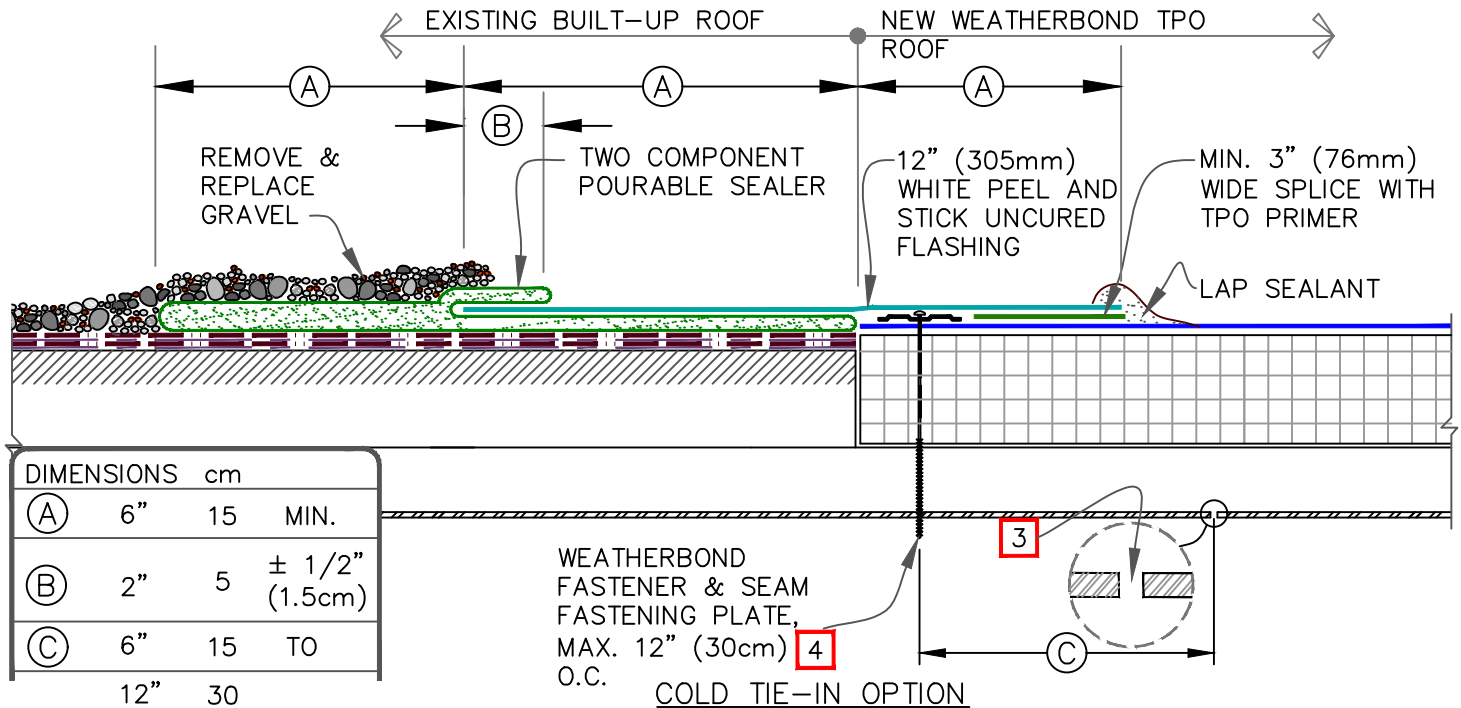

DIMENSIONS cm			
(A)	6"	15	MIN.
(B)	2"	5	± 1/2" (1.5cm)
(C)	6"	15	TO
	12"	30	

COLD TIE-IN OPTION



TPO TIE-IN TO BUILT-UP ROOFING OVER STEEL ROOF DECK

- TPO MEMBRANE
- APPROVED SUBSTRATE
- 0 SEE NOTE

THERMOPLASTIC ROOFING SYSTEM
WBPC-13.1

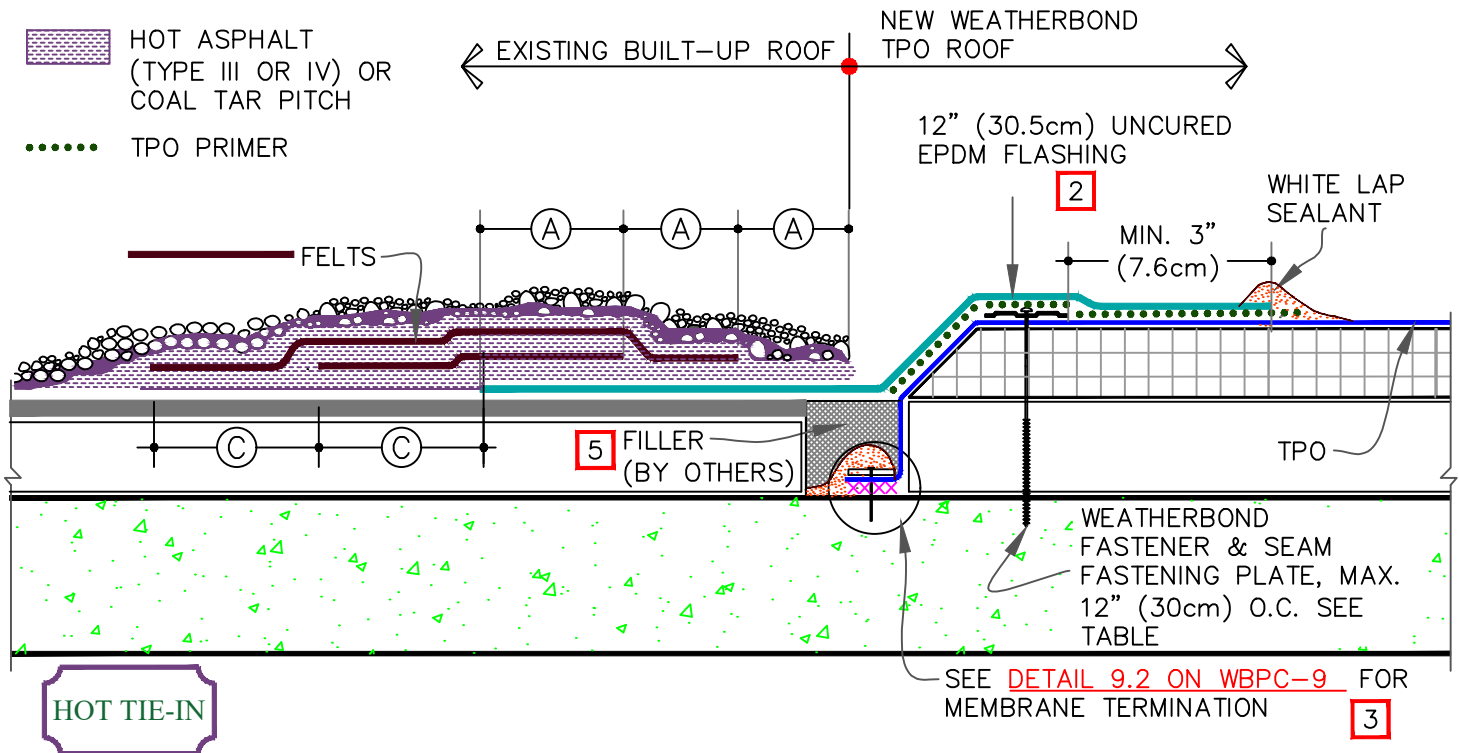

NOTES:

1. REMOVE ALL GRAVEL AT TIE-IN.
2. SPLICE TWO PIECES OF WHITE PRESSURE-SENSITIVE UNCURED FLASHING TOGETHER TO ACHIEVE DESIRED WIDTH.
3. WATER CUT-OFF MASTIC MUST BE HELD UNDER CONSTANT COMPRESSION.
4. WEATHERBOND IS NOT RESPONSIBLE FOR DAMAGE TO THE BUILT-UP ROOF OR STRUCTURAL DECK RESULTING FROM PONDED WATER; THIS DETAIL APPLIES TO RE-ROOFING WHEN A TEAR-OFF IS NOT SPECIFIED AND WAS DESIGNED TO PREVENT MIGRATION OF WATER WITHIN THE NEW ROOFING SYSTEM.
5. ACHIEVE SMOOTH SURFACE ON TOP.

FASTENER AND PLATE TYPE (STRUCTURAL CONCRETE DECK)			DIMENSIONS		cm
OPTION	FASTENER	PLATE	(A)	6"	15 MIN.
A	CD-10	HPWX	(B)	2"	±1/2"(1.5cm)
B	MP 14-10	HPWX	(C)	6"	15 MIN.
			(C)	12"	30 MAX.

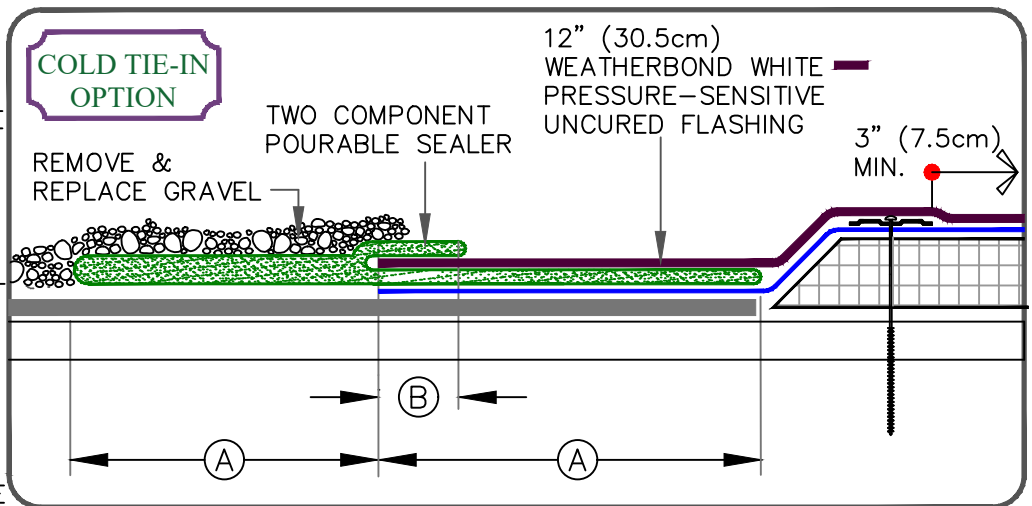

TPO TIE-IN TO BUILT-UP ROOFING OVER CONCRETE ROOF DECK

- TPO MEMBRANE
- APPROVED SUBSTRATE
- 0 —●— SEE NOTE

THERMOPLASTIC ROOFING SYSTEM

WBPC-13.2

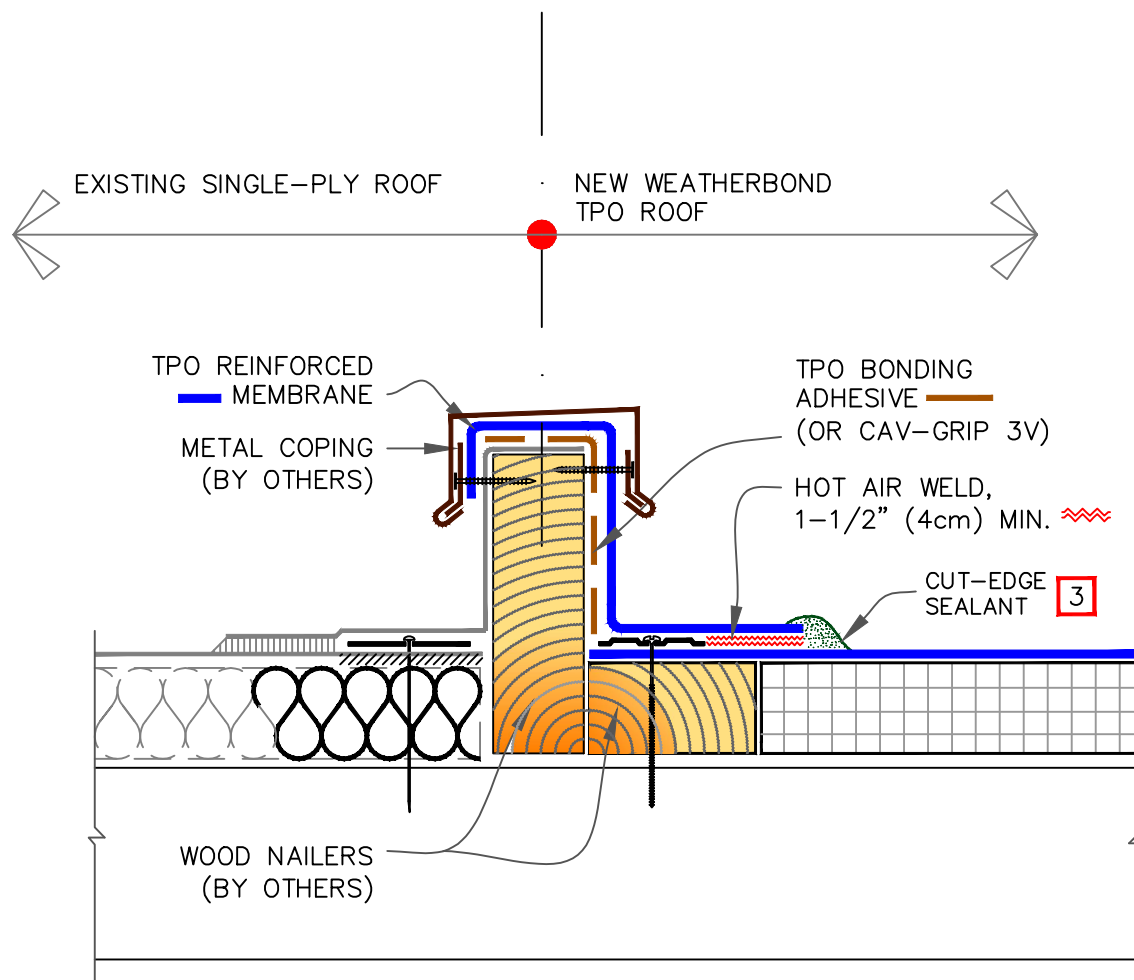

NOTES:

1. POSITION MEMBRANE FASTENING PLATES 1/2" (1.5cm) TO 1" (2.5cm) FROM EDGE OF DECK MEMBRANE.
2. ENSURE THE LOCATION OF CURB WILL NOT IMPEDE THE FLOW OF WATER AT EXISTING ADJACENT ROOF.
3. APPROXIMATELY 1/8" (0.5cm) DIAMETER BEAD OF CUT-EDGE SEALANT IS REQUIRED ON CUT EDGES OF REINFORCED TPO MEMBRANE.

..... EPDM / TPO PRIMER

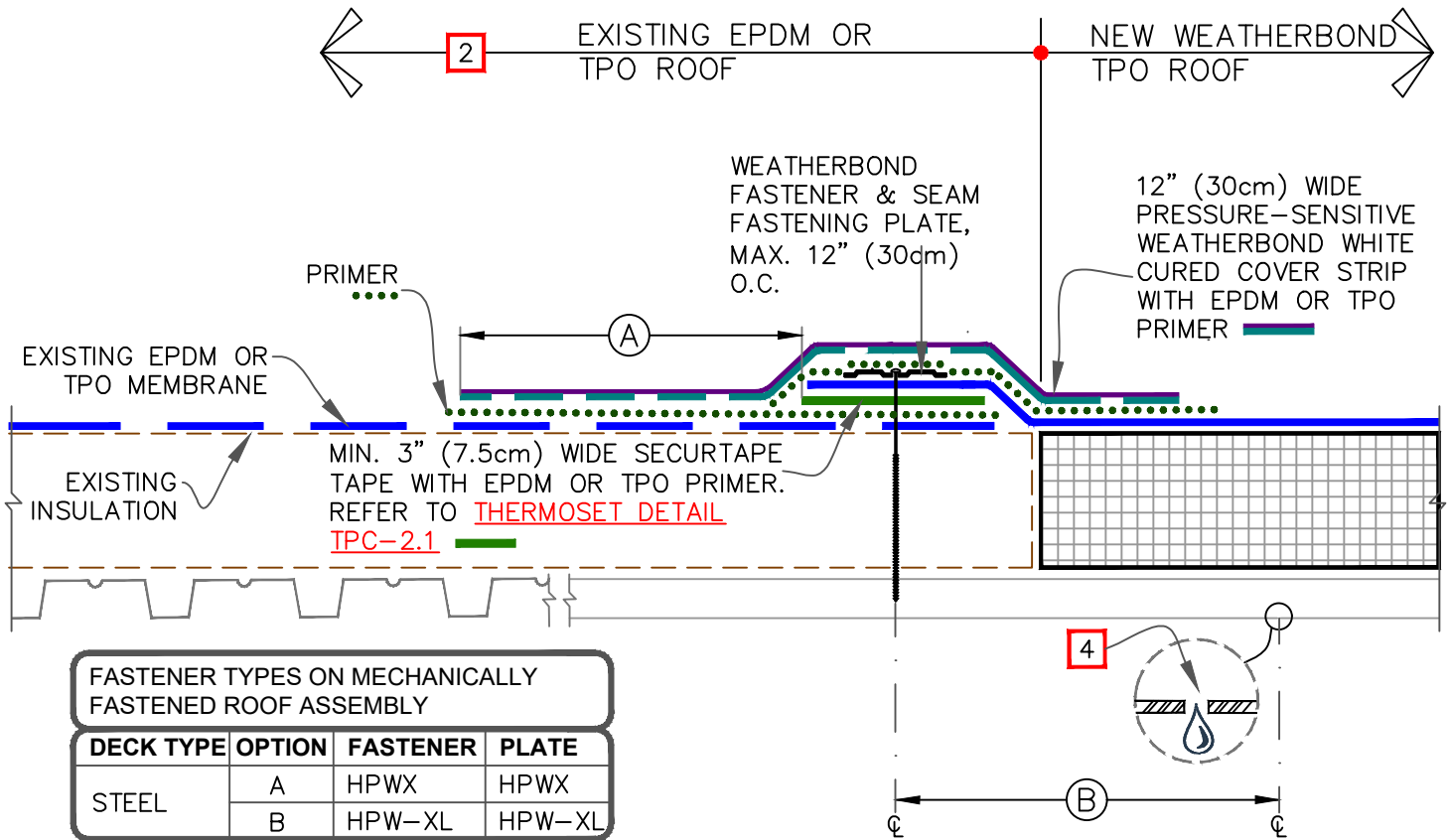

FASTENER TYPES ON MECHANICALLY FASTENED ROOF ASSEMBLY			
DECK TYPE	OPTION	FASTENER	PLATE
STEEL	A	HPWX	HPWX
	B	HPW-XL	HPW-XL

NOTES:

1. PRIOR TO SPLICING, CLEAN EXISTING EPDM OR TPO BY SCRUBBING THE SPLICE AREA WITH WEATHERED MEMBRANE CLEANER AND ALLOW TO DRY.
2. CONTACT MANUFACTURER OF EXISTING WARRANTED MEMBRANE ROOFING SYSTEM TO VERIFY ACCEPTANCE OF TIE-IN.
3. FOR EXISTING BALLASTED SYSTEMS BY OTHERS, CONSULT RESPECTIVE MANUFACTURER FOR ACCEPTABLE GRAVEL CONTAINMENT TO PREVENT GRAVEL MIGRATION.
4. IF FLUTES ARE PERPENDICULAR (AS DEPICTED), DRILL A 3/8" (1cm) DIAMETER WEEP HOLE INTO THE BOTTOM FLUTES OF THE STEEL DECK ALONG THE PERIMETER OF THE TIE-IN 6" (15cm) MINIMUM TO 12" (30cm) MAXIMUM FROM THE SEAM FASTENING PLATE. HOLES MAY NOT BE REQUIRED IF DECK SLOPES DOWN TOWARDS EXISTING ROOF.

DIMENSIONS		cm	
(A)	6"	15	
(B)	6"	15	MIN.
(B)	12"	30	MAX.

FASTENER & PRESSURE PLATE TYPES FOR DIFFERENT ROOF DECKS			
DECK TYPE	OPTION	FASTENER	PLATE
STEEL OR WOOD	A	HPWX	HPWX
	B	HPW-XL	HPW-XL
STRUCTURAL CONCRETE	A	CD-10	HPWX
	B	MP 14-10	HPWX



TPO TIE-IN TO EXISTING EPDM MEMBRANE

—●— TPO MEMBRANE
 —●— APPROVED SUBSTRATE
0 —●— SEE NOTE

THERMOPLASTIC ROOFING SYSTEM

WBPC-13.4

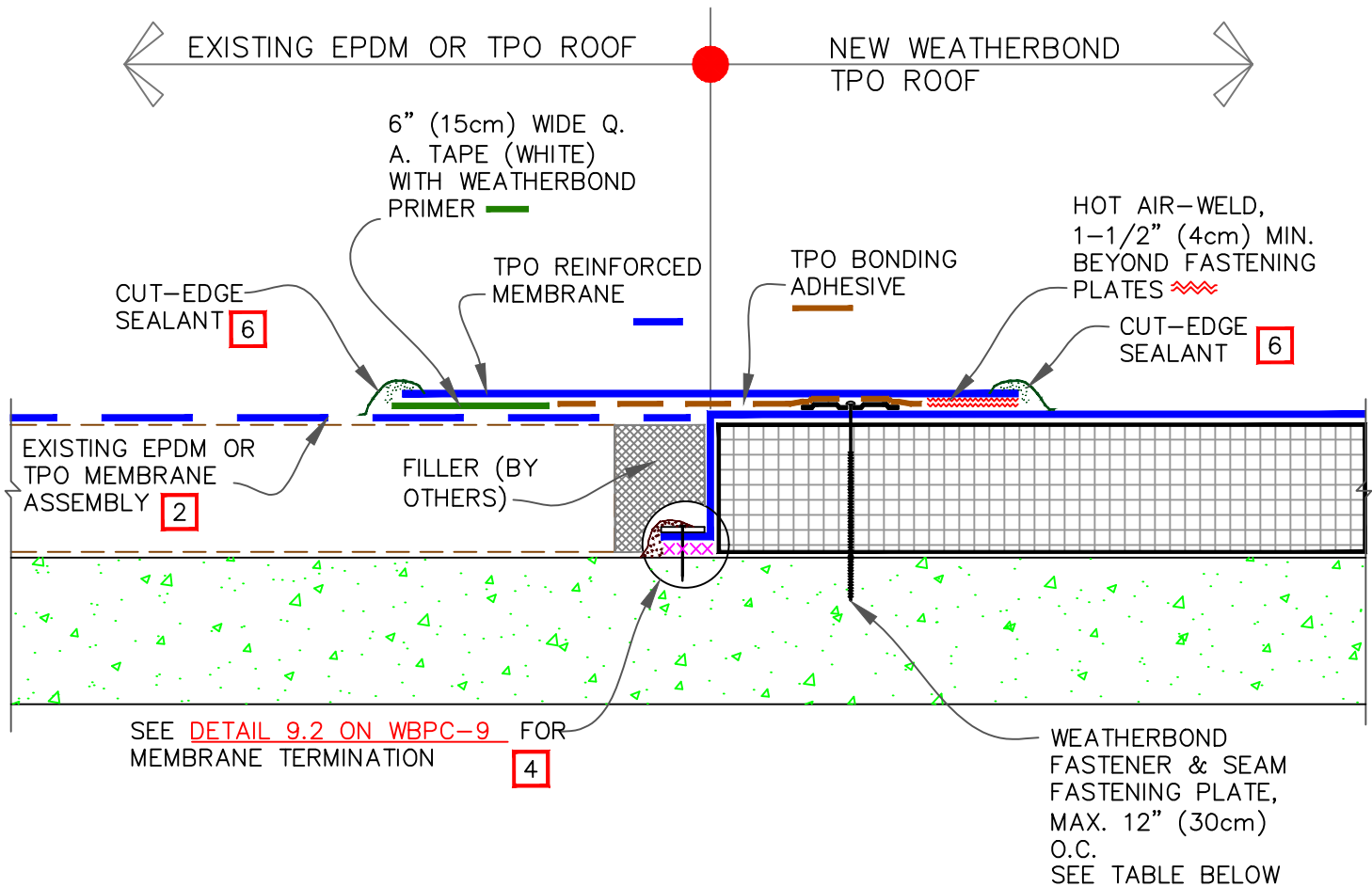

NOTES:

1. PRIOR TO SPLICING, CLEAN EXISTING EPDM OR TPO MEMBRANE BY SCRUBBING THE SPLICE AREA WITH WEATHERED MEMBRANE CLEANER AND ALLOW TO DRY.
2. CONTACT MANUFACTURER OF EXISTING WARRANTED MEMBRANE ROOFING SYSTEM TO VERIFY ACCEPTANCE OF TIE-IN.
3. ON EXISTING BALLASTED SYSTEMS, CONSULT RESPECTIVE MANUFACTURER FOR ACCEPTABLE GRAVEL CONTAINMENT TO PREVENT GRAVEL MIGRATION.
4. WATER CUT-OFF MASTIC MUST BE HELD UNDER CONSTANT COMPRESSION.
5. WHEN RE-ROOFING OVER PRE-CAST CONCRETE, APPLY LIBERAL BEAD OF WATER CUT-OFF MASTIC IN THE JOINTS TO PREVENT MOISTURE MIGRATION.
6. APPROXIMATELY 1/8" (0.5cm) DIAMETER BEAD OF CUT-EDGE SEALANT IS REQUIRED ON CUT EDGES OF REINFORCED TPO MEMBRANE.

FASTENER TYPES

DECK TYPE	OPTION	FASTENER	PLATE
STRUCTURAL CONCRETE	A	CD-10	HPVX
	B	MP 14-10	HPVX



EPDM TIE-IN ON CONCRETE DECK

—● TPO MEMBRANE
 —● APPROVED SUBSTRATE
 —● SEE NOTE

THERMOPLASTIC ROOFING SYSTEM

WBPC-13.5

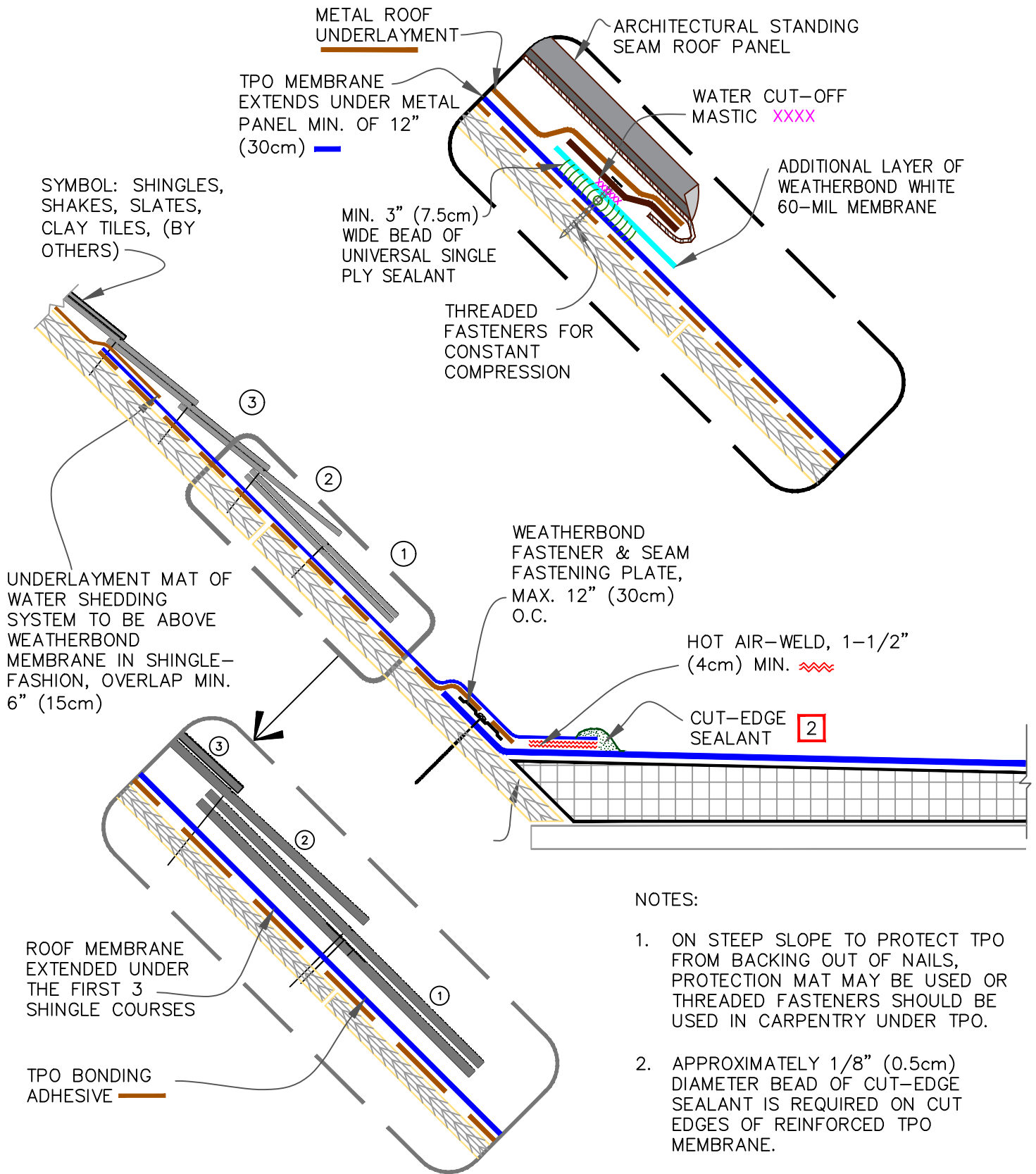

TPO/PVC TIE-IN TO SHINGLED ROOF

- ● TPO MEMBRANE
- APPROVED SUBSTRATE
- 0 ● SEE NOTE

OTHER THERMOPLASTIC ROOFING SYSTEM

WBPC-13.6

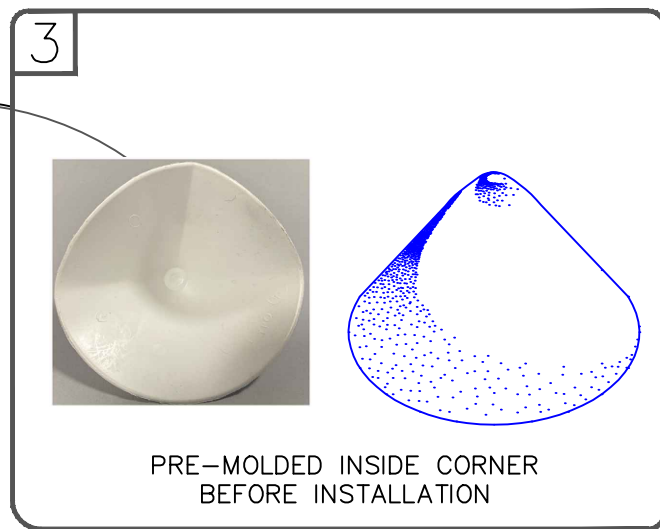
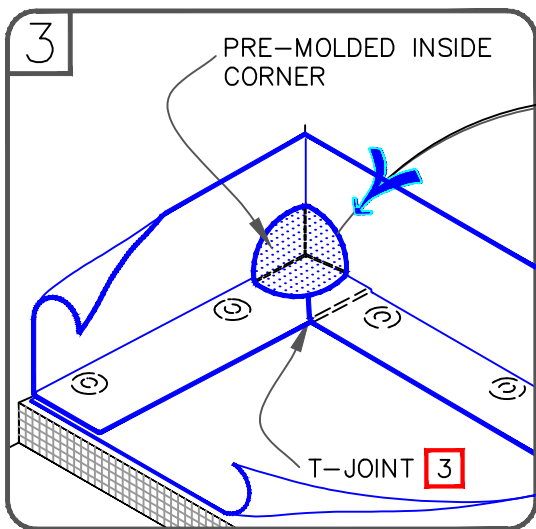
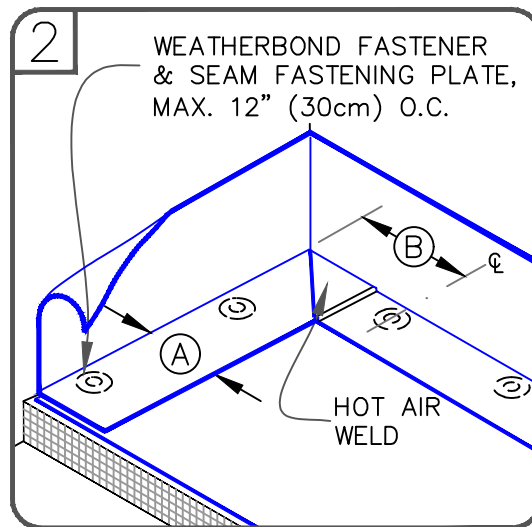
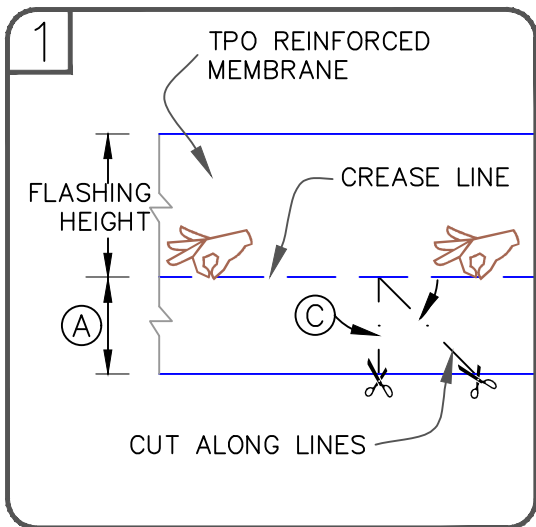

NOTES:

1. POSITION FASTENING PLATES 6" TO 9" (15 TO 23cm) FROM THE CORNER AND 1/2" TO 1" (1.5 TO 2.5cm) FROM EDGE OF MEMBRANE.
2. REFER TO WEATHERBOND SPECIFICATIONS FOR ACCEPTABLE WEATHERBOND FASTENERS AND PLATES.
3. WHEN USING 60-MIL TPO OR 80-MIL, APPLY A 4-1/2" (11.5cm) DIAMETER "T-JOINT" COVER AT ALL FIELD SPLICE INTERSECTIONS.
4. APPROXIMATELY 1/8" (0.5cm) DIAMETER BEAD OF CUT-EDGE SEALANT IS REQUIRED ON CUT EDGES OF REINFORCED TPO MEMBRANE.

DIMENSIONS	cm	
(A)	6"	15 APPROX.
(B)	6"-9"	15-23
(C)	45-DEGREES APPROX.	



PRE-MOLDED INSIDE CORNER FLASHING

- TPO MEMBRANE
- APPROVED SUBSTRATE
- SEE NOTE

THERMOPLASTIC ROOFING SYSTEM

WBPC-15.1

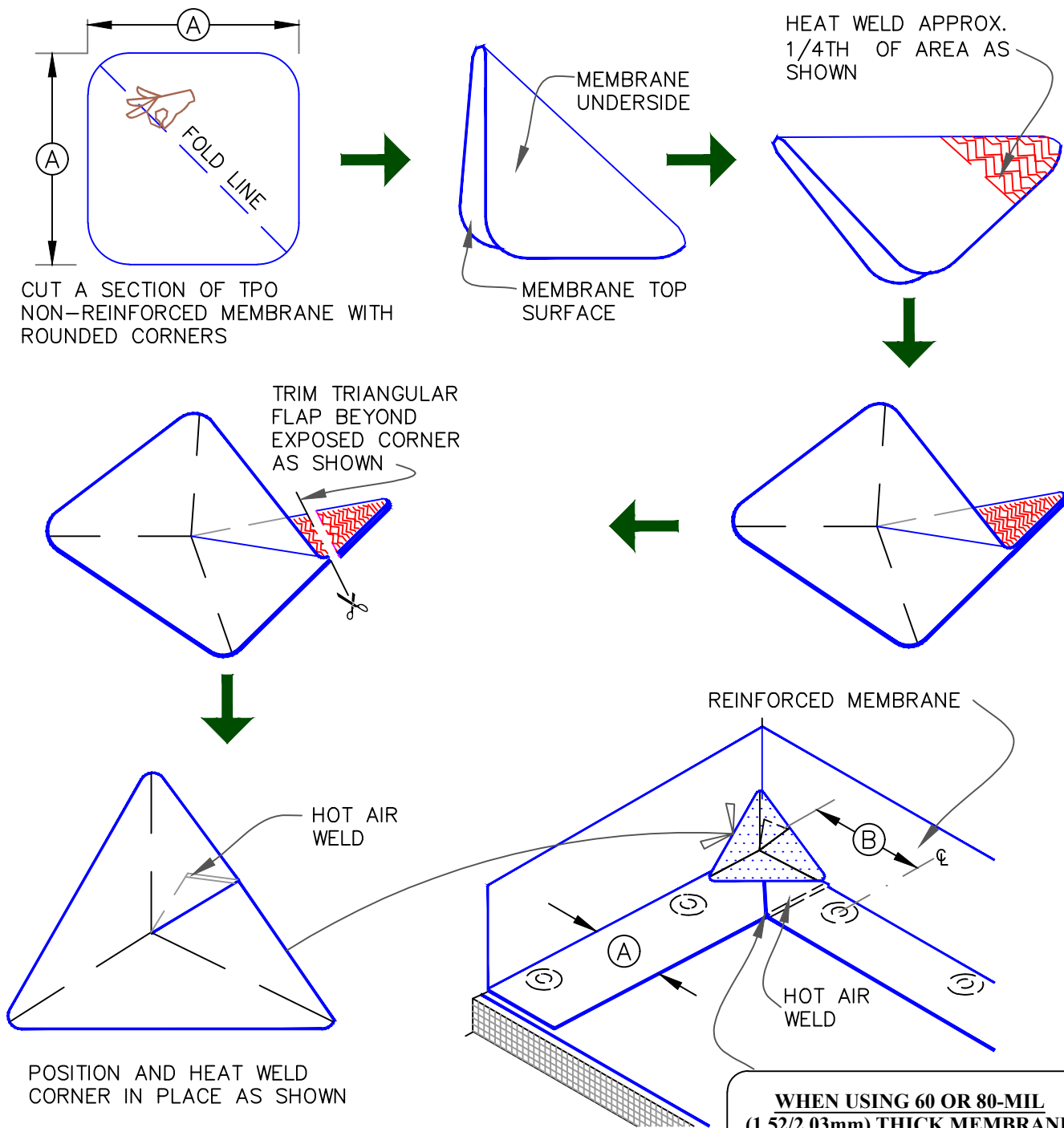

WHEN USING 60 OR 80-MIL (1.52/2.03mm) THICK MEMBRANE
 APPLY A 4-1/2" (11.8cm) DIAMETER "T-JOINT" COVER AT FIELD SPLICE INTERSECTIONS, CENTRALLY ALIGNED.

DIMENSIONS	cm	
(A)	6"	15 APPROX.
(B)	6"-9"	15-23



FIELD FABRICATED INSIDE CORNER FLASHING

- TPO MEMBRANE
- APPROVED SUBSTRATE
- 0 SEE NOTE

THERMOPLASTIC ROOFING SYSTEM

WBPC-15.2

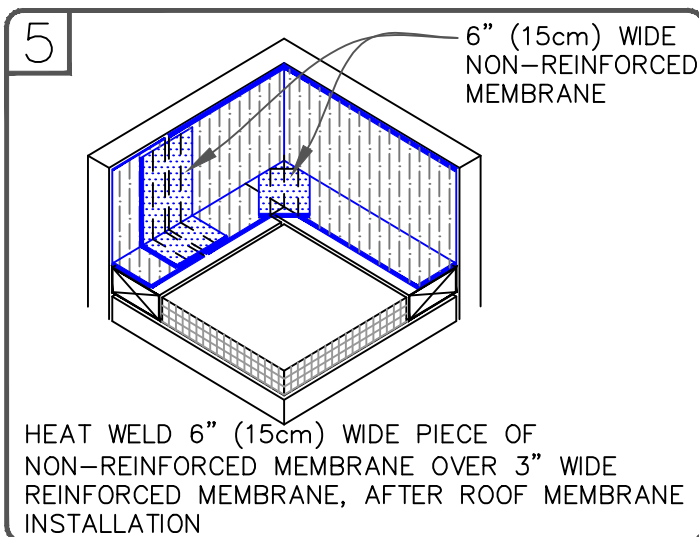
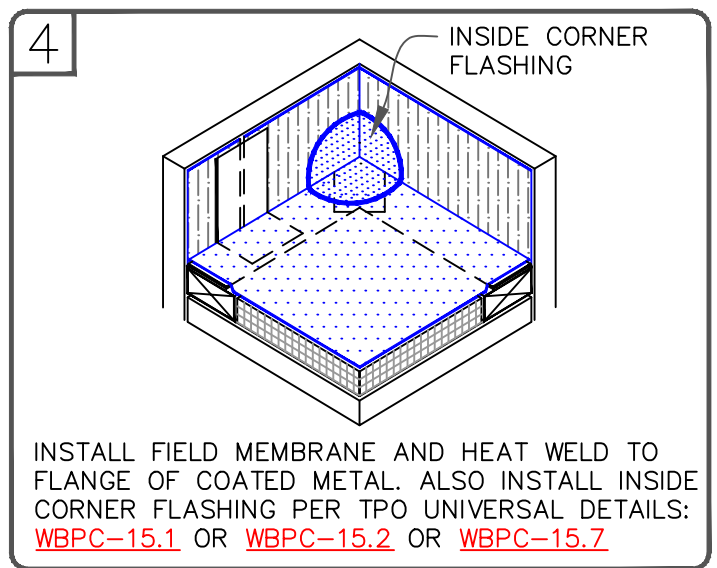
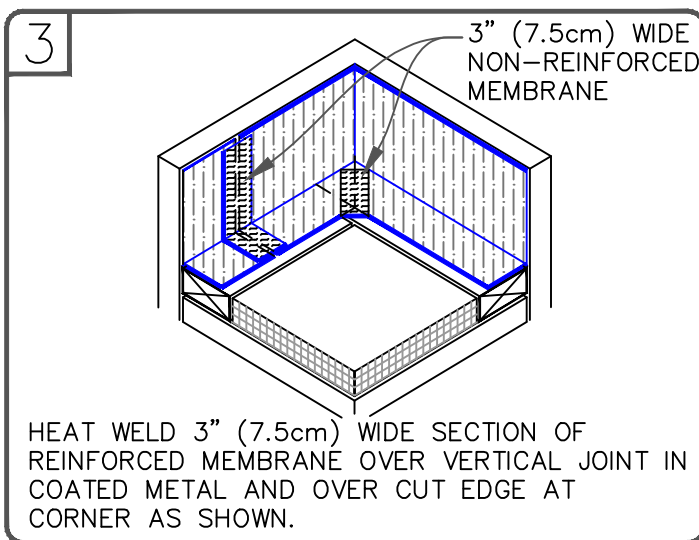
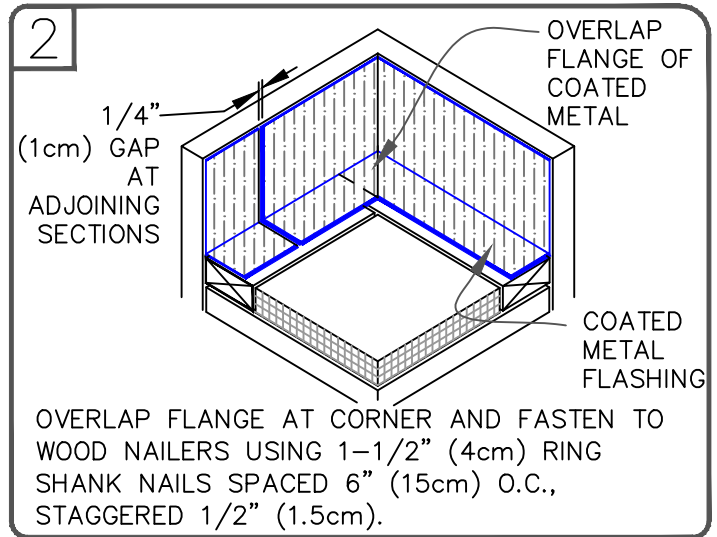
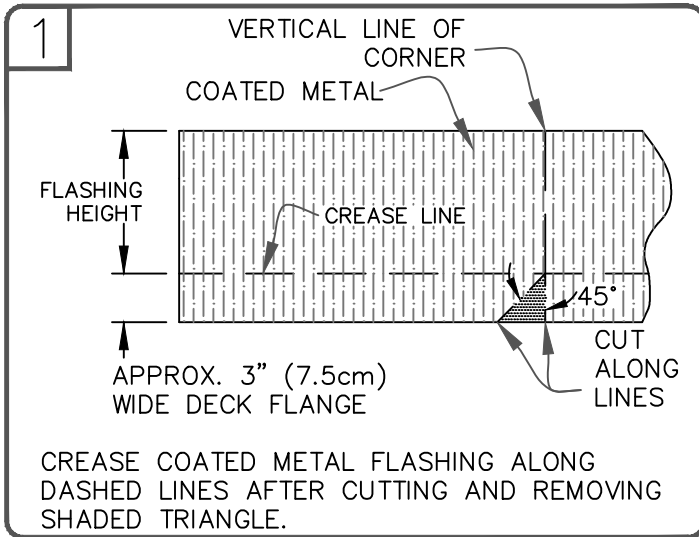

- SEQUENCE:**
1. 3" (7.6cm) REINFORCED MEMBRANE STRIPPING.
 2. FIELD MEMBRANE.
 3. TOP 6" (15.2cm) NON-REINFORCED MEMBRANE STRIPPING.

- NOTES:**
1. FASTEN COATED METAL FLASHING TO WOOD NAILERS USING 1-1/2" (4cm) MIN. RING SHANK NAILS SPACED 6" (15cm) ON CENTER AND STAGGERED APPROX. 1/2" (1.5cm).
 2. COORDINATE THIS DETAIL WITH [WBPC-12.3](#) FOR ADDITIONAL INFORMATION.
 3. APPROXIMATELY 1/8" (0.5cm) DIAMETER BEAD OF CUT-EDGE SEALANT IS REQUIRED ON CUT EDGES OF REINFORCED TPO MEMBRANE.



INSIDE CORNER WITH COATED METAL WALL FLASHING

- TPO MEMBRANE
- APPROVED SUBSTRATE
- SEE NOTE

THERMOPLASTIC ROOFING SYSTEM

WBPC-15.3

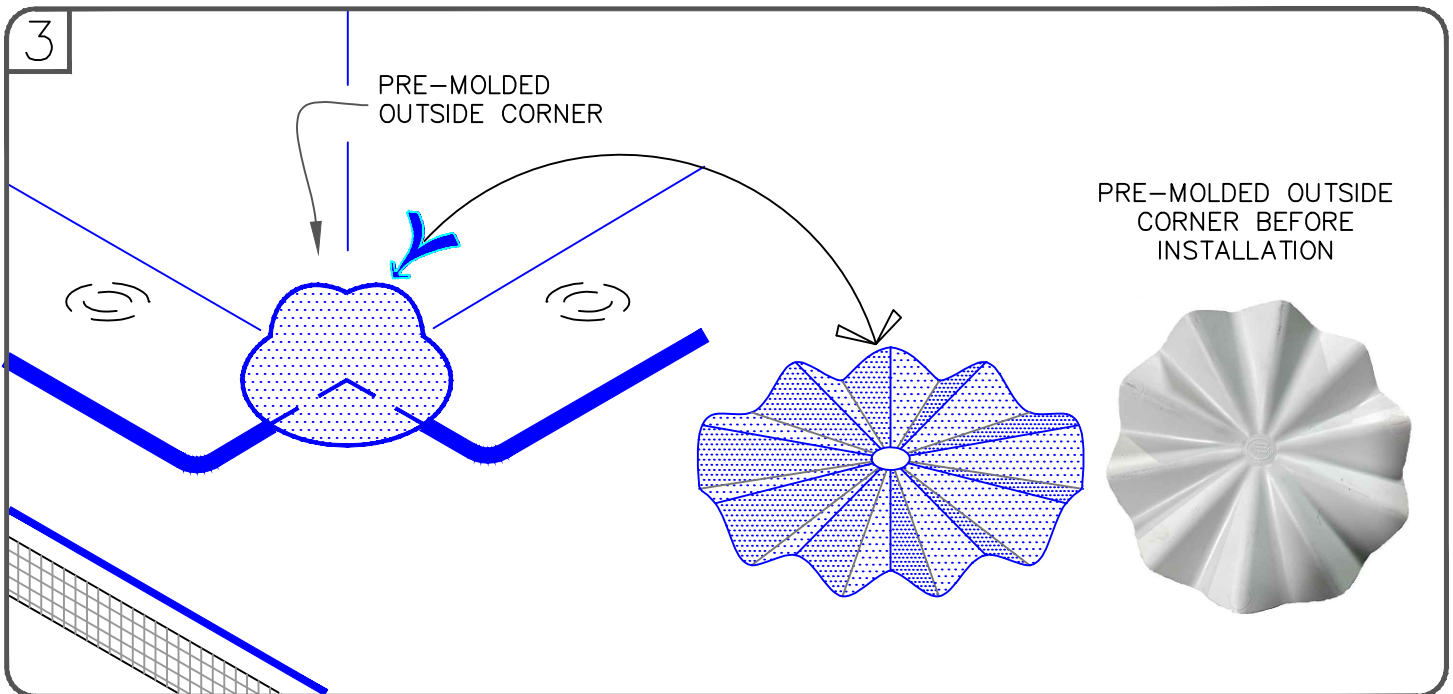
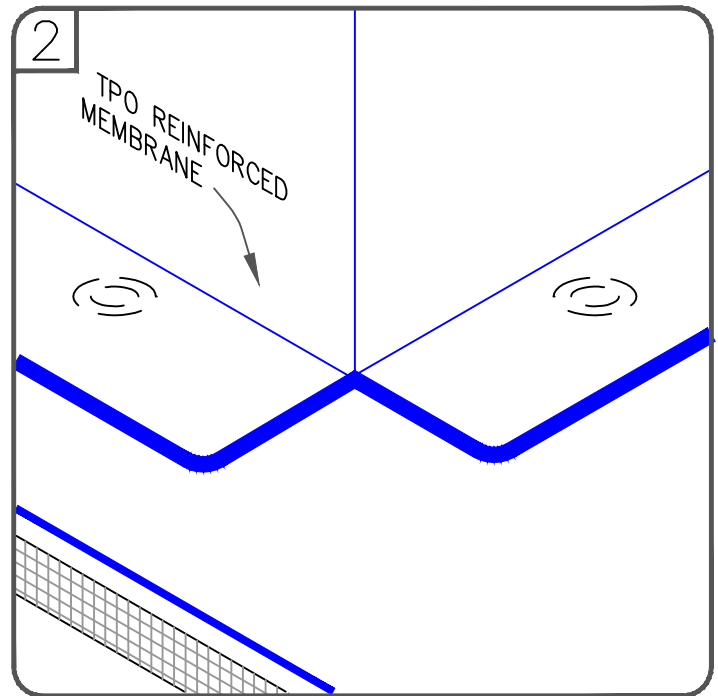
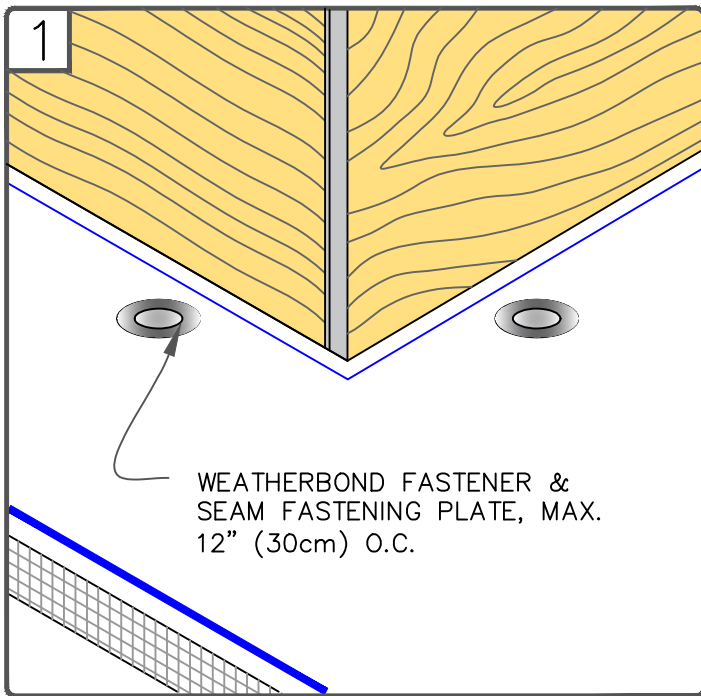

NOTES:

1. POSITION FASTENING PLATES 6"(15cm) FROM THE CORNER AND 1/2" TO 1" (1.5 TO 2.5cm) FROM EDGE OF MEMBRANE.
2. REFER TO WEATHERBOND SPECIFICATIONS FOR ACCEPTABLE WEATHERBOND FASTENERS AND PLATES.
3. APPROXIMATELY 1/8" (0.5cm) DIAMETER BEAD OF CUT-EDGE SEALANT IS REQUIRED ON CUT EDGES OF REINFORCED TPO MEMBRANE.

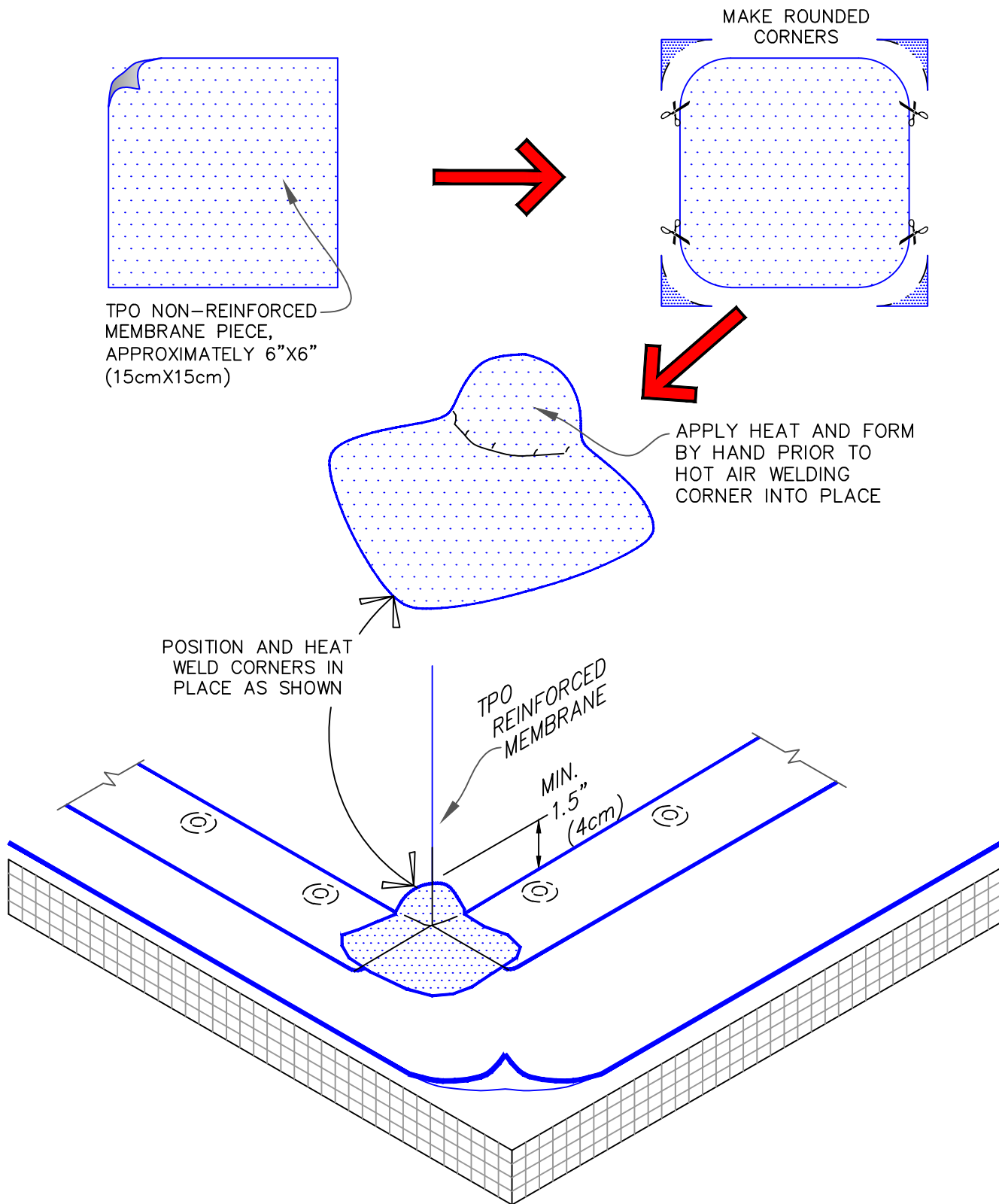

FIELD FABRICATED OUTSIDE CORNER FLASHING

- TPO MEMBRANE
- APPROVED SUBSTRATE
- SEE NOTE

THERMOPLASTIC ROOFING SYSTEM

WBPC-15.5

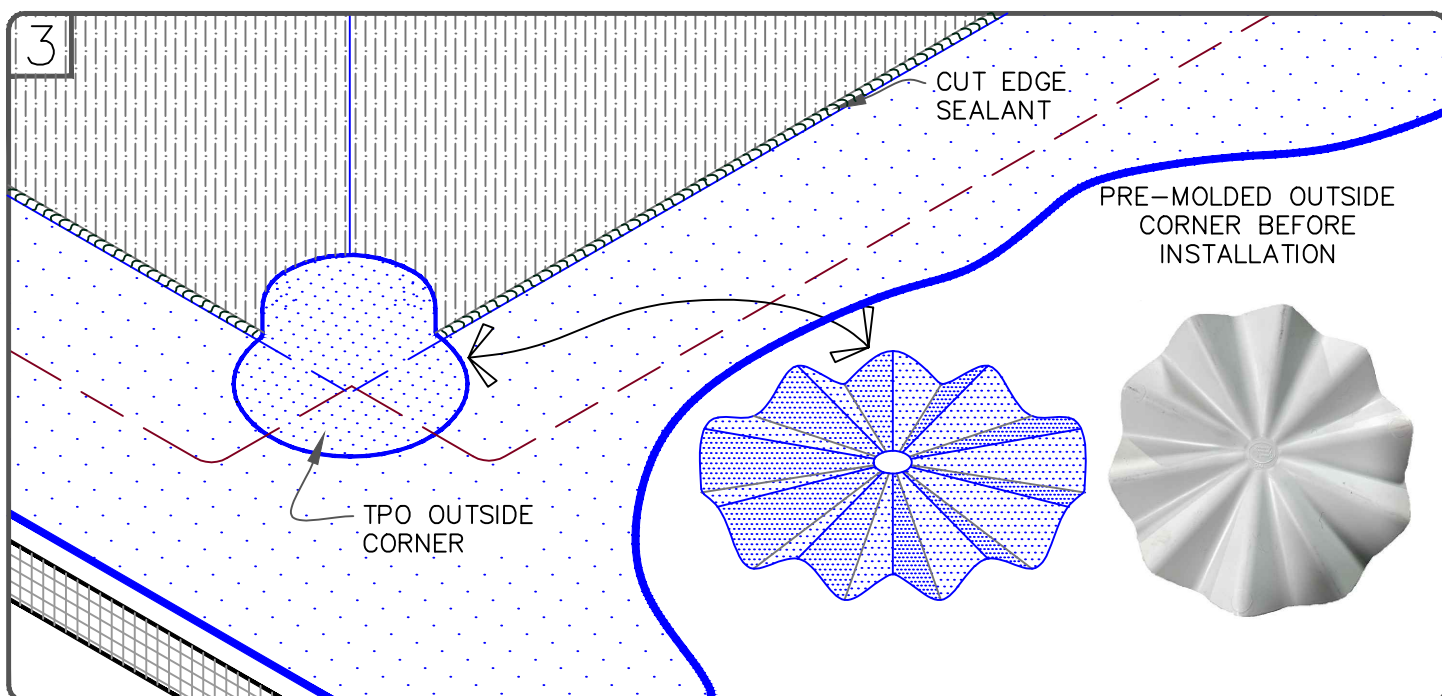
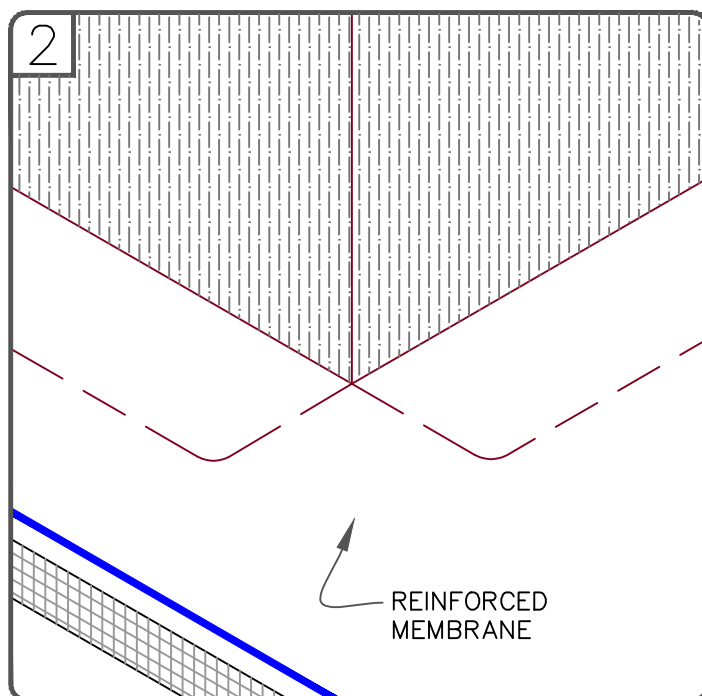
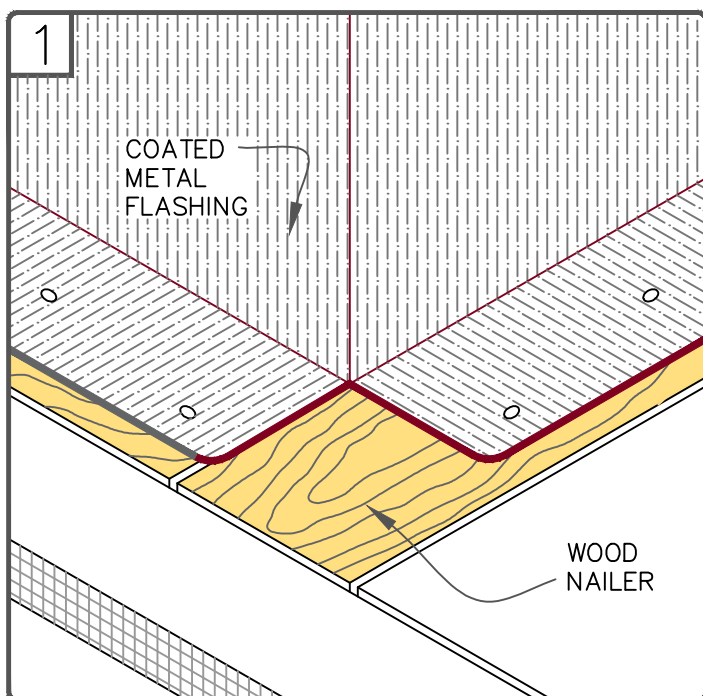

NOTES:

1. FASTEN COATED METAL FLASHING TO WOOD NAILERS USING 1-1/2" (4cm) MIN. RING SHANK NAILS SPACED 6" (15cm) ON CENTER AND STAGGERED APPROX. 1/2" (1.5cm).
2. REFER TO TPO DETAIL [WBPC-5.2](#) FOR FLASHING VERTICAL JOINTS IN COATED METAL.

60-MIL THICK TPO,
UNIVERSAL CORNERS CAN
BE USED FOR 3 DIFFERENT
CORNER CONDITIONS AS
SHOWN BELOW

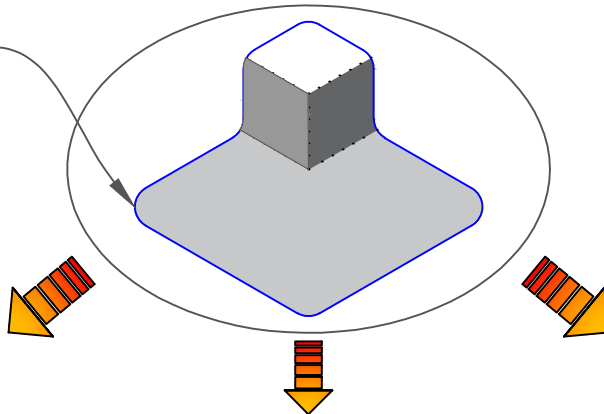

OPTION A

OPTION B

OPTION C

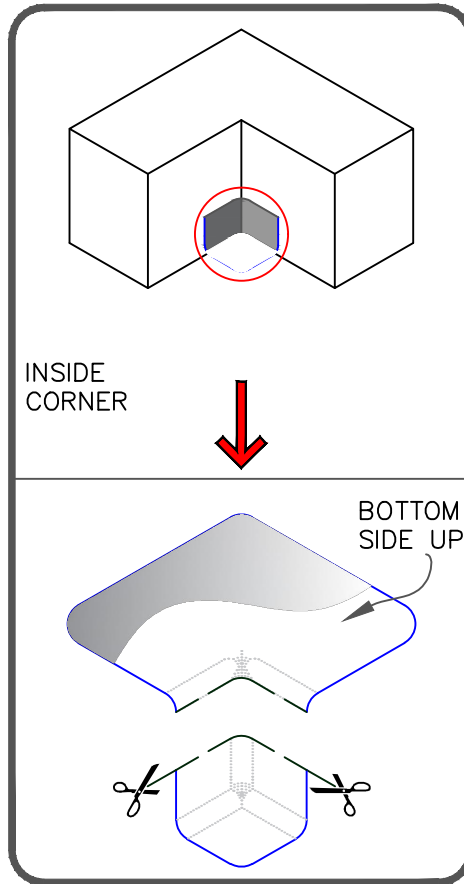
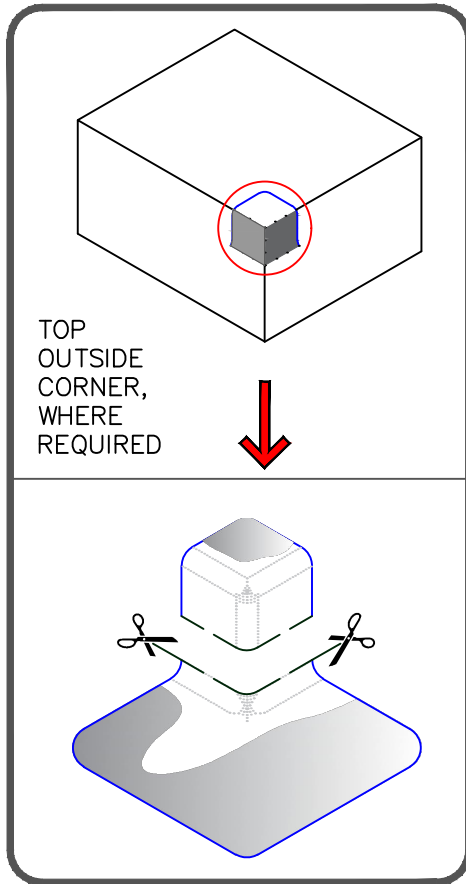
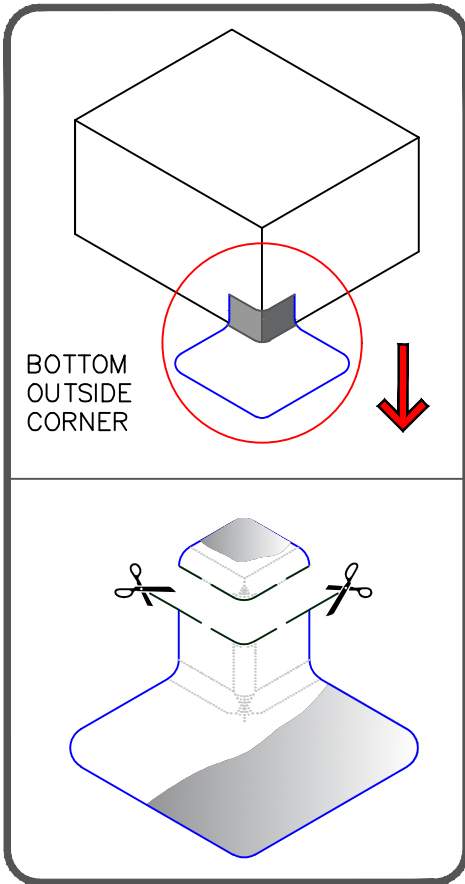

NOTES:

1. ROOF SYSTEMS MUST NOT HAVE FIELD FABRICATED OR BUILT-IN CANT STRIP.
2. REFER TO TECHNICAL DATA BULLETINS FOR COLOR AVAILABILITY.

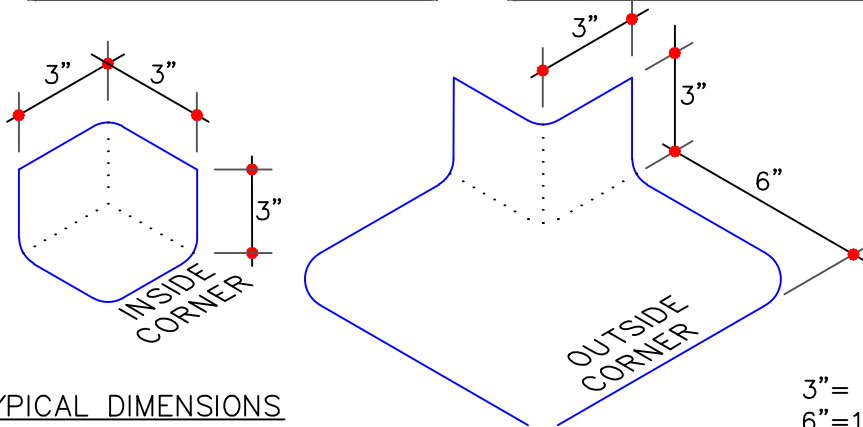

TYPICAL DIMENSIONS

3" = 7.5cm
6" = 15cm



PVC OR TPO:
UNIVERSAL CORNERS –
COMBINATION INSIDE &
OUTSIDE CORNERS

- TPO MEMBRANE
- APPROVED SUBSTRATE
- SEE NOTE

THERMOPLASTIC
ROOFING SYSTEM
WBPC-15.7

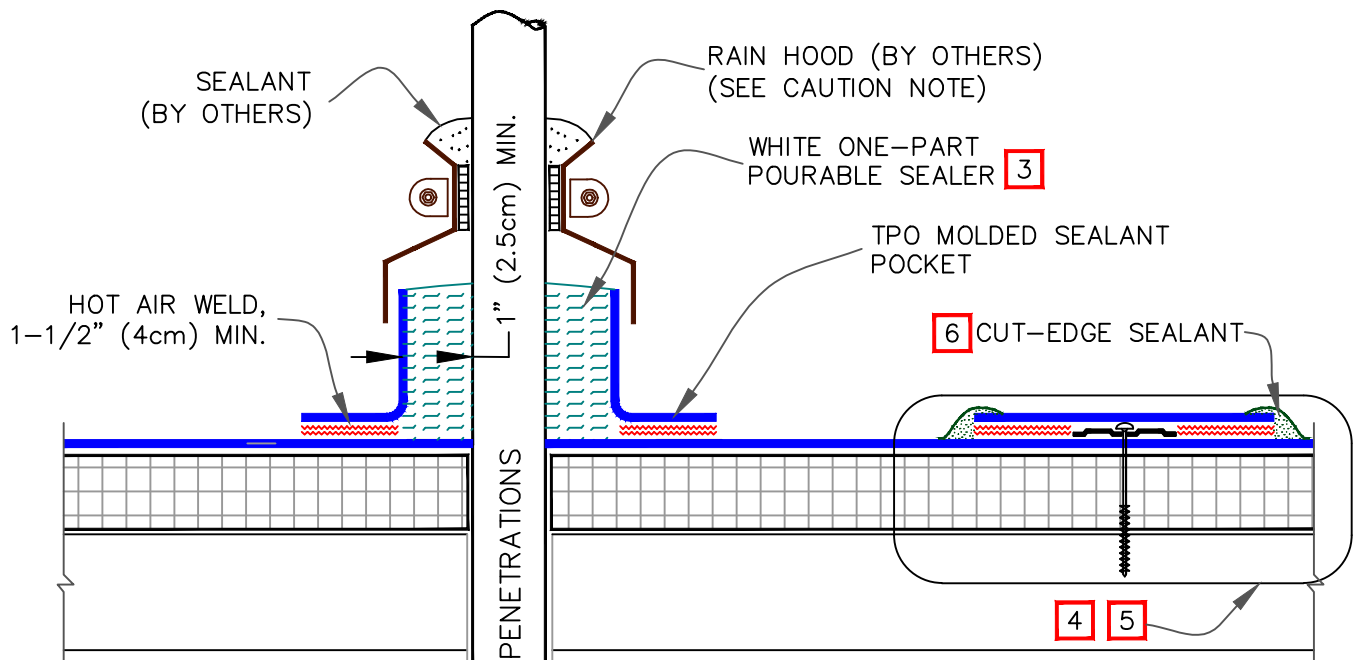

NOTES:

1. TEMPERATURE OF PIPE MUST NOT EXCEED 160° F (71° C).
2. WHEN USING TPO MOLDED SEALANT POCKET, TPO PRIMER MUST BE APPLIED TO ALL INSIDE SURFACES AND PENETRATIONS PRIOR TO FILLING WITH SEALANT.
3. FILL POCKET COMPLETELY WITH WHITE ONE-PART POURABLE SEALER UNTIL RIM IS COVERED WITH SEALANT; ENSURE ALL VOIDS ARE FILLED.
4. ON MECHANICALLY-ATTACHED SYSTEMS, INSTALL A MINIMUM OF 4 FASTENING PLATES AROUND SEALANT POCKETS WITH A DIAMETER UP TO 6" (15cm). ADDITIONAL FASTENING PLATES WILL BE REQUIRED FOR SEALANT POCKETS GREATER THAN 6" IN DIAMETER AND SHALL BE SPACED 12" (30cm) ON CENTER MAXIMUM.
5. REFER TO WEATHERBOND SPECIFICATIONS FOR PROPER FASTENERS AND PLATES.
6. APPROXIMATELY 1/8" (0.5cm) DIAMETER BEAD OF CUT-EDGE SEALANT IS REQUIRED ON CUT EDGES OF REINFORCED TPO MEMBRANE.

PLACE MOLDED TPO SEALANT POCKET AROUND PENETRATION AND OVERLAP THE TWO SECTIONS

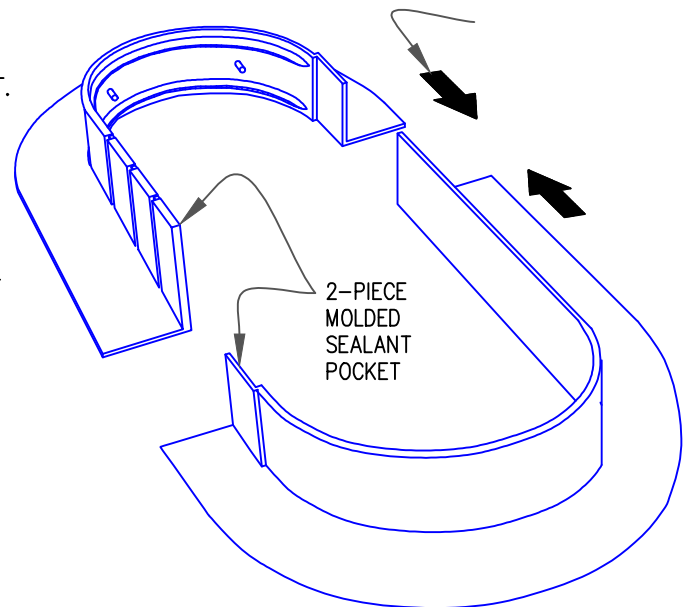

REFER TO PRODUCT DATA SHEET FOR STEP-BY-STEP INSTALLATION PROCEDURES



MOLDED SEALANT POCKET

- TPO MEMBRANE
- APPROVED SUBSTRATE
- SEE NOTE

THERMOPLASTIC ROOFING SYSTEM

WBPC-16.1

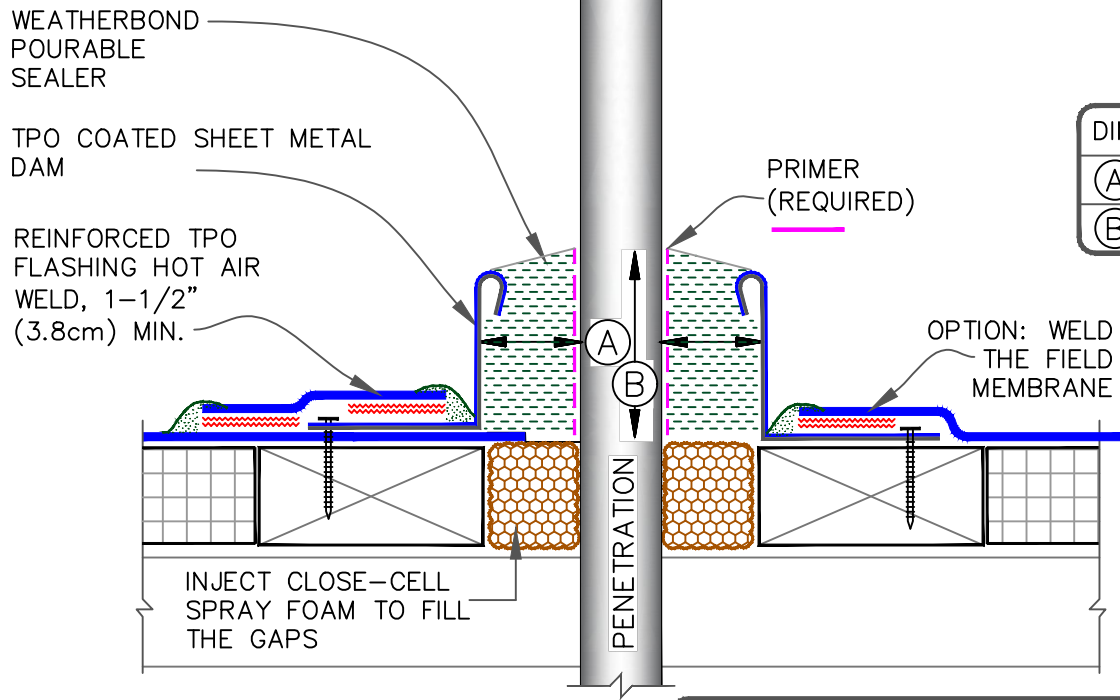

DIMENSIONS	cm	
(A)	1"	2.5 MIN.
(B)	2.5"	5 MIN.

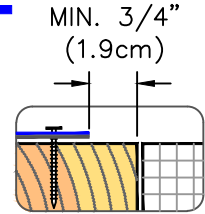

SEQUENCE:

1. REINFORCED MEMBRANE STRIPPING.
2. FIELD MEMBRANE.
3. TOP UN-REINFORCED MEMBRANE STRIPPING.

NOTES:

1. TEMPERATURE OF PENETRATIONS MUST NOT EXCEED 160° F (71° C).
2. TPO PRIMER MUST BE APPLIED TO ALL INSIDE SURFACES AND PENETRATIONS PRIOR TO FILLING WITH SEALANT..
3. FILL POCKET COMPLETELY WITH WHITE ONE-PART POURABLE SEALER UNTIL RIM IS COVERED WITH SEALANT; ENSURE ALL VOIDS ARE FILLED.
4. ON MECHANICALLY-ATTACHED SYSTEMS, INSTALL A MINIMUM OF 4 FASTENING PLATES AROUND SEALANT POCKETS WITH A DIAMETER UP TO 6" (152mm). ADDITIONAL FASTENING PLATES WILL BE REQUIRED FOR SEALANT POCKETS GREATER THAN 6" IN DIAMETER AND SHALL BE SPACED 12" (305mm) ON CENTER MAXIMUM. FASTENERS/PLATES ARE NOT REQUIRED ON ADHERED SYSTEMS UNLESS SEALANT POCKET DIAMETER EXCEEDS 12" (305mm).
5. REFER TO WEATHERBOND SPECIFICATIONS FOR PROPER TYPES OF FASTENERS AND PLATES.

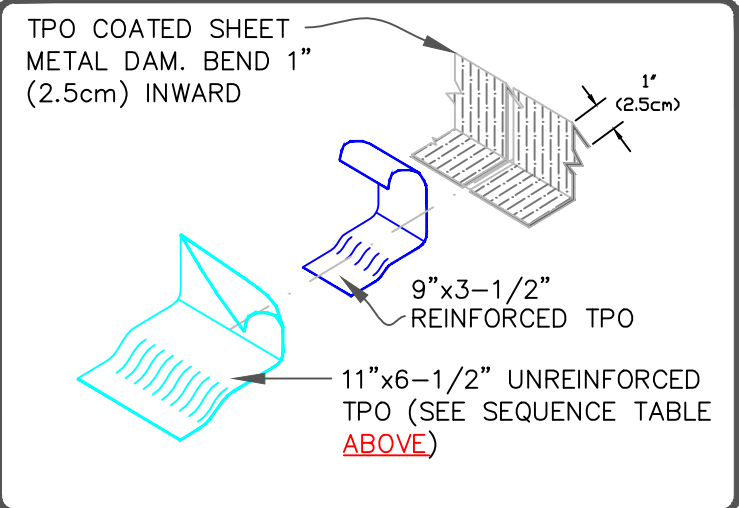
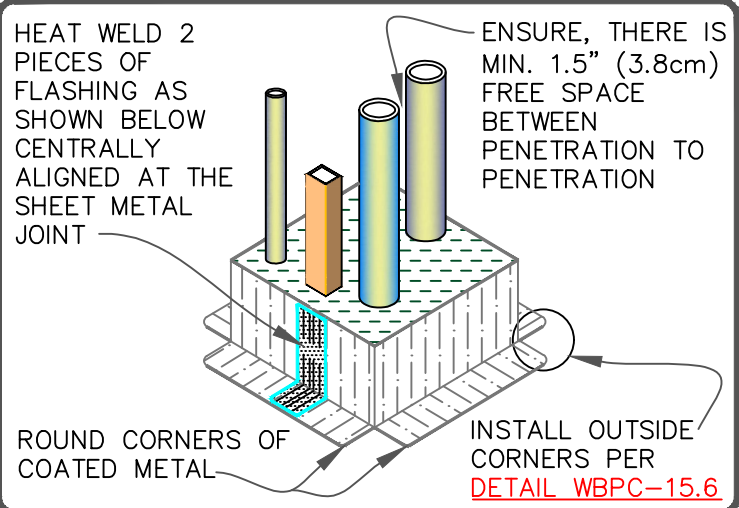

FIELD FABRICATED TPO COATED METAL POCKET

- TPO MEMBRANE
- APPROVED SUBSTRATE
- SEE NOTE

THERMOPLASTIC ROOFING SYSTEM
WBPC-16.2

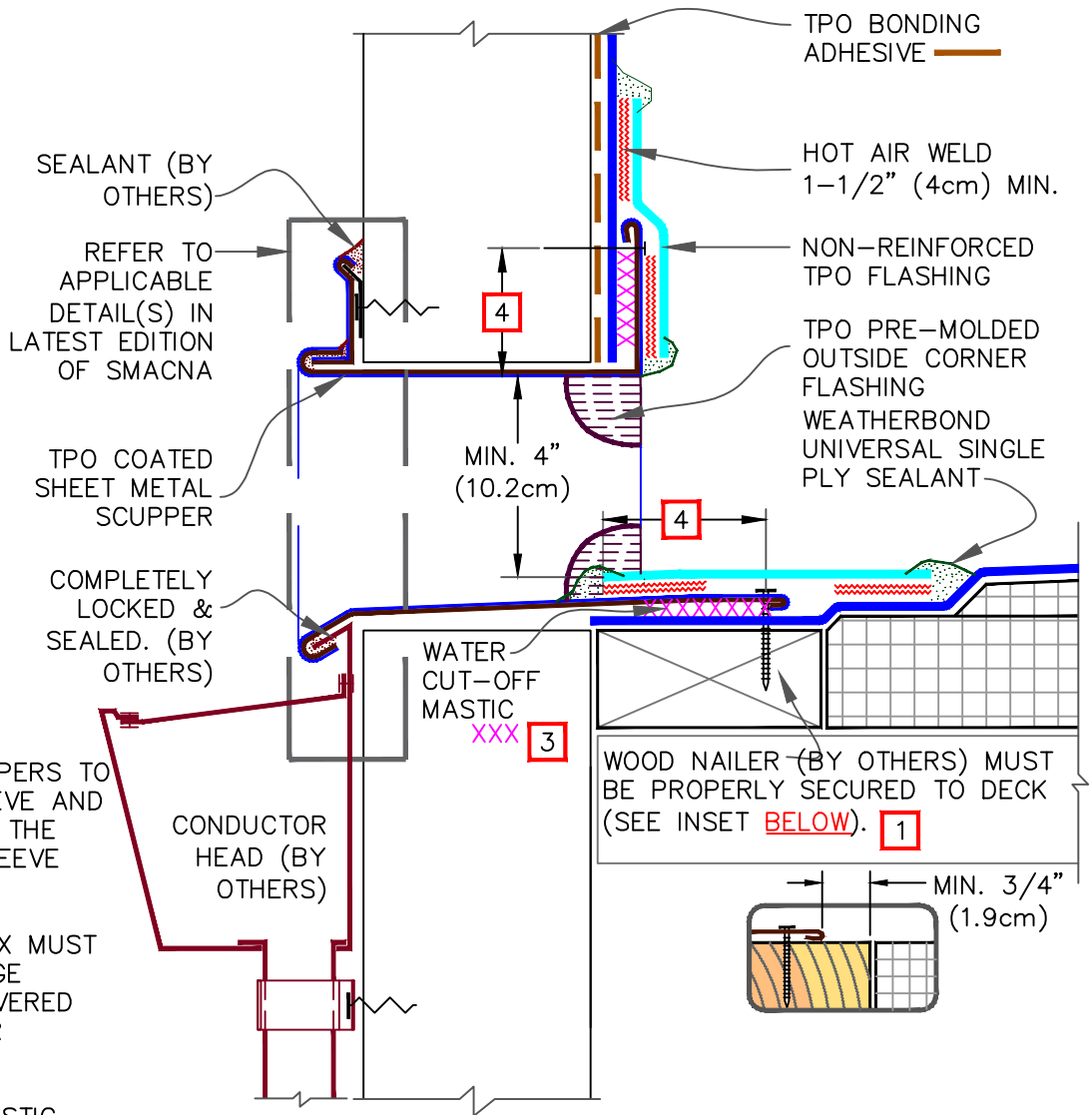

NOTES:

1. WOOD NAILERS ARE INSTALLED AT SCUPPERS TO SECURE METAL SLEEVE AND MUST EXTEND PAST THE WIDTH OF METAL SLEEVE FLANGE.
2. METAL SCUPPER BOX MUST HAVE FOLDED FLANGE CORNERS FULLY COVERED BY OUTSIDE CORNER FLASHING.
3. WATER CUT-OFF MASTIC UNDER SCUPPER FLANGES MUST BE UNDER CONSTANT COMPRESSION.
4. SCUPPER FLANGES MUST BE TOTALLY COVERED BY NON-REINFORCED FLASHING WITH MINIMUM 2" (5cm) COVERAGE PAST NAIL HEAD.

WOOD NAILER (BY OTHERS) MUST BE PROPERLY SECURED TO DECK (SEE INSET BELOW). **1**

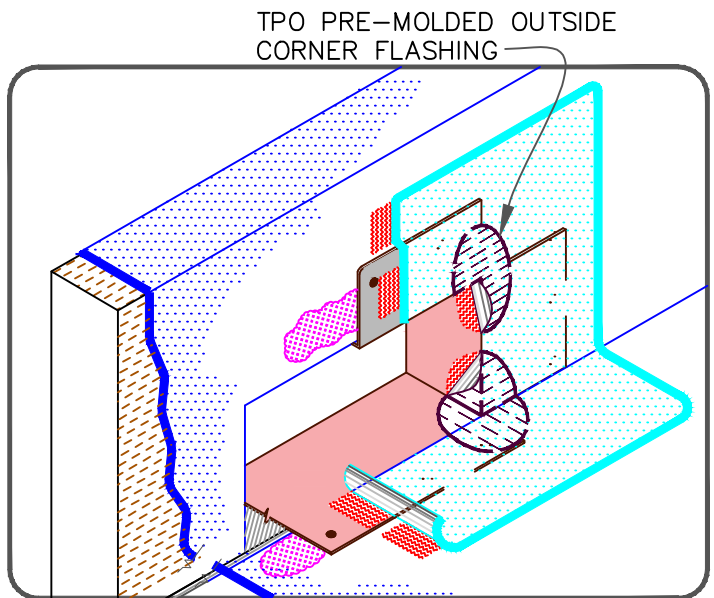
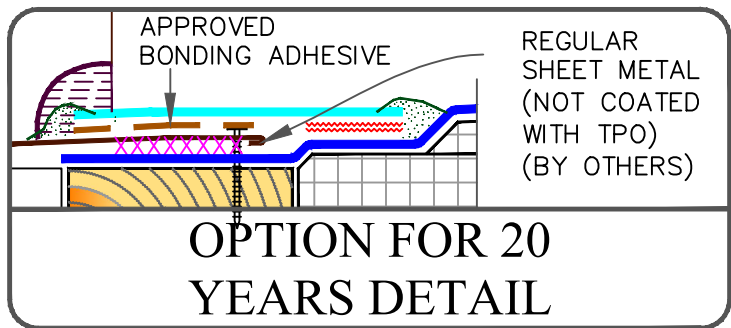
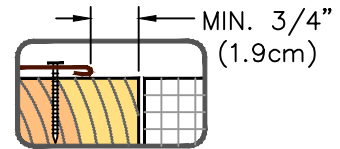

SCUPPER WITH COATED METAL

- ● TPO MEMBRANE
- APPROVED SUBSTRATE
- 0 ● SEE NOTE

THERMOPLASTIC ROOFING SYSTEM

WBPC-18.1

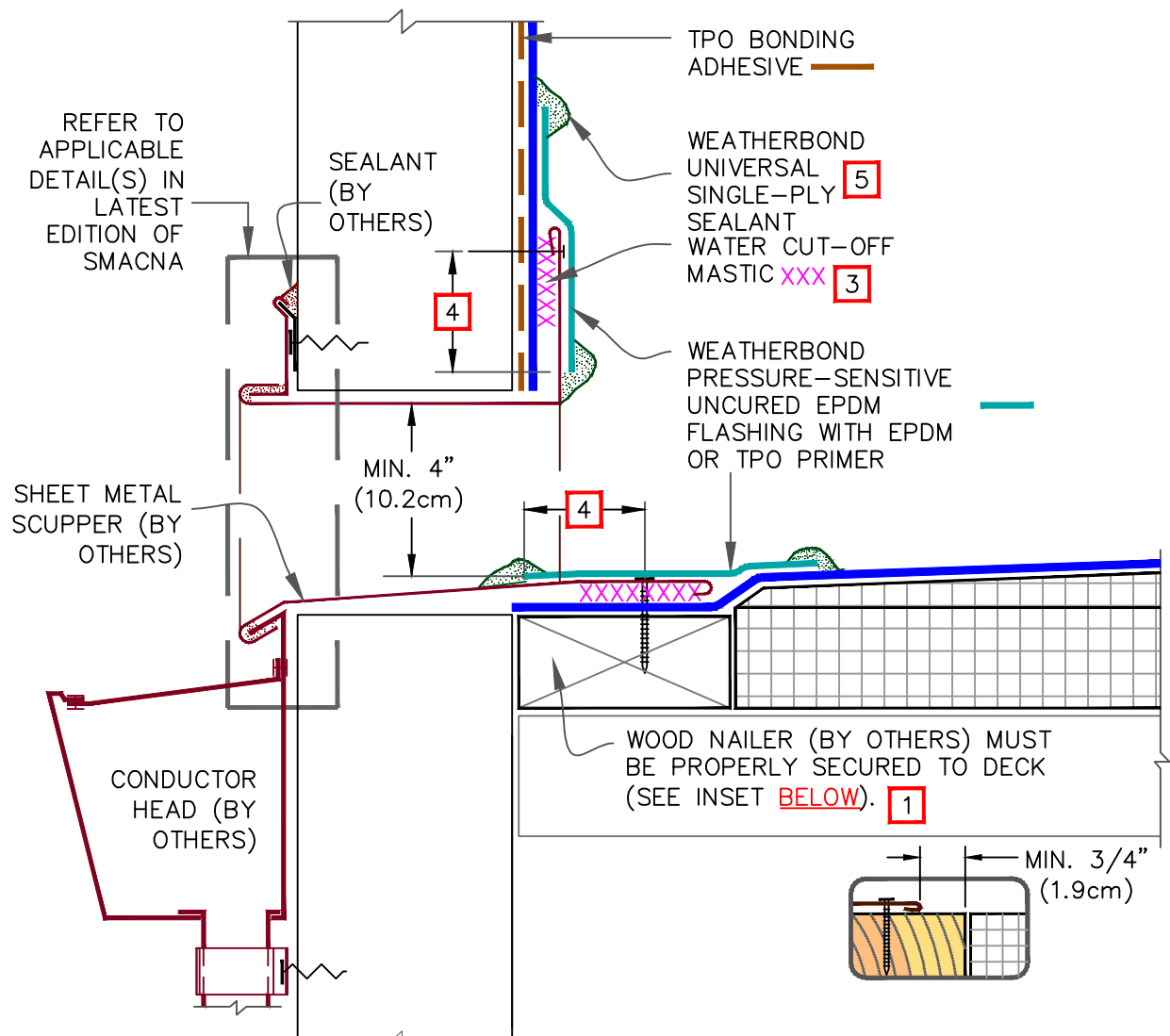

NOTES:

1. WOOD NAILERS ARE INSTALLED AT SCUPPERS TO SECURE METAL SLEEVE AND MUST EXTEND PAST THE WIDTH OF METAL SLEEVE FLANGE.
2. METAL SCUPPER BOX MUST HAVE CONTINUOUS FLANGES WITH ROUNDED CORNERS, SOLDER ALL SCUPPER SEAMS WATER-TIGHT.
3. WATER CUT-OFF MASTIC UNDER SCUPPER FLANGES MUST BE UNDER CONSTANT COMPRESSION.
4. SCUPPER FLANGES MUST BE TOTALLY COVERED BY PRESSURE-SENSITIVE UNCURED FLASHING WITH MINIMUM 2" (5cm) COVERAGE PAST NAIL HEAD.
5. UNIVERSAL SINGLE-PLY SEALANT IS REQUIRED AT FLASHING EDGES ON SCUPPER EDGE. TPO PRIMER MUST BE USED TO PREPARE SURFACES PRIOR TO THE APPLICATION OF SEALANT.

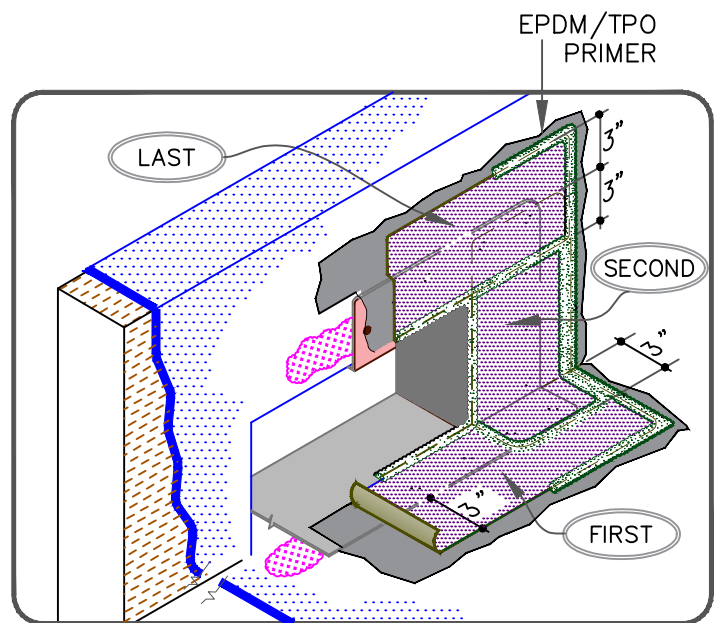

SCUPPER AT DECK-TPO

- TPO MEMBRANE
- APPROVED SUBSTRATE
- 0 SEE NOTE

THERMOPLASTIC ROOFING SYSTEM

WBPC-18.2

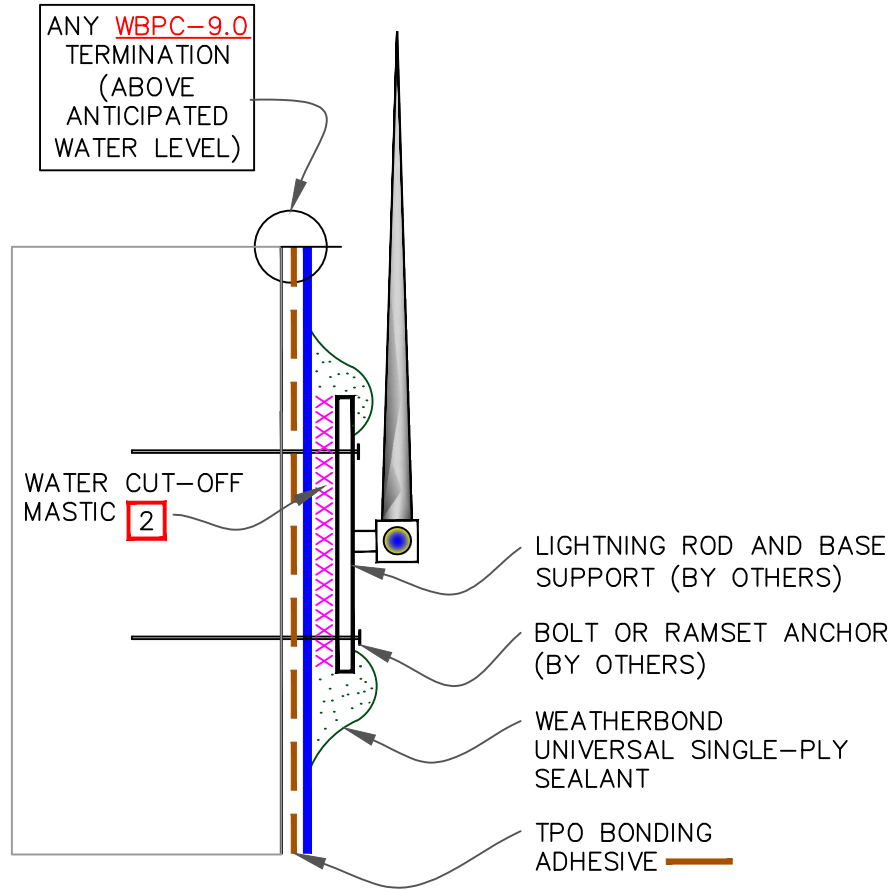



NOTES:

1. DETAIL MAY BE USED FOR ANY FASTENER PENETRATION (E.G., ACCESS LADDER, ANCHOR SUPPORT TO PARAPET).
2. WATER CUT-OFF MASTIC MUST BE UNDER CONSTANT COMPRESSION.
3. DETAIL UNACCEPTABLE FOR HORIZONTAL APPLICATION ON ROOF DECK.
4. COMPLY WITH ZONING ORDINANCE AND LOCAL CODES FOR MOUNTING A LIGHTNING SYSTEM.



LIGHTNING ROD AT PARAPET (VERTICAL ATTACHMENT)

-  TPO MEMBRANE
-  APPROVED SUBSTRATE
-  SEE NOTE

THERMOPLASTIC ROOFING SYSTEM

WBPC-20.1

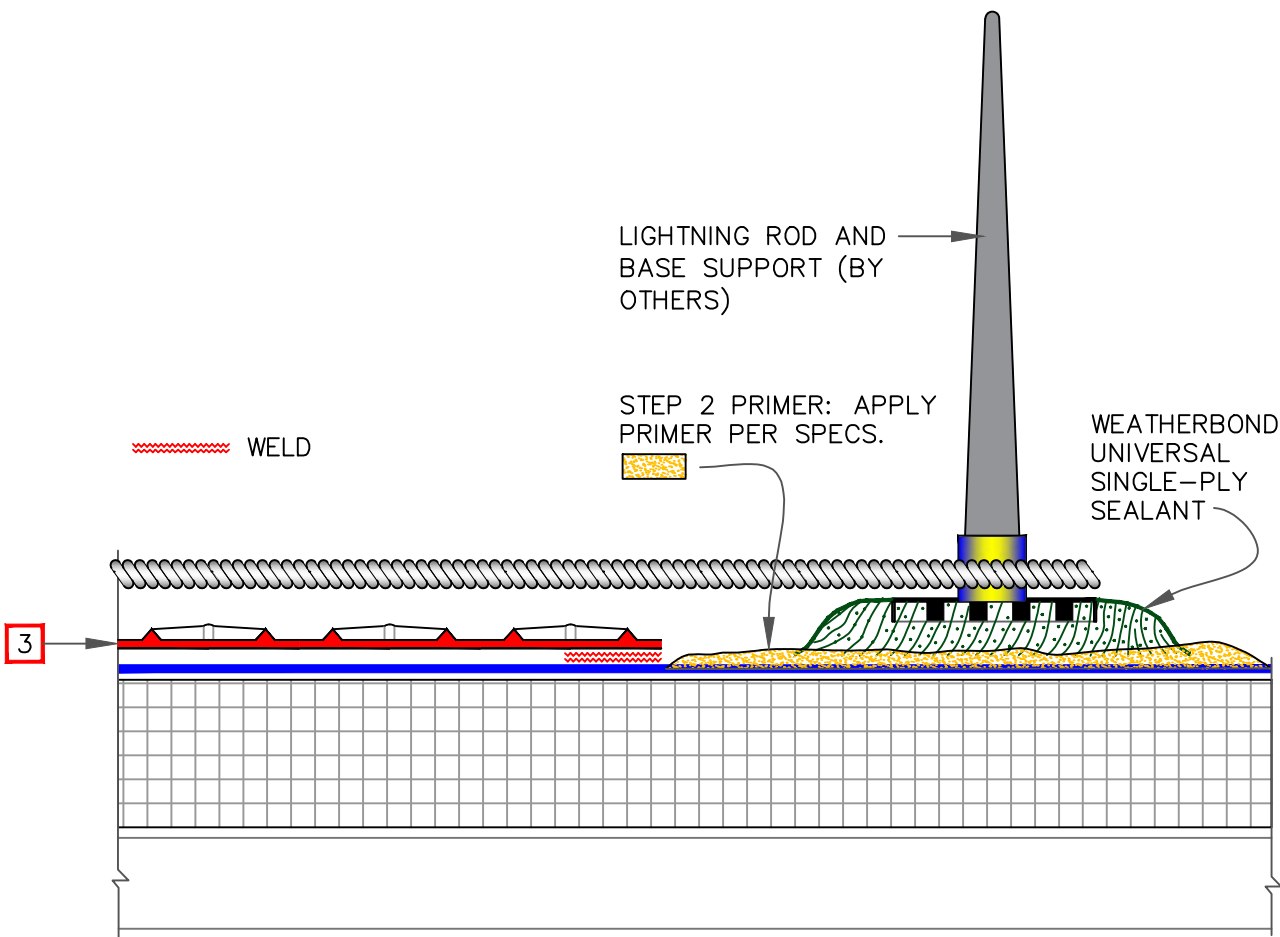

NOTES:

1. CLEAN EXPOSED MEMBRANE SURFACE WITH WEATHERED MEMBRANE CLEANER AND ALLOW TO DRY.
2. COMPLY WITH ZONING ORDNANCE AND LOCAL CODES FOR MOUNTING A LIGHTNING SYSTEM.
3. TO AVOID SURFACE ABRASION, PIECES OF WALK-WAY PADS SHOULD BE WELDED UNDERNEATH THE BRAIDED WIRES. ENSURE, WATER FLOW IS NOT RESTRICTED AND PROVIDE PROPER GAPS.



EXAMPLE: BRAIDED WIRE IN CERTAIN COUNTRIES



LIGHTNING ROD AT DECK LEVEL

- TPO MEMBRANE
- APPROVED SUBSTRATE
- 0 —● SEE NOTE

THERMOPLASTIC ROOFING SYSTEM

WBPC-20.2