

MEMBRANE SPLICE

END LAP SPLICE

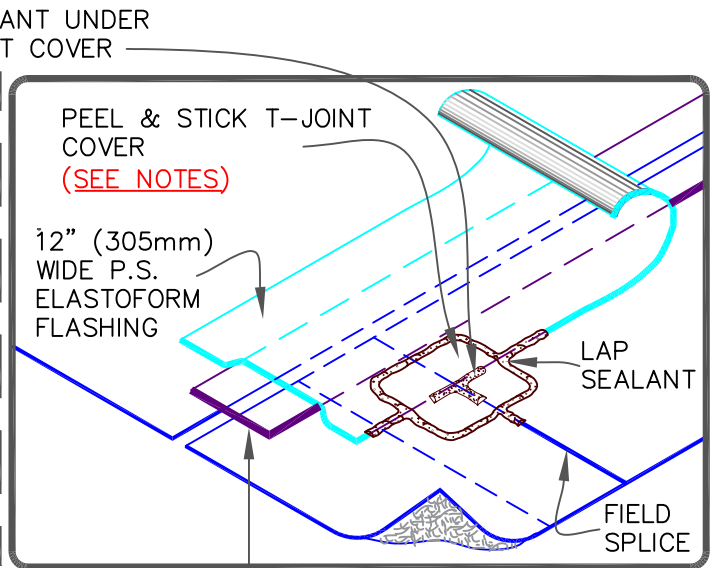
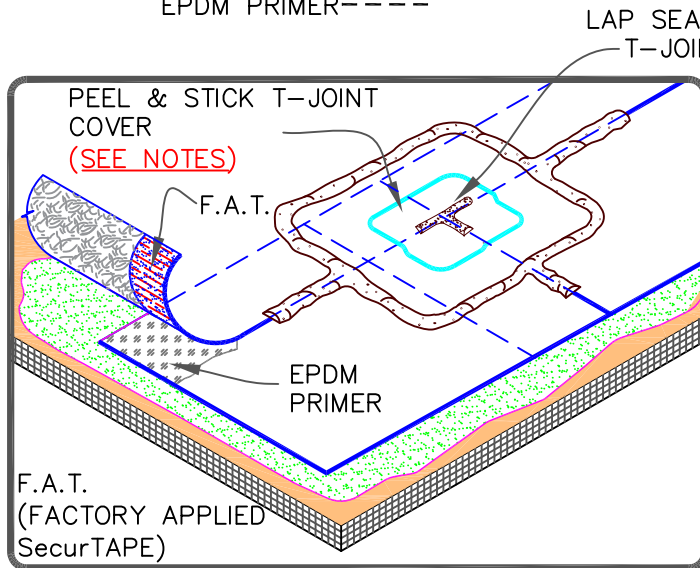
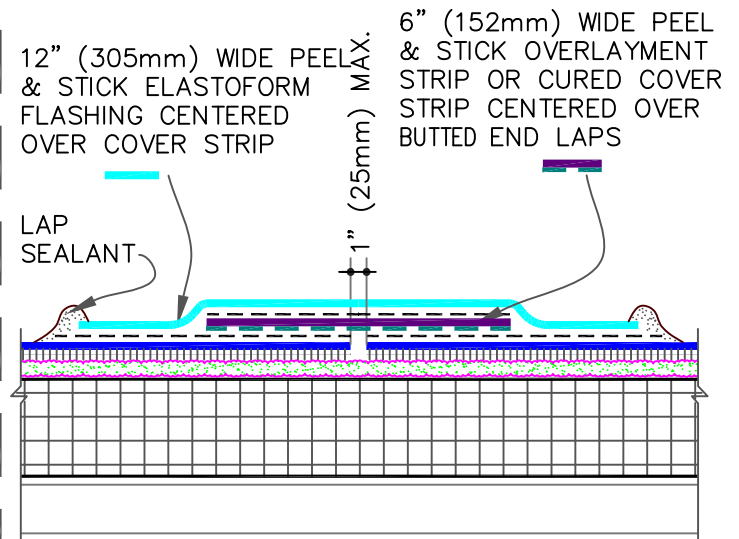
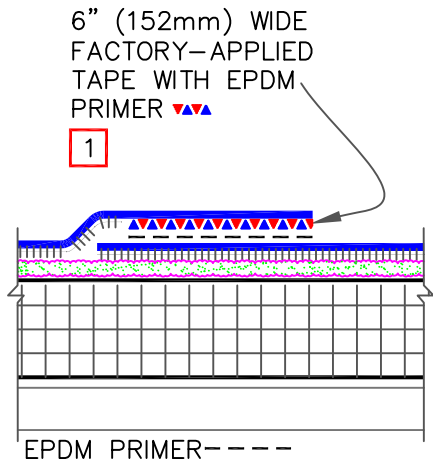

NOTES:

1. APPLY EPDM PRIMER TO MEMBRANE SURFACES PRIOR TO INSTALLING PEEL & STICK FLASHING AND/OR FACTORY APPLIED SecurTAPE.
2. APPLY LAP SEALANT ALONG THE EDGE OF THE MEMBRANE SPLICE (UNDER THE 6"x6" T-JOINT COVER) COVERING THE EXPOSED SPLICE TAPE 1/2" (13mm) IN EACH DIRECTION FROM THE SPLICE INTERSECTION.
3. ALL EPDM SPLICE INTERSECTIONS MUST BE OVERLAID WITH TWO LAYERS OF PEEL & STICK ELASTOFORM FLASHING. THE BOTTOM LAYER SHALL BE 6"x6" (152mm X 152mm) COVERED WITH A 12"x12" TOP LAYER (305mm X 305mm). BOTH LAYERS SHALL BE CENTERED OVER THE SPLICE INTERSECTION AND SEALED WITH CONTINUOUS LAP SEALANT, AS SHOWN.

6" (152mm) WIDE PEEL & STICK OVERLAYMENT STRIP OR CURED COVER STRIP CENTERED OVER BUTTED END LAPS