

EPDM PRIMER-----

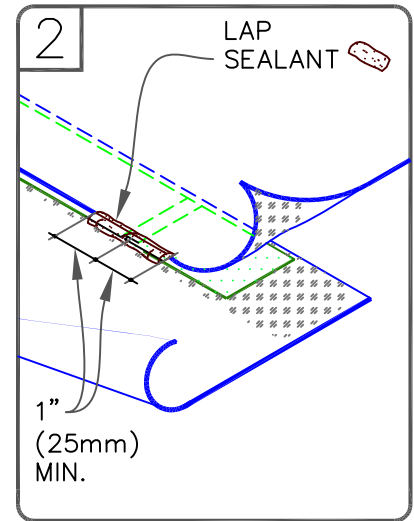

NOTES:

1. APPLY EPDM PRIMER TO THE MEMBRANE SURFACES PRIOR TO INSTALLING PEEL & STICK FLASHING.
2. LAP SEALANT IS REQUIRED ON CUT EDGES OF REINFORCED EPDM MEMBRANE.

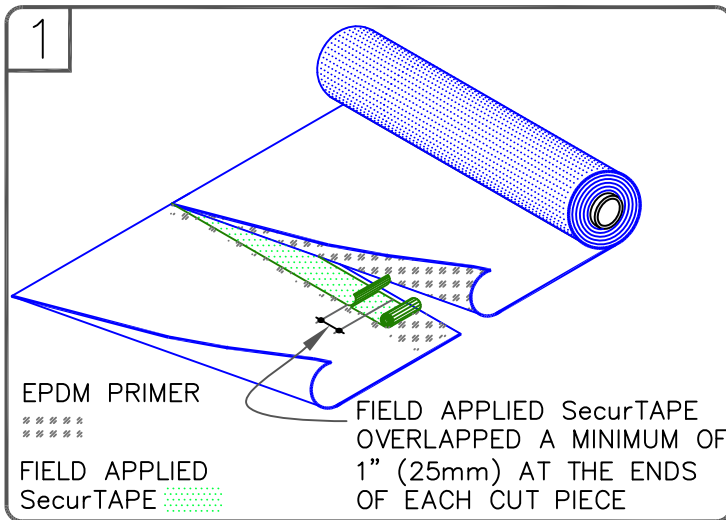
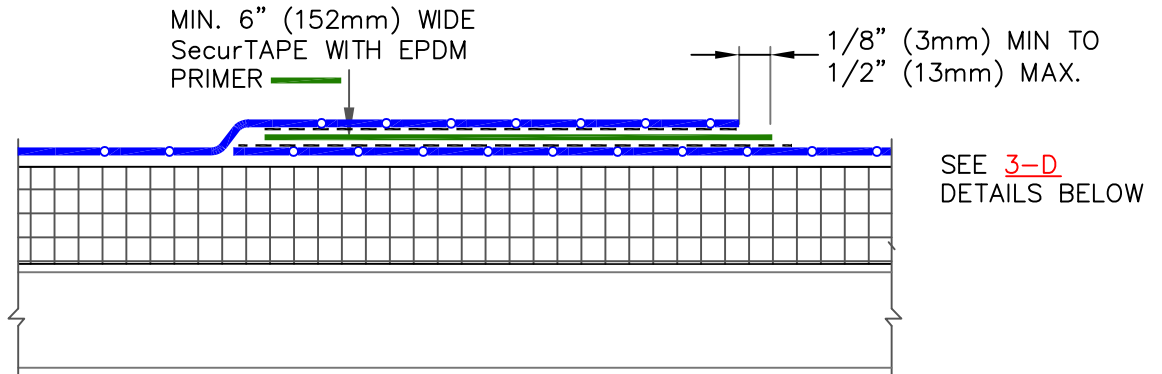
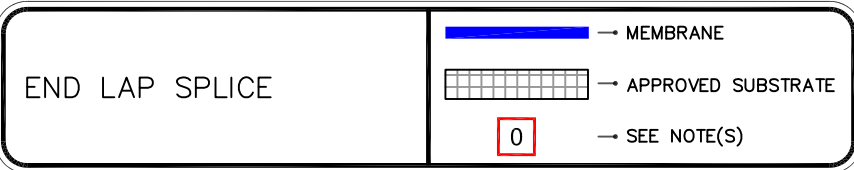

SPEC. SUPPLEMENT

MF-2.2