

INJECT VapAir Seal Flashing Foam PER SPECS & ALLOW TO SOLIDIFY. SHAVE PROTRUSIONS TO ACHIEVE SMOOTH SURFACE

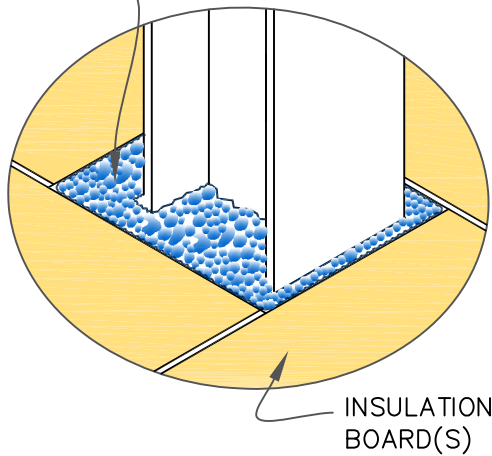

STEP 1

GRIND METAL WITH DIAMOND CUP GRINDING WHEEL

MEMBRANE SECURED WITH PLATES & FASTENERS PER SPECS

STEP 2



A

NOTE: ENSURE BODY OF PENETRATIONS & WELDS ARE COMPLETELY WATERPROOF.



B

DIAMOND CUP GRINDING WHEEL

STEP 3



C

USE SAND PAPER GRIT# 60 TO ABRAD THE MEMBRANE SURFACE.

STEP 4



D

REMOVE ALL GRINDING DUST, CLEAN METAL & MEMBRANE WITH CLEAN RAGS & MEMBRANE CLEANER.

STEP 5

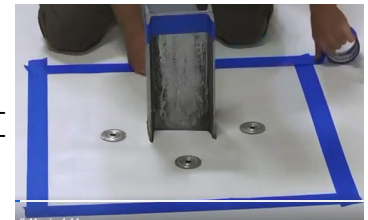

E

USE PAINTER'S TAPE AND TAPE OFF THE FLASHING AREA.

MEASURING, CUTTING & DRY FITTING TECHNIQUE

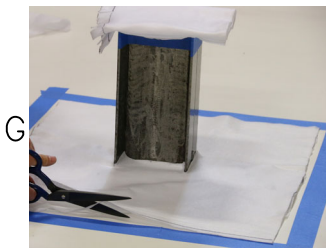
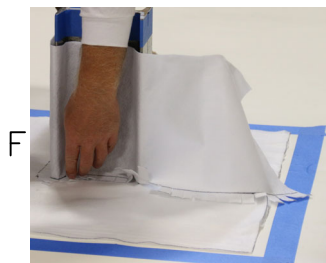

F

G

STEP 6

STEP 7

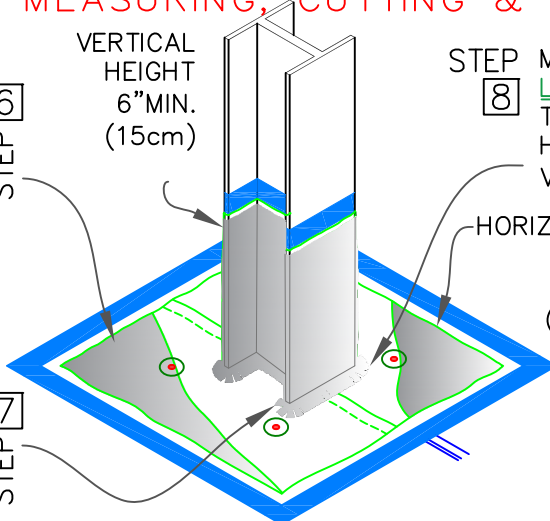

STEP 8 MAKE FINGER CUTS 2" (5cm) LONG IN LIQISEAL Flashing Fleece AS SHOWN. THE FINGERS WILL REST ON THE HORIZONTAL SURFACE. SEE ENLARGED VIEW "I" ON PAGE 2 OF 2.

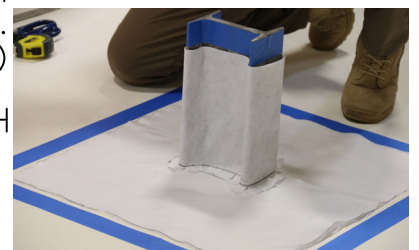

H