

NOTES:

1. FASCIA HORIZONTAL FLANGE MUST BE TOTALLY COVERED MINIMUM 2" (5cm) BEYOND THE NAIL.
2. REFER TO [MR Z1.1](#) & [MR Z1.2](#) AT THE END OF THIS SECTION.

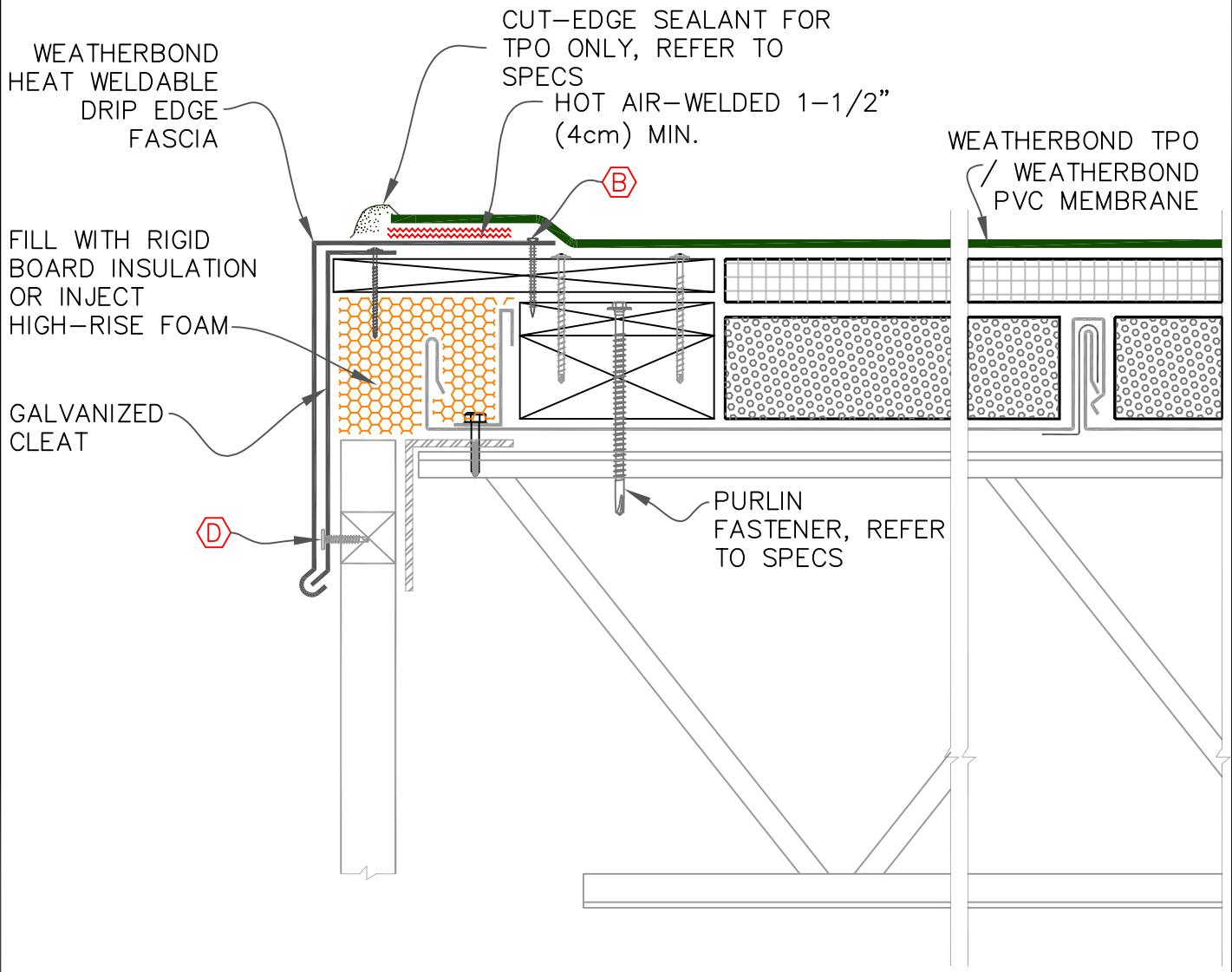
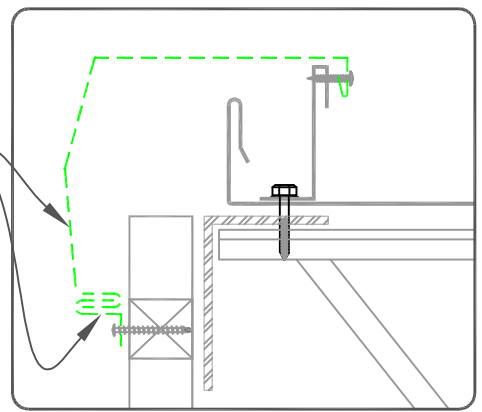

A HPW FASTENERS @ 12" (30cm) O.C. OR RING-SHANK NAILS @ 4" (10cm) O.C. & STAGGERED 3/4" (2cm) O.C.

D FASTENERS TO MATCH EXISTING @ 6" O.C., MAX., EXPOSED 3/4" (2cm) MIN. BEYOND EXISTING SUBSTRATE

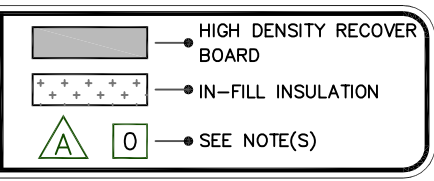
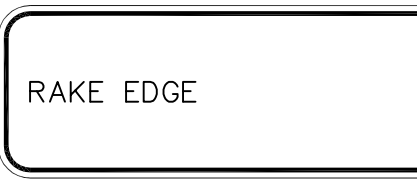

METAL RETROFIT
MR | T1.10