

NOTES:

1. TEMPERATURE OF PIPE MUST NOT EXCEED 160° F (71° C).
2. WHEN USING TPO MOLDED SEALANT POCKET, TPO PRIMER MUST BE APPLIED TO ALL INSIDE SURFACES AND PENETRATIONS PRIOR TO FILLING WITH SEALANT. WHEN USING PVC MOLDED SEALANT POCKET, CLEAN THE POCKET WITH PVC CLEANER, APPLY TPO PRIMER TO PENETRATION(S) ONLY.
3. FILL POCKET COMPLETELY WITH WHITE ONE-PART POURABLE SEALER UNTIL RIM IS COVERED WITH SEALANT; ENSURE ALL VOIDS ARE FILLED.
4. ON MECHANICALLY-ATTACHED SYSTEMS, INSTALL A MINIMUM OF 4 FASTENING PLATES AROUND SEALANT POCKETS WITH A DIAMETER UP TO 6" (15cm). ADDITIONAL FASTENING PLATES WILL BE REQUIRED FOR SEALANT POCKETS GREATER THAN 6" IN DIAMETER AND SHALL BE SPACED 12" (30cm) ON CENTER MAXIMUM.
5. REFER TO WEATHERBOND SPECIFICATIONS FOR PROPER FASTENERS AND PLATES.
6. APPROXIMATELY 1/8" (0.5cm) DIAMETER BEAD OF CUT-EDGE SEALANT IS REQUIRED ON CUT EDGES OF WEATHERBOND REINFORCED TPO MEMBRANE.

PLACE MOLDED WEATHERBOND SEALANT POCKET AROUND PENETRATION AND OVERLAP THE TWO SECTIONS

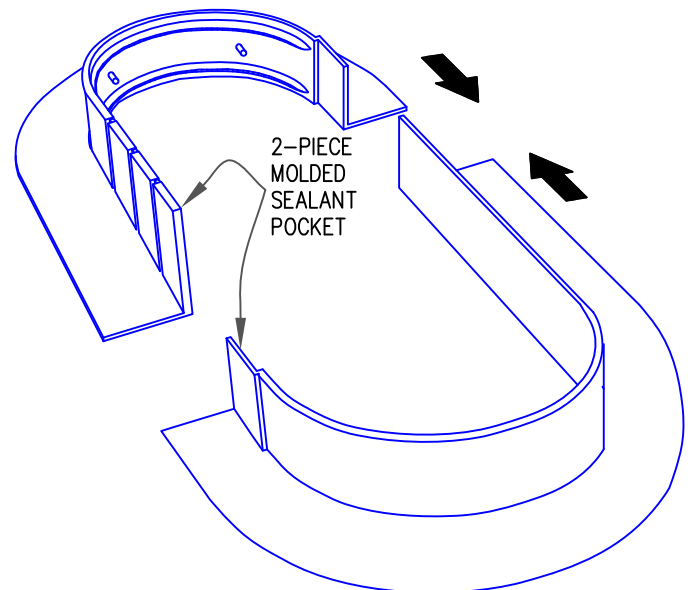

REFER TO PRODUCT DATA SHEET FOR STEP-BY-STEP INSTALLATION PROCEDURES



MOLDED SEALANT POCKET

	WEATHERBOND THERMOPLASTIC REINFORCED MEMBRANE
	APPROVED SUBSTRATE
	SEE NOTE

THERMOPLASTIC ROOFING SYSTEM

WBPC-16.1