

NOTES:

1. FOUR (4) CURB WRAP CORNERS WILL COMPLETELY FLASH A MAXIMUM CURB SIZE OF 3'X3' (91cm X 91cm). FOR LARGER CURBS USE THE TPO CURB WRAP CORNERS IN CONJUNCTION WITH ADDITIONAL SECTIONS OF WEATHERBOND TPO MEMBRANE.
2. WHEN MECHANICAL FASTENERS ARE USED TO PENETRATE THE METAL COUNTER-FLASHING, USE EPDM WASHERS, APPLY WATER CUT-OFF MASTIC UNDER THE COUNTER-FLASHING OR CAULK THE FASTENER HEADS.
3. APPROXIMATELY 1/8" (0.5cm) BEAD OF CUT-EDGE SEALANT IS REQUIRED ON THE CUT EDGES OF THE TPO FIELD WRAP CORNER.
4. REFER TO WEATHERBOND SPECIFICATIONS FOR ACCEPTABLE WEATHERBOND FASTENERS AND PLATES.
5. CUSTOM SIZES ARE AVAILABLE FOR CURB FLASHING HEIGHTS GREATER THAN 12" (30cm).
6. APPLICABLE BONDING ADHESIVE FOR PVC OR TPO. IN CASE OF TPO CAV-GRIP III ADHESIVE MAY ALSO BE USED ON VERTICAL PORTION.

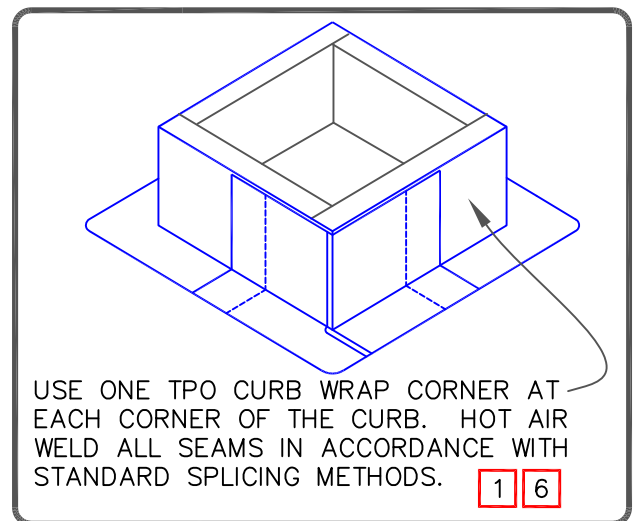

PRE-FABRICATED TPO CURB OR PVC WRAP CORNER

THERMOPLASTIC ROOFING SYSTEM

WBPC-5.3