

DIMENSIONS	cm	
(A) 2"	5	MIN.
(B) 3"	7.5	APPROX.

NOTES:

1. CONSULT THE RESPECTIVE MANUFACTURER OF THE SELF-FLASHING METAL CURB FOR PROPER SECUREMENT.
2. WATER CUT-OFF MASTIC MUST BE HELD UNDER CONSTANT COMPRESSION.
3. USE [DETAIL WBRC-15.6](#) TO ACHIEVE SUFFICIENT COVERAGE OF METAL FLANGE AT CORNERS.
4. IF THE VERTICAL SPLICE ON THE CURB FLASHING IS NOT LOCATED AT THE CORNER USE [DETAIL WBRC-2.3](#) FOR EPDM MEMBRANE SPLICES AT ANGLE CHANGES.

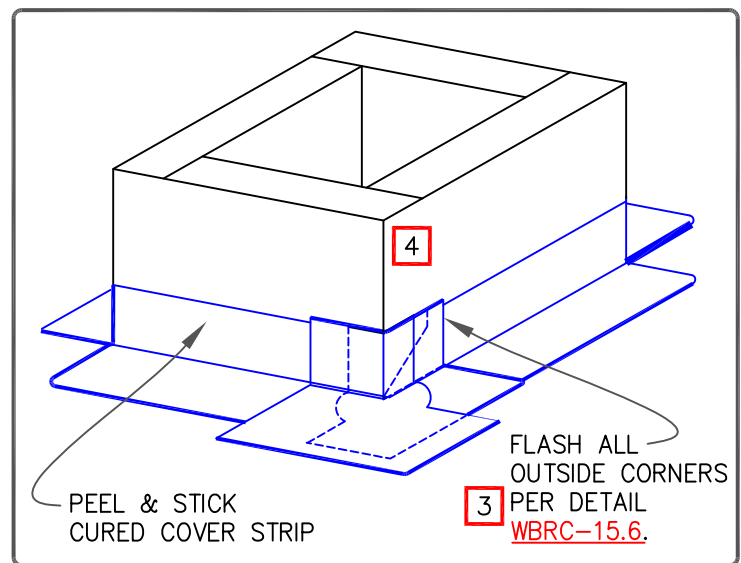

NEW SELF-FLASHING METAL CURB

- EPDM MEMBRANE
- APPROVED SUBSTRATE
- SEE NOTE

EPDM ROOFING SYSTEM

WBRC-5.4