

NOTES:

1. REMOVE ALL LEAD AND OTHER FLASHING BEFORE INSTALLING PIPE SEAL.
2. TEMPERATURE OF PIPE MUST NOT EXCEED 180°F (82°C).
3. PRE-MOLDED PIPE SEAL MUST HAVE INTACT RIB AT THE TOP EDGE REGARDLESS OF PIPE DIAMETER.
4. INSTALL A MIN. OF 4 FASTENERS FOR PIPES WITH OUTSIDE DIAMETER <6" (15cm). SEE DETAIL [WBRMA-8.4](#) FOR WIDER PIPES.
5. DECK FLANGES OF THE PEEL & STICK PIPE SEAL SHALL NOT BE OVERLAPPED, CUT OR APPLIED OVER ANY ANGLE CHANGE.

DIMENSIONS	cm	
(A)	1/2"	1.5
(B)	6"	15 TO 30
(C)	2"	5
(D)	1/2"	1.5 TO 6"

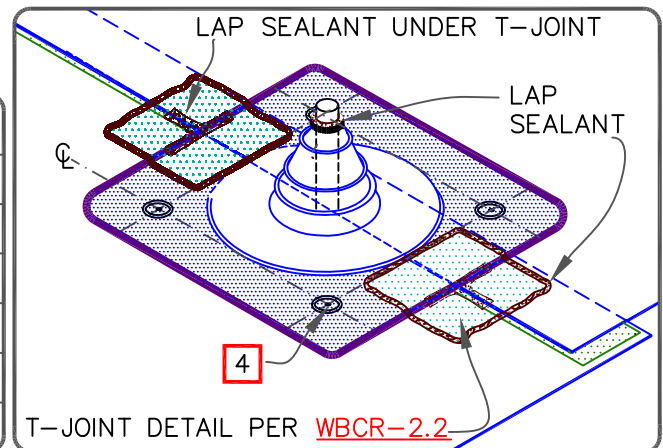

PEEL & STICK PIPE SEAL WITH 20" PEEL & STICK CURED FLASHING

- REINFORCED EPDM—UNLESS NOTED OTHERWISE
- APPROVED SUBSTRATE
- SEE NOTE

MECHANICALLY ATTACHED EPDM  
WBRMA-8.3